

SA's Leading Past Year

Exam Paper Portal

STUDY

You have Downloaded, yet Another Great Resource to assist you with your Studies 😊

Thank You for Supporting SA Exam Papers

Your Leading Past Year Exam Paper Resource Portal

Visit us @ [www.saexampapers.co.za](http://www.saexampapers.co.za)



SA EXAM  
PAPERS



# basic education

Department:  
Basic Education  
**REPUBLIC OF SOUTH AFRICA**

**NATIONAL  
SENIOR CERTIFICATE**

**GRADE 12**

**LIFE SCIENCES P1**

**NOVEMBER 2018**

**MARKS: 150**

**TIME: 2½ hours**

**This question paper consists of 19 pages.**

**INSTRUCTIONS AND INFORMATION**

Read the following instructions carefully before answering the questions.

1. Answer ALL the questions.
2. Write ALL the answers in the ANSWER BOOK.
3. Start the answers to EACH question at the top of a NEW page.
4. Number the answers correctly according to the numbering system used in this question paper.
5. Present your answers according to the instructions of each question.
6. Do ALL drawings in pencil and label them in blue or black ink.
7. Draw diagrams, tables or flow charts only when asked to do so.
8. The diagrams in this question paper are NOT necessarily drawn to scale.
9. Do NOT use graph paper.
10. You must use a non-programmable calculator, protractor and a compass, where necessary.
11. Write neatly and legibly.

**SECTION A****QUESTION 1**

1.1 Various options are provided as possible answers to the following questions. Choose the answer and write only the letter (A to D) next to the question numbers (1.1.1 to 1.1.10) in the ANSWER BOOK, e.g. 1.1.11 D.

1.1.1 Which of the following are hormones that directly stimulate the development of the endometrium?

- A FSH and LH
- B Progesterone and oestrogen
- C FSH and progesterone
- D LH and oestrogen

1.1.2 A function of the iris of the eye is to ...

- A refract light to form a clear image.
- B control the amount of light that enters the eye.
- C convert the light stimuli into impulses.
- D prevent reflection of light within the eye.

1.1.3 Diagram **A** and diagram **B** below represent the same part of the same human eye under different conditions.

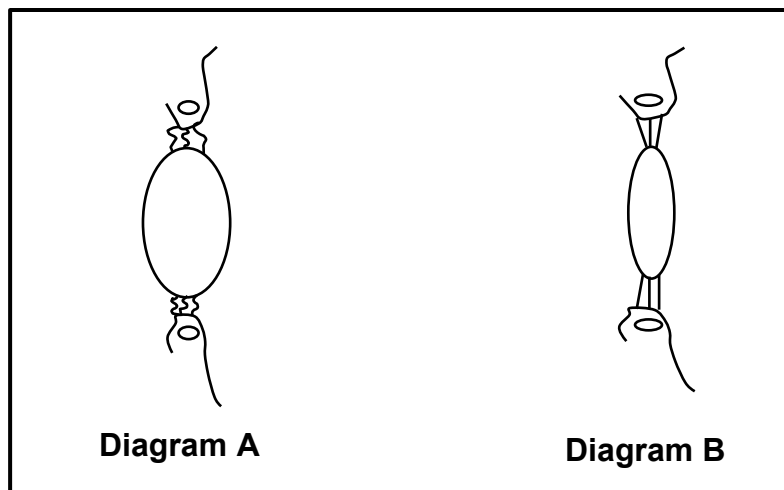

Which diagram, with a corresponding reason, represents a person looking at an object 10 metres away?

- A Diagram **A** because the suspensory ligaments are taut/tight and the lens is less convex
- B Diagram **A** because the lens is more convex and the suspensory ligaments are slack
- C Diagram **B** because the lens is more convex and the suspensory ligaments are slack
- D Diagram **B** because the suspensory ligaments are taut/tight and the lens is less convex

- 1.1.4 Which of the following are plant growth hormones?
- A Prolactin and abscisic acid
  - B Abscisic acid and glucagon
  - C Gibberellins and abscisic acid
  - D ADH and gibberellins
- 1.1.5 A function of the placenta is to ...
- A transport waste from mother to foetus.
  - B form the chorion.
  - C secrete progesterone.
  - D secrete the fluid that surrounds the foetus.
- 1.1.6 Which ONE of the following will lead to a decrease in water quality?
- A Eutrophication
  - B Use of aquifers
  - C Maintaining wetlands
  - D Drought
- 1.1.7 A chemical used in laboratories prevents spindle fibres from forming in cells undergoing meiosis. As a result meiosis cannot start on the completion of interphase.
- In an investigation, this chemical was added to cells in the anthers of the flowers of rice plants. Each cell in the anther has 24 chromosomes.
- What is the expected number of chromosomes in each cell at the end of the investigation?
- A 12 replicated chromosomes
  - B 24 replicated chromosomes
  - C 24 unreplicated chromosomes
  - D 48 unreplicated chromosomes

1.1.8 A scientist designed an investigation to test the following:

Eating more salt will decrease urine production and increase water consumption.

The table below shows the results of the investigation.

<b>AMOUNT OF SALT CONSUMED (g)</b>	<b>VOLUME OF URINE PRODUCED (mℓ)</b>	<b>AMOUNT OF WATER CONSUMED (mℓ)</b>
3	1 803	2 800
6	1 800	2 700
9	1 805	2 600
12	1 802	2 500
15	1 801	2 400

A possible conclusion from the results above is that eating more salt ...

- A decreases urine production and increases the amount of water consumed.
- B increases urine production and decreases the amount of water consumed.
- C has little effect on urine production and decreases the amount of water consumed.
- D has little effect on urine production and increases the amount of water consumed.

1.1.9 An advantage of internal fertilisation is that ...

- A sperm and ova are protected within the female's body.
- B there is better parental care.
- C more gametes will be produced.
- D the foetus receives food directly from the mother.

- 1.1.10 The graphs below represent the results of an investigation to determine if there is a possible relationship between temperature and the dissolved oxygen content of water and fish size.

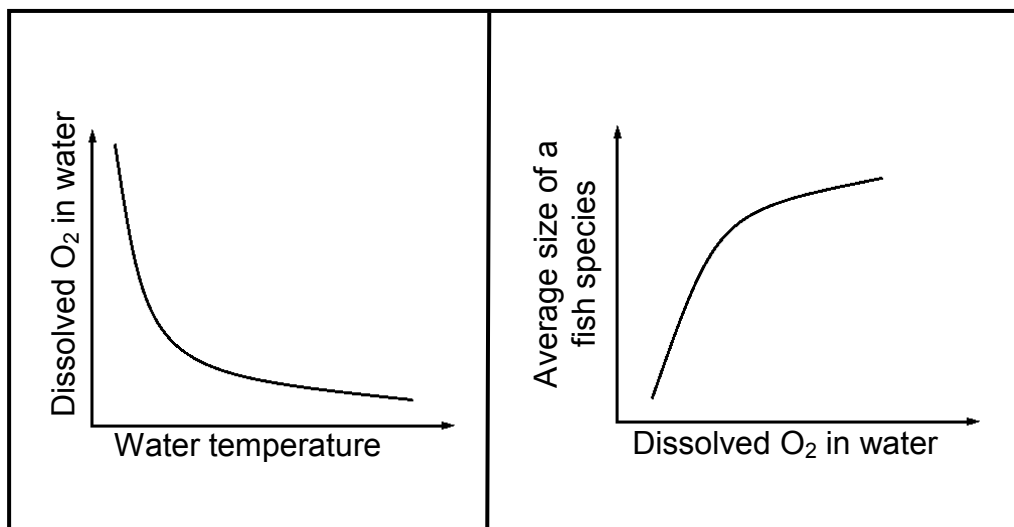

Which ONE of the following is a possible interpretation based on information from both graphs?

- A There will be no relationship between water temperature and fish size.
- B As the temperature of the water increases, the amount of dissolved oxygen will increase.
- C The average size of the fish will decrease as the temperature of the water increases.
- D The amount of dissolved oxygen in the water will not influence fish size.

(10 x 2) (20)

1.2 Give the correct **biological term** for EACH of the following descriptions. Write only the term next to the question numbers (1.2.1 to 1.2.10) in the ANSWER BOOK.

- 1.2.1 The type of egg produced by reptiles that has extra-embryonic membranes
- 1.2.2 The type of development in birds where the hatchlings' eyes are open and their bodies are covered with down feathers
- 1.2.3 The part of the brain that receives impulses from the maculae
- 1.2.4 The dark pigmented layer of the eye
- 1.2.5 The structure that connects the left and right hemispheres of the brain
- 1.2.6 The part of the brain that controls body temperature
- 1.2.7 The gas in the blood which, when increased, causes an increase in the breathing rate
- 1.2.8 Plant growth responses to external stimuli
- 1.2.9 A substance containing plant hormones used to kill unwanted plants
- 1.2.10 The illegal hunting and killing of animals

**(10)**

1.3 Indicate whether each of the descriptions in COLUMN I apply to **A ONLY**, **B ONLY**, **BOTH A AND B** or **NONE** of the items in COLUMN II. Write **A only**, **B only**, **both A and B** or **none** next to the question numbers (1.3.1 to 1.3.3) in the ANSWER BOOK.

COLUMN I	COLUMN II
1.3.1 Doubling of DNA	A: Prophase I B: Prophase II
1.3.2 Condition affecting the cornea of the eye	A: Astigmatism B: Cataract
1.3.3 Nutrition provided by the egg	A: Ovipary B: Ovovivipary

(3 x 2)

**(6)**

- 1.4 The diagram below represents a sequence of events that may take place inside the human female reproductive system.

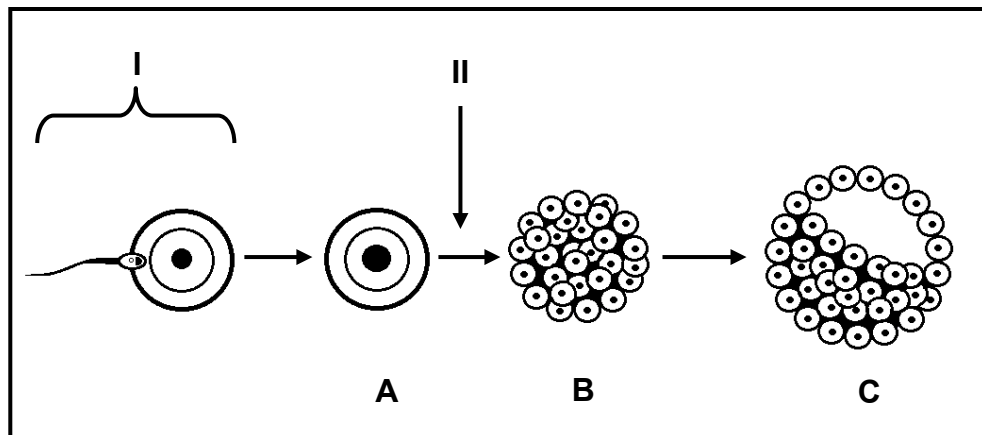

- 1.4.1 Identify the process taking place at **I** in the diagram above. (1)
- 1.4.2 State the type of cell division that takes place at **II** in the diagram above. (1)
- 1.4.3 Name TWO functional extra-embryonic membranes that are produced by structure **C**. (2)
- 1.4.4 Identify the stage of development indicated by:
- (a) **A** (1)
- (b) **B** (1)
- (c) **C** (1)
- 1.4.5 Name the part of the female reproductive system where the events in the diagram above usually take place. (1)
- 1.4.6 Give the chromosome number of the cell at **A** if this cell is going to develop into a child with Down syndrome. (1)
- (9)**

1.5 The diagram below shows the hormones involved in the homeostatic control of metabolism in the human body. **X** is a gland found around the larynx in the neck.

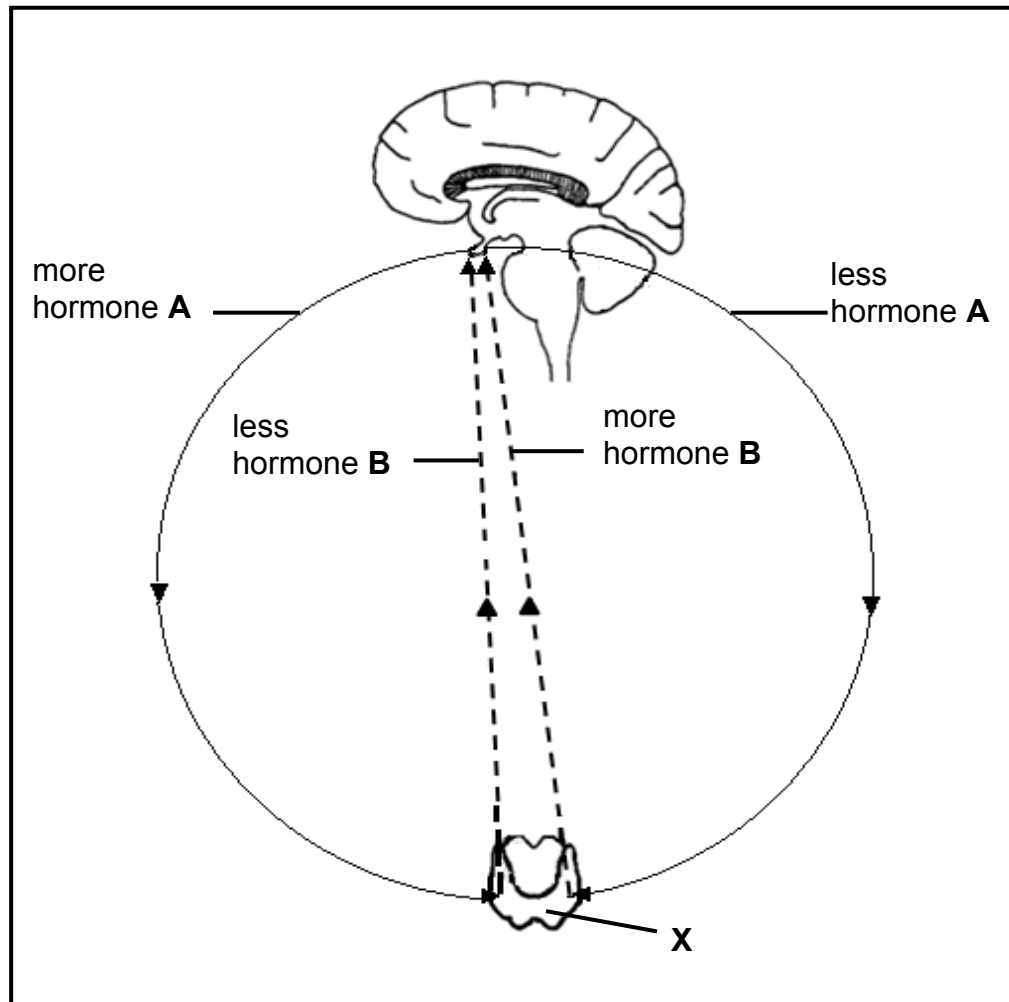

1.5.1 Identify EACH of the following:

- (a) The gland that secretes hormone **A** (1)
- (b) Hormone **B** (1)

1.5.2 Name the mechanism in the diagram that regulates the level of hormone **B**. (1)

1.5.3 Half of gland **X** was surgically removed in a person.

State TWO possible effects that this would have on the secretion of the hormones referred to in the diagram above. (2)  
(5)

**TOTAL SECTION A: 50**

**SECTION B**

**QUESTION 2**

2.1 The diagrams below represent various phases of meiosis.

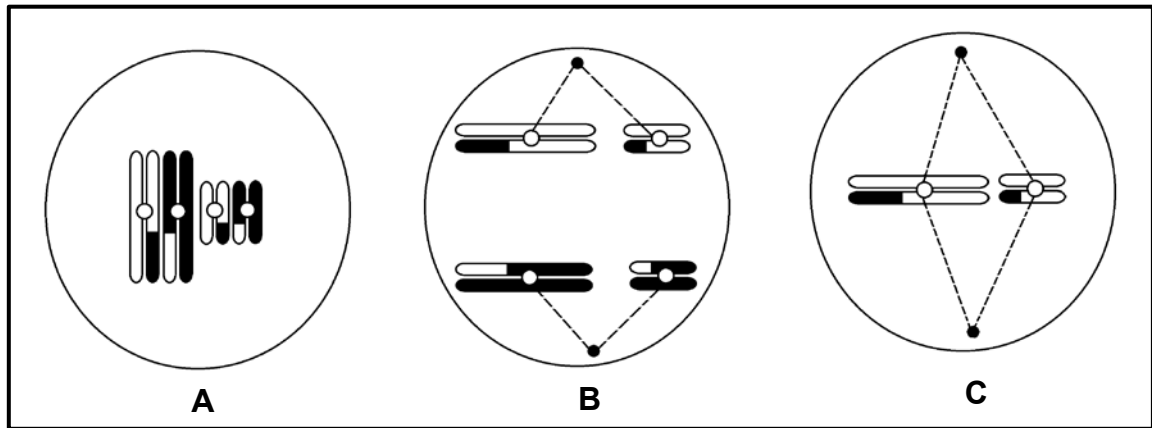

2.1.1 Identify the phase of meiosis in diagram:

(a) **A** (1)

(b) **B** (1)

2.1.2 Draw a labelled diagram to show the cells that will be formed at the end of meiosis from the cell in diagram **C**.

(5)  
(7)

- 2.2 Read the extract below about a medical condition in male babies called cryptorchidism.

Cryptorchidism occurs in new-borns when one or both of the testes do not descend into the scrotal sac at birth, but remains inside the abdominal cavity.

Cryptorchidism occurs in approximately 3–5% of full-term male infants while approximately one third of premature male babies are born with this condition.

If the testes do not descend naturally by the age of one, treatment is needed. Treatment may involve administering testosterone, but the most common treatment is surgery.

If cryptorchidism is not resolved, it may lead to infertility when both the testes do not descend and an increased risk of testicular cancer by the age of 30 to 40 years.

- 2.2.1 State ONE function of testosterone not mentioned in the extract above. (1)
- 2.2.2 According to the extract, state TWO ways in which cryptorchidism is treated. (2)
- 2.2.3 What percentage of premature male babies are born with cryptorchidism? (1)
- 2.2.4 From the extract, give ONE reason, other than infertility, why cryptorchidism needs to be treated if the condition is not resolved naturally. (1)
- 2.2.5 Explain why undescended testes may lead to infertility in young males. (2)
- (7)

2.3 Some women take longer to fall pregnant compared to others. A woman with a normal, fertile male partner, who takes longer than 12 months to fall pregnant, is said to be subfertile.

An investigation was conducted to determine the effect of BMI (body mass index) and smoking on subfertility.

BMI is calculated as follows: 
$$BMI = \frac{\text{Body mass (kg)}}{(\text{Height in metres})^2}$$

A total of 2 587 women between the ages of 20 and 30 participated in the investigation. All of the women were at least 20 weeks pregnant, had planned to fall pregnant and conceived naturally.

The following information was obtained from each woman:

- Height and mass
- Time taken to fall pregnant (in months)
- Smoking habits

Of the total number of women who participated, 1 510 were subfertile.

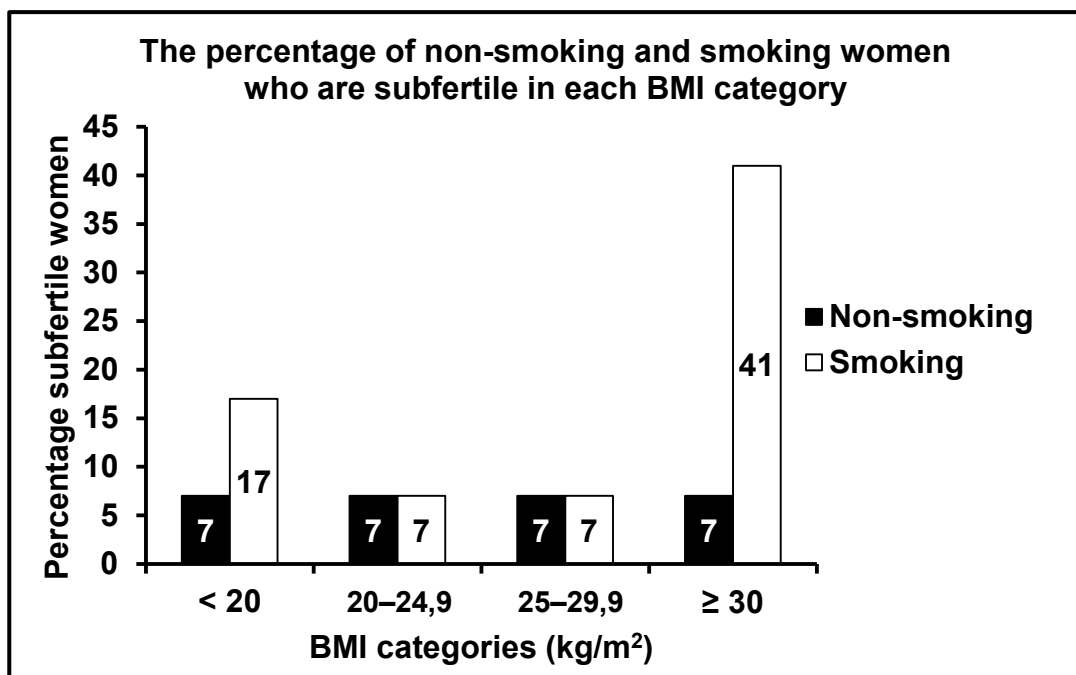

2.3.1 Give ONE reason why the women were asked for their height and mass. (1)

2.3.2 Determine how many of the participants were subfertile smokers with a BMI ≥30. Show ALL calculations. (3)

- 2.3.3 Suggest why only women with planned pregnancies were included in the investigation. (2)
- 2.3.4 State ONE factor that was kept constant in this investigation. (1)
- 2.3.5 Based on the information in the graph on page 12, what advice should be given to women who want to increase their chances of falling pregnant? (2)
- 2.3.6 The investigation was carried out in another country and the results below were obtained.

BMI (kg/m <sup>2</sup> )	% SUBFERTILE WOMEN	
	Non- smoking	Smoking
<20	7,2	18
20–24,9	7,4	7,3
25–29,9	7,4	7,3
≥30	7,4	38

Explain why the results of the original investigation can be considered to be reliable. (2)  
(11)

2.4 Study the diagram below.

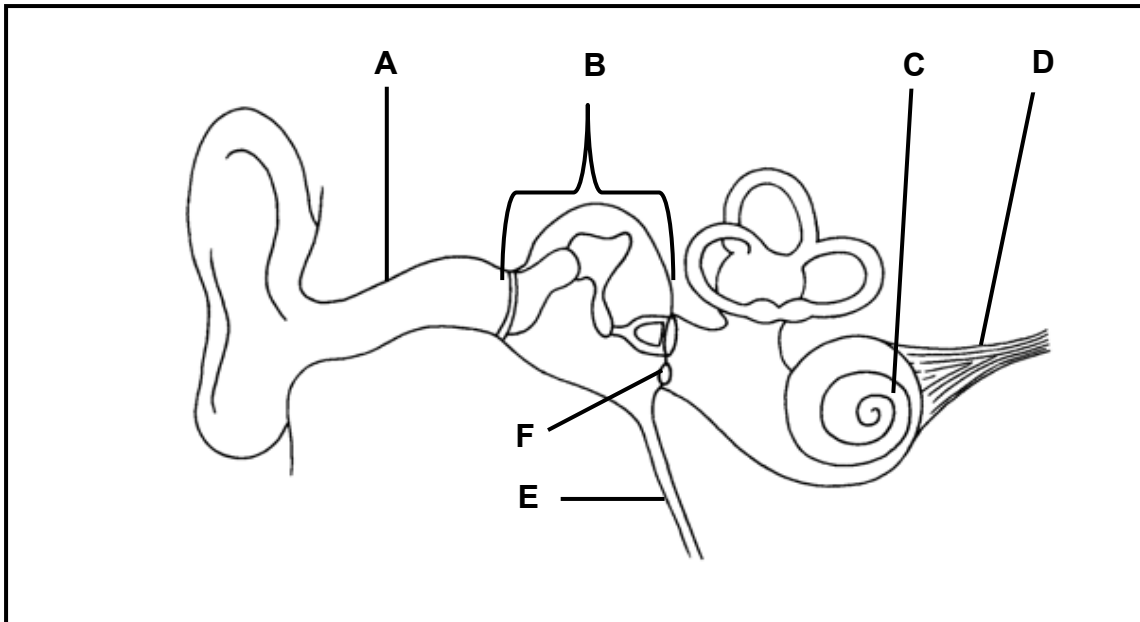

2.4.1 Give ONE function of part:

- (a) **A** (1)
- (b) **E** (1)
- (c) **F** (1)

2.4.2 Write down only the LETTER of the part where sound is transmitted in the form of:

- (a) A pressure wave in a liquid (1)
- (b) An electrical impulse (1)

2.4.3 Explain the effect if the receptors in region **C** are damaged. (3)

2.4.4 Describe how the parts of the middle ear, including the membranes, assist with amplifying sounds. (3)

2.4.5 Describe the role of the semi-circular canals in maintaining balance. (4)

**(15)**  
**[40]**

**QUESTION 3**

- 3.1 The diagrams below represent the growth responses of two different plant organs to external stimuli.

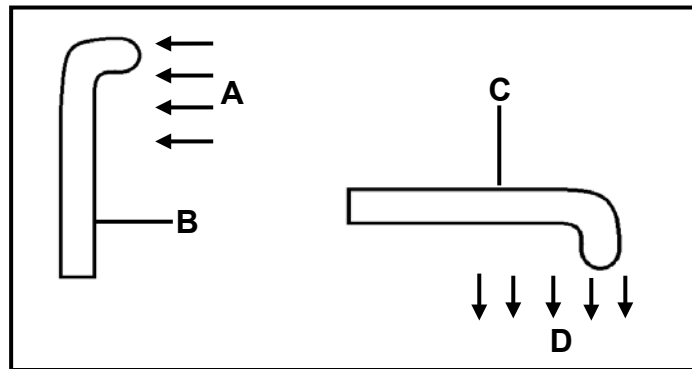

- 3.1.1 Name the group of plant hormones that is responsible for the growth responses observed in the diagrams. (1)
- 3.1.2 Name the external stimulus at:
- (a) **A** (1)
- (b) **D** (1)
- 3.1.3 Give ONE observable reason why plant organ **B** is a stem. (1)
- 3.1.4 Explain the growth response observed in plant organ **C**. (3)
- (7)

3.2 The diagram below represents two possible pathways, **A** and **B**, which a nerve impulse may follow in the human body.

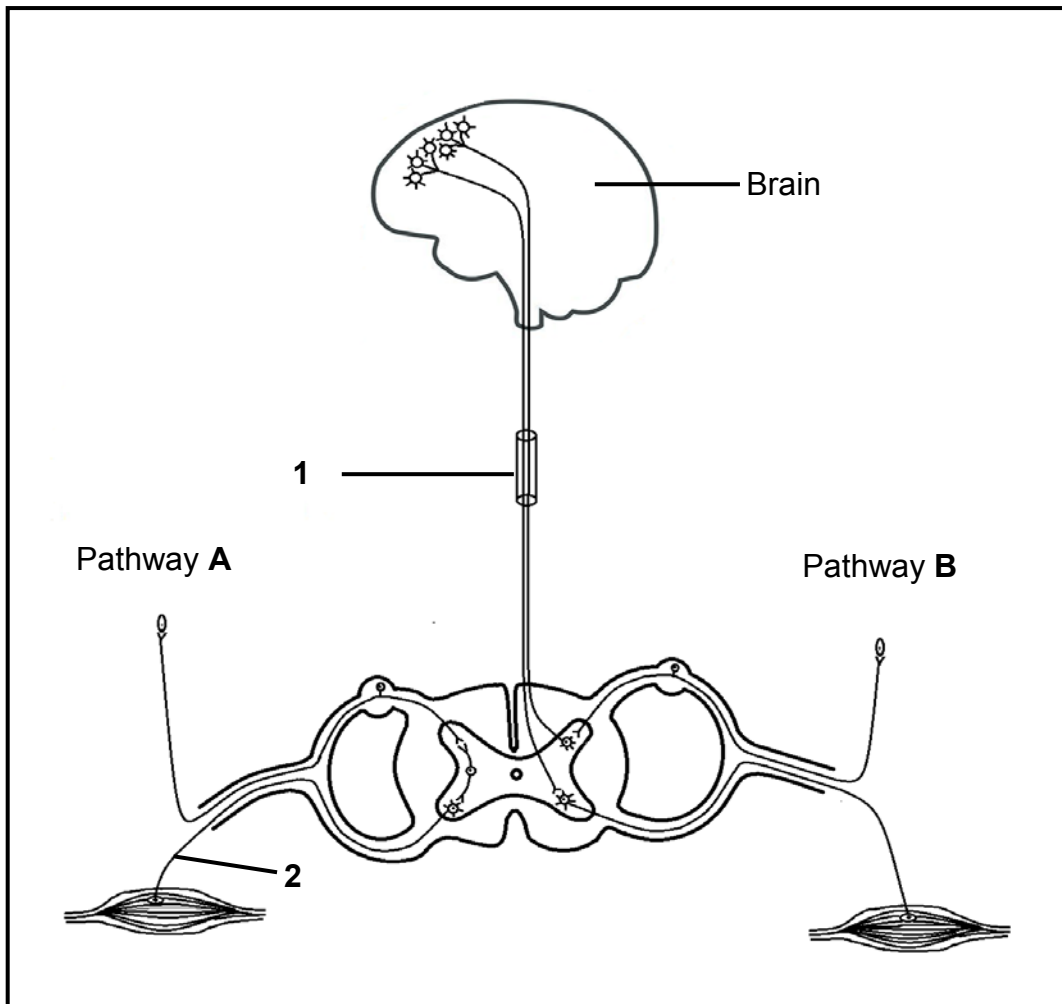

- 3.2.1 Which pathway, **A** or **B**, represents a reflex arc? (1)
  - 3.2.2 Give a visible reason in the diagram for your answer to QUESTION 3.2.1. (1)
  - 3.2.3 Describe the importance of a reflex action in the human body. (3)
  - 3.2.4 Identify the part of the nervous system represented by **1**. (1)
  - 3.2.5 Explain ONE way in which the myelin sheath is important in the functioning of neurons. (2)
  - 3.2.6 Describe how the person would be affected if the axon of neuron **2** was cut. (2)
  - 3.2.7 Describe pathway **B**. (6)
- (16)**

3.3 The graphs below show the effects of eating many small meals and eating fewer large meals on blood glucose and insulin concentrations in a normal person.

The arrows on the graphs below indicate when meals were eaten. The normal blood glucose concentration is 100 mg/dl.

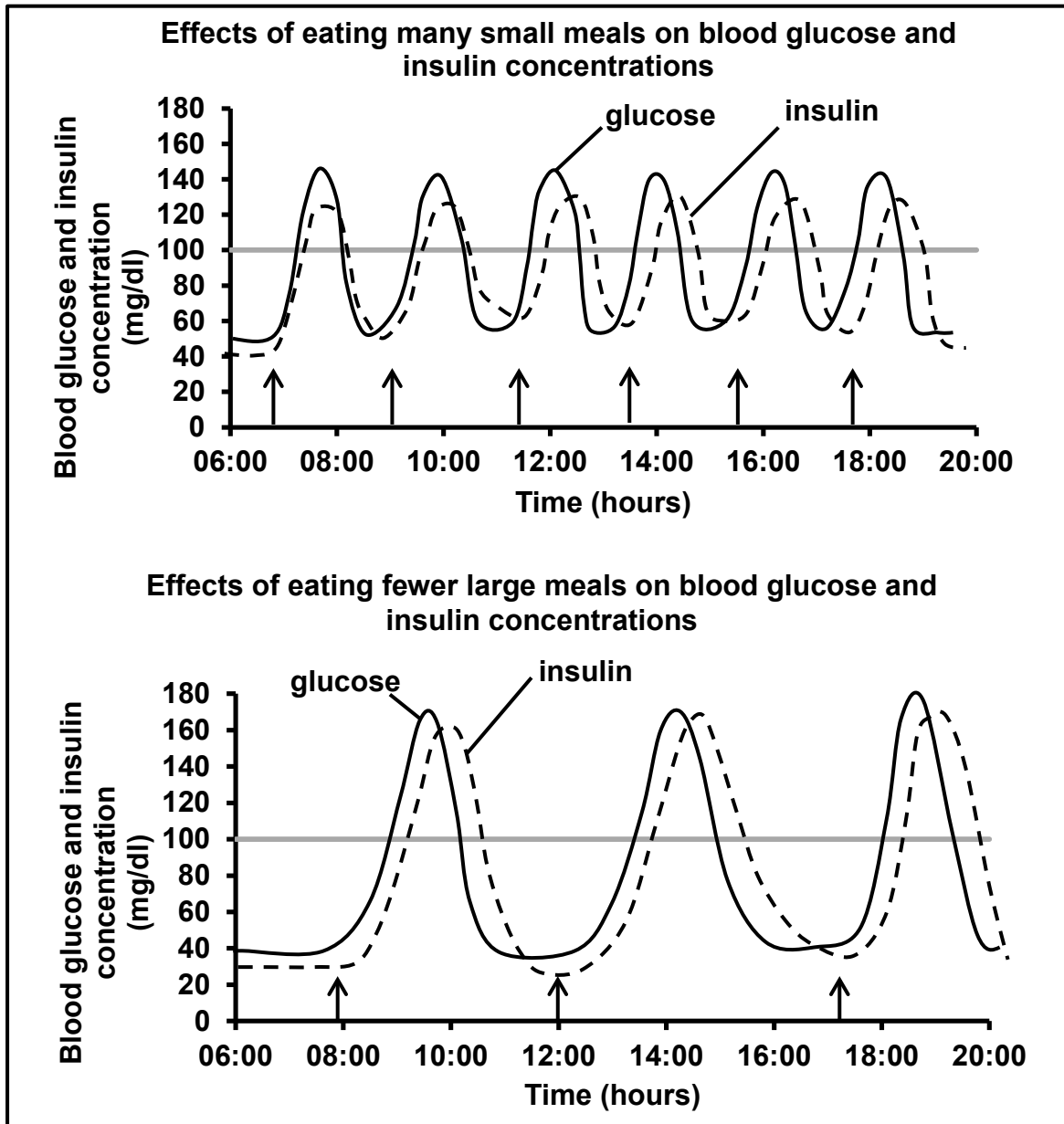

- 3.3.1 State what happens to the blood glucose concentration immediately after a meal is eaten. (1)
  - 3.3.2 Use the information in the graphs.  
 Tabulate TWO ways in which eating fewer large meals and eating many small meals affect the blood insulin levels differently. (5)
  - 3.3.3 Explain why eating many small meals per day is better for a diabetic person than eating fewer large meals a day. (4)
- (10)**

- 3.4 The diagrams below represent structures in the skin of two people. Both people were in the same room at the same time, but one person was exercising while the other person was sitting still. The skin surface temperature of both people was measured after 10 minutes.

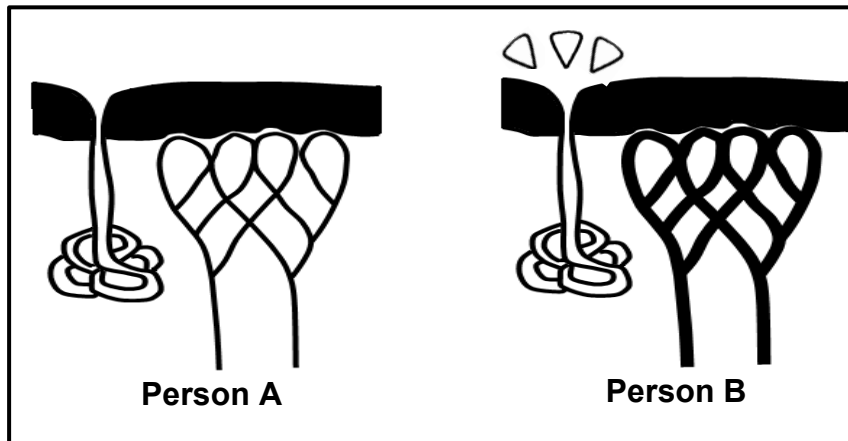

- 3.4.1 Which person, **A** or **B**, was exercising? (1)
- 3.4.2 Give TWO visible reasons for your answer to QUESTION 3.4.1. (2)
- 3.4.3 Name ONE hormone that would have the same effect on the blood vessels that is observable in person **A**. (1)
- 3.4.4 After 10 minutes the surface skin temperature of each person was measured. The results were as follows:
- Person **A**: 37,2 °C
  - Person **B**: 36,6 °C

Explain why the skin temperature of person **A** was higher after 10 minutes. (3)

(7)

**TOTAL SECTION B: 80**

**SECTION C****QUESTION 4**

Describe how human activities have caused rapid global warming over the last century, the impact of global warming on weather patterns and how the change in weather patterns affects food security.

Content: (17)  
Synthesis: (3)  
**(20)**

**NOTE:** NO marks will be awarded for answers in the form of a table, flow charts or diagrams.

**TOTAL SECTION C: 20**  
**GRAND TOTAL: 150**