

SA's Leading Past Year

Exam Paper Portal

STUDY

You have Downloaded, yet Another Great Resource to assist you with your Studies 😊

Thank You for Supporting SA Exam Papers

Your Leading Past Year Exam Paper Resource Portal

Visit us @ www.saexampapers.co.za



SA EXAM
PAPERS



basic education

Department:
Basic Education
REPUBLIC OF SOUTH AFRICA

**NATIONAL
SENIOR CERTIFICATE**

GRADE 12

LIFE SCIENCES P2

NOVEMBER 2018

MARKS: 150

TIME: 2½ hours

This question paper consists of 16 pages.

INSTRUCTIONS AND INFORMATION

Read the following instructions carefully before answering the questions.

1. Answer ALL the questions.
2. Write ALL the answers in the ANSWER BOOK.
3. Start the answers to EACH question at the top of a NEW page.
4. Number the answers correctly according to the numbering system used in this question paper.
5. Present your answers according to the instructions of each question.
6. Do ALL drawings in pencil and label them in blue or black ink.
7. Draw diagrams, tables or flow charts only when asked to do so.
8. The diagrams in this question paper are NOT necessarily drawn to scale.
9. Do NOT use graph paper.
10. You must use a non-programmable calculator, protractor and a compass, where necessary.
11. Write neatly and legibly.

SECTION A**QUESTION 1**

1.1 Various options are provided as possible answers to the following questions. Choose the answer and write only the letter (A to D) next to the question numbers (1.1.1 to 1.1.9) in the ANSWER BOOK, e.g. 1.1.10 D.

1.1.1 What is the scientific name of the fossil, Mrs Ples?

- A *Homo erectus*
- B *Homo habilis*
- C *Australopithecus africanus*
- D *Australopithecus afarensis*

1.1.2 Which ONE of the following is a structural feature of a bipedal organism?

- A Long, narrow pelvis
- B Short, wide pelvis
- C C-shaped vertebral column
- D Longer arms

1.1.3 A mother has blood group **B** and a father has blood group **O**. They have three biological children and an adopted child. The blood groups of all the children are represented in the table below.

CHILDREN	BLOOD GROUP
Nobuhle	O
William	B
Milly	AB
Patrick	O

Which child is adopted?

- A Nobuhle
- B William
- C Milly
- D Patrick

QUESTIONS 1.1.4 AND 1.1.5 ARE BASED ON THE TIMELINE BELOW SHOWING THE POSSIBLE EVOLUTION OF SOME HOMINIDS.

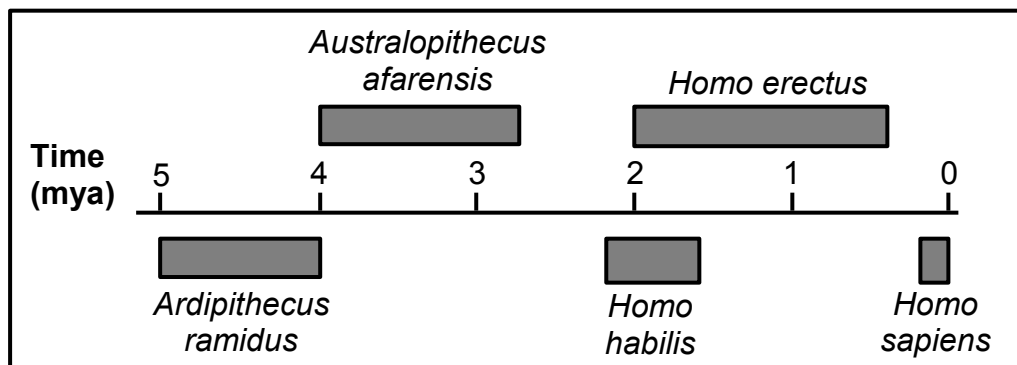

1.1.4 Which species inhabited the Earth for the longest period of time?

- A *Australopithecus afarensis*
- B *Homo erectus*
- C *Homo habilis*
- D *Homo sapiens*

1.1.5 How many years ago did the genus *Homo* first appear?

- A 2,2 mya
- B 2,0 mya
- C 1,6 mya
- D 0,2 mya

1.1.6 The list below describes some evolutionary events.

- (i) Each population undergoes natural selection differently and independently.
- (ii) There is no gene flow between the two populations.
- (iii) A population becomes separated.
- (iv) A geographical barrier forms.
- (v) The two populations become different phenotypically and genotypically.

Which ONE of the following combinations gives the CORRECT sequence of these events?

- A (v) → (iii) → (ii) → (i) → (iv)
- B (iv) → (v) → (ii) → (i) → (iii)
- C (iv) → (iii) → (ii) → (i) → (v)
- D (ii) → (iii) → (iv) → (i) → (v)

- 1.1.7 The diagram below shows the fertility of the offspring produced when three populations of mice, **X**, **Y** and **Z**, interbreed.

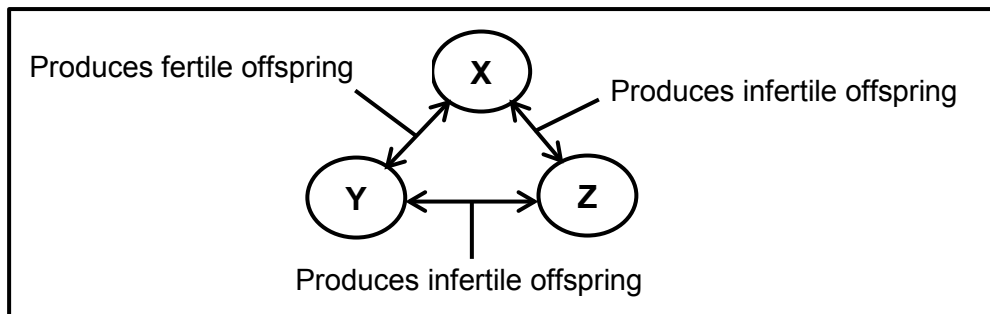

Which ONE of the following statements is CORRECT?

- A All three populations are of the same species.
- B Populations **X** and **Z** are of the same species, but populations **X** and **Y** are different species.
- C Populations **Y** and **Z** are different species, but populations **X** and **Y** are of the same species.
- D Populations **X** and **Y** are different species, but populations **Y** and **Z** are of the same species.

QUESTIONS 1.1.8 AND 1.1.9 ARE BASED ON THE INFORMATION BELOW.

In a certain species of rabbits, body colour is controlled by two alleles where black (**B**) is dominant to white (**b**). Ear shape is controlled by a second gene. The allele for wide ears (**E**) is dominant to the allele for narrow ears (**e**).

- 1.1.8 What is the possible genotype for a black rabbit with narrow ears?

- A BbEe
- B bbee
- C BB Ee
- D Bbee

- 1.1.9 What is the possible genotype of gametes produced by a white rabbit with narrow ears?

- A bbee
- B be
- C BE, Be, bE and be
- D bE and be

(9 x 2) (18)

1.2 Give the correct **biological term** for each of the following descriptions. Write only the term next to the question numbers (1.2.1 to 1.2.9) in the ANSWER BOOK.

- 1.2.1 The bonds between nitrogenous bases in a DNA molecule
- 1.2.2 All the genes that make up an organism
- 1.2.3 The type of evidence for human evolution that includes tool-making
- 1.2.4 The process whereby new species are formed
- 1.2.5 An inherited disorder where blood fails to clot properly
- 1.2.6 The opening in the base of the skull through which the spinal cord passes
- 1.2.7 Two or more alternative forms of a gene at the same locus
- 1.2.8 The type of variation in a population with no intermediate phenotypes
- 1.2.9 Chromosomes involved in sex determination (9 x 1) **(9)**

1.3 Indicate whether each of the statements in COLUMN I applies to **A ONLY**, **B ONLY**, **BOTH A AND B** or **NONE** of the items in COLUMN II. Write **A only**, **B only**, **both A and B** or **none** next to the question numbers (1.3.1 to 1.3.3) in the ANSWER BOOK.

COLUMN I		COLUMN II	
1.3.1	Type of inheritance where both alleles are expressed equally in the phenotype	A:	Co-dominance
		B:	Complete dominance
1.3.2	Evidence of evolution	A:	Modification by descent
		B:	Fossil record
1.3.3	Discovered the structure of the DNA molecule	A:	Watson and Crick
		B:	White and Dart

(3 x 2) **(6)**

1.4 The diagram below shows the structure of a chromosome.

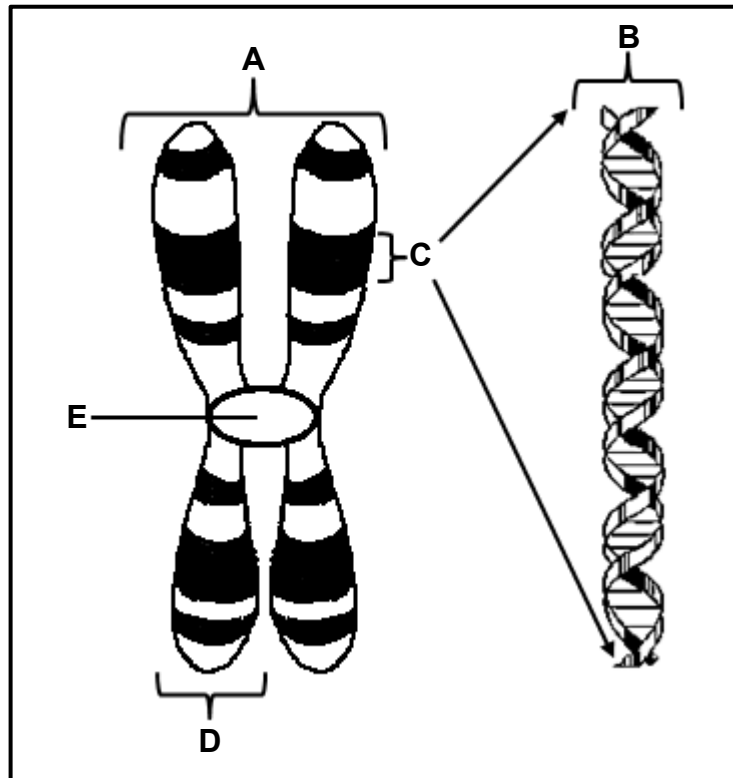

- 1.4.1 Identify parts **D** and **E**. (2)
- 1.4.2 How many pairs of chromosomes are found in a normal human somatic cell? (1)
- 1.4.3 Give only the LETTER of the part that:
- (a) Attaches to the spindle fibres during cell division (1)
- (b) Represents a gene (1)
- 1.4.4 Name:
- (a) TWO organelles in an animal cell where DNA is found (2)
- (b) The natural shape of a DNA molecule (1)
- (c) The process whereby DNA makes an identical copy of itself (1)
- (9)**

1.5 Read the extract below.

Trilobites are an extinct group of marine arthropods. Many of their fossils have been discovered. They had a tough exoskeleton and they are thought to be closely related to three other phyla of extinct arthropods, namely helmetids, tegopeltids and naraoids.

The tegopeltids and helmetids are the two most closely related phyla and are more closely related to trilobites than to naraoids.

Study the diagram below, which illustrates the possible evolutionary relationships among the four phyla, represented by the letters **M**, **N**, **O** and **P**.

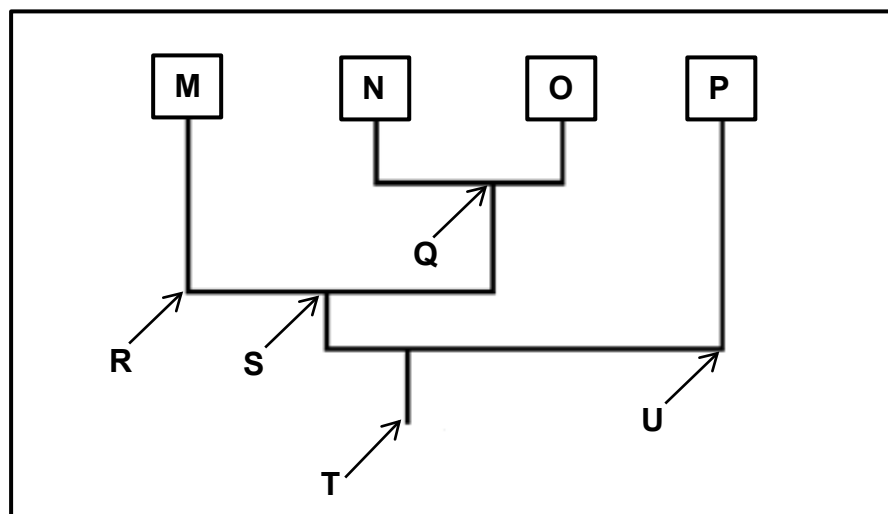

- 1.5.1 Name the type of diagram illustrated. (1)
- 1.5.2 What structural feature of trilobites, described in the extract, improved the chances of fossilisation? (1)
- 1.5.3 Give only the LETTER of the most recent common ancestor for phyla: (1)
- (a) **M** and **O** (1)
- (b) **M**, **N**, **O** and **P** (1)
- 1.5.4 Which of the extinct arthropods (trilobites, helmetids, tegopeltids or naraoids) are represented by phylum: (1)
- (a) **M** (1)
- (b) **N** (1)
- (c) **O** (1)
- (d) **P** (1)
- (8)**

TOTAL SECTION A: 50

SECTION B**QUESTION 2**

- 2.1 The diagrams below represent the distribution of chromosome pair 21 as it appears in gametes at the end of meiosis II in a human male.

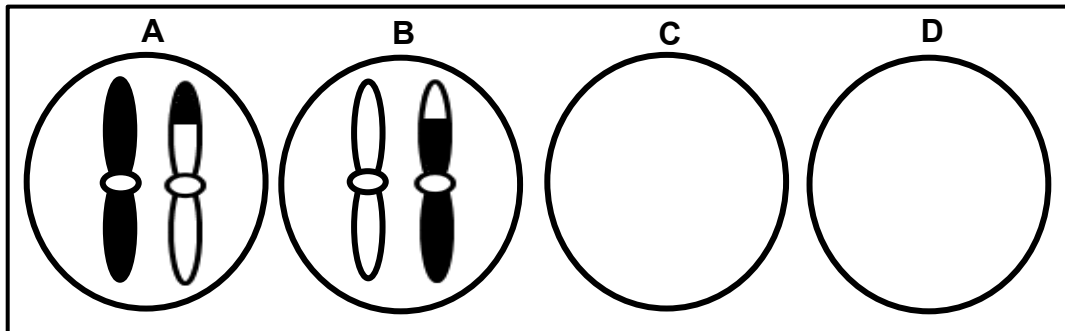

- 2.1.1 Explain why the gametes represented by diagrams **C** and **D** do not have any chromosomes. (3)
- 2.1.2 If gamete **A** is involved in fertilisation, describe how this may result in Down syndrome. (3)
- 2.1.3 Due to the process of crossing over, the chromosomes in diagrams **A** and **B** appear different to each other.
- Identify the phase of meiosis during which crossing over occurs. (1)
 - Describe the events during crossing over. (3)
 - Explain the significance of crossing over in natural selection. (3)
- (13)**

2.2 Severe combined immune deficiency syndrome (SCID) is a disorder affecting the immune system. It is caused by a sex-linked recessive allele (X^d).

The diagram below shows the inheritance of the disorder in a family. It is not known if individual 1 has the disorder or not.

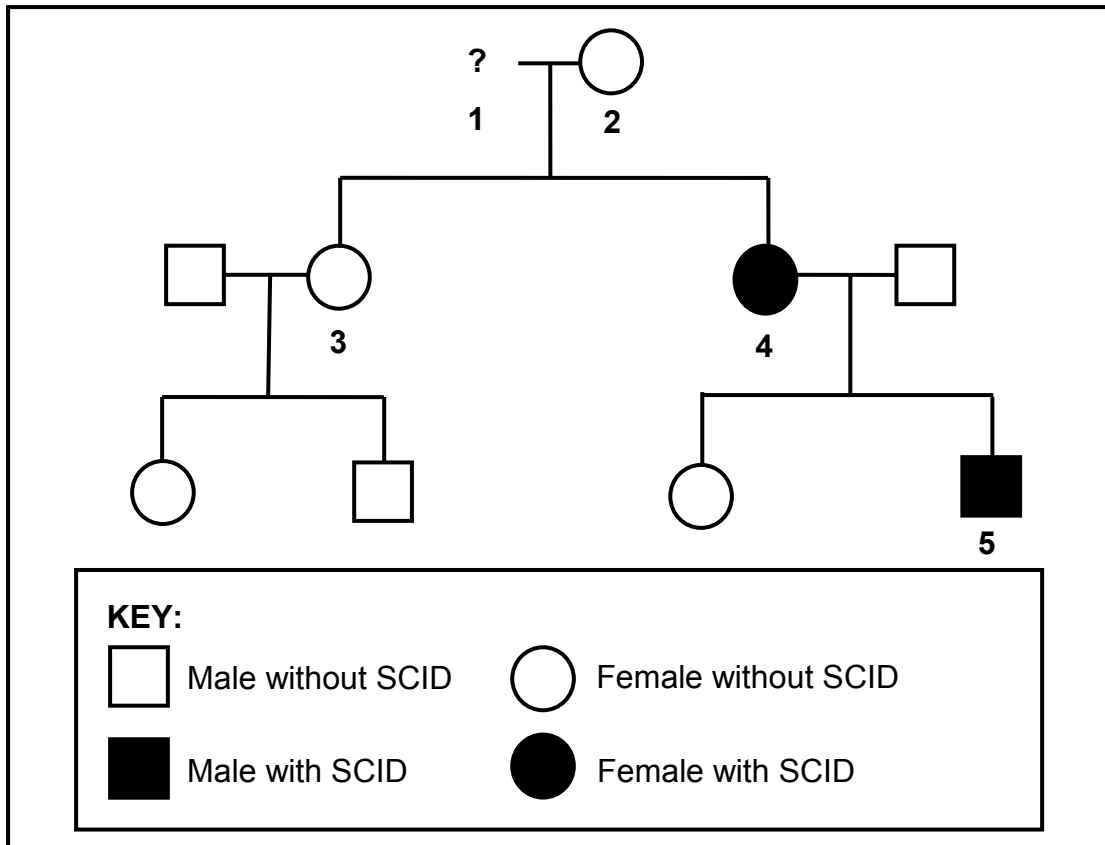

2.2.1 Give the:

- (a) Phenotype of individual 2 (1)
- (b) Phenotype of individual 1 (1)
- (c) Genotype of individual 3 (2)

2.2.2 Explain how individual 5 inherited the disorder. (2)
(6)

2.3 Read the extract below.

The first cloned animal in Africa, a calf named Futhi, was born in North West in South Africa on 19 April 2003. No fertilisation was involved in the production of Futhi. She was produced from a single cell taken from the ear of a donor cow named LMJC 865. The donor cow had a high average milk yield of 78 litres a day. Cloning allows for the production of organisms with desired characteristics.

Some people argue that cloning reduces genetic variation in the offspring, with no further genetic improvement. Cloning is an expensive procedure and may not be economical for commercial agriculture.

2.3.1 According to the extract, state ONE:

(a) Advantage of cloning (1)

(b) Disadvantage of cloning (1)

2.3.2 State why the donor cell was taken from LMJC 865 and not from any other cow. (1)

2.3.3 State why an ear cell was used and not an ovum. (2)

2.3.4 Briefly describe the process of *cloning*. (4)
(9)

2.4 Flower colour (purple or white) in a particular plant species is controlled by two alleles, **D** and **d**.

Four crosses were carried out to determine which allele is dominant. Forty (40) offspring were produced in each cross. The phenotypes of the parents and offspring in each cross were recorded.

The results are shown in the table below.

CROSS	PHENOTYPE		
	PARENT 1	PARENT 2	OFFSPRING
1	purple	white	40 purple
2	purple	purple	31 purple, 9 white
3	white	white	40 white
4	purple	white	21 purple, 19 white

2.4.1 State the dominant flower colour. (1)

2.4.2 Use cross 1 to explain your answer to QUESTION 2.4.1. (2)

2.4.3 State Mendel's Law of Segregation. (3)

2.4.4 Use a genetic cross to show how the crossing of two purple flowering plants can produce white offspring, as in cross 2. (6)
(12)
[40]

QUESTION 3

- 3.1 The diagrams below show the upper jaws of some fossils. These diagrams are drawn to scale.

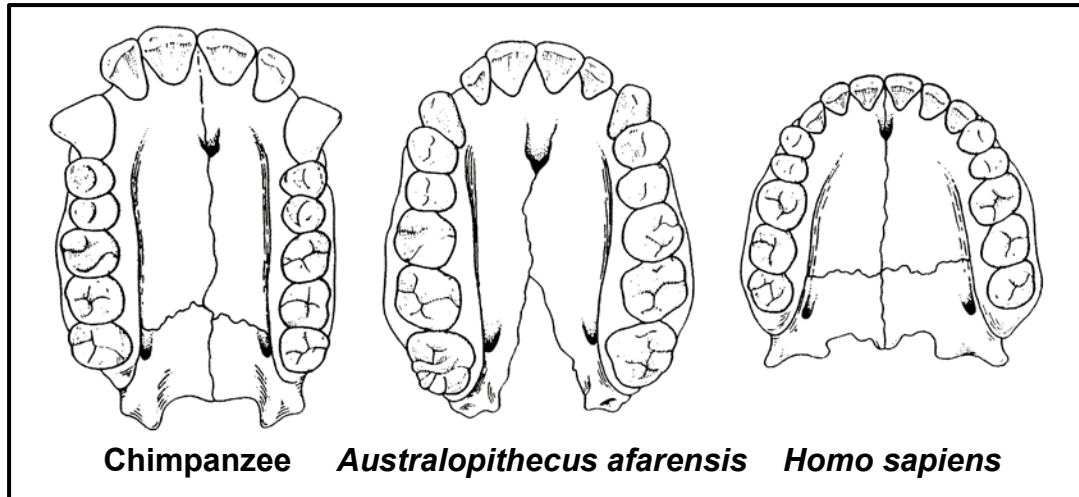

- 3.1.1 Describe ONE visible difference between the jaw of a chimpanzee and that of *Homo sapiens* which show trends in human evolution. (2)
- 3.1.2 Based on the differences in dentition, what conclusion can be made about the change in diet from *Australopithecus afarensis* to *Homo sapiens*? (2)
- 3.1.3 *Australopithecus* may be described as a transitional species between the chimpanzee and *Homo sapiens*.
- (a) Define a *transitional species*. (1)
- (b) Use ONE visible feature of the jaw to explain why *A. afarensis* may be described as a transitional species. (2)
- (7)**

- 3.2 There are two variations in the colour of kingsnakes. Some have a bright colourful pattern and others have a dull pattern. Kingsnakes are non-poisonous to their predators.

Coral snakes also have a bright colour pattern, but are poisonous to their predators. This is a defence mechanism as predators avoid them.

Scientists observed that where kingsnakes shared the same habitat with coral snakes, there were more kingsnakes that had bright colourful patterns.

The diagram below represents the distribution of the snakes.

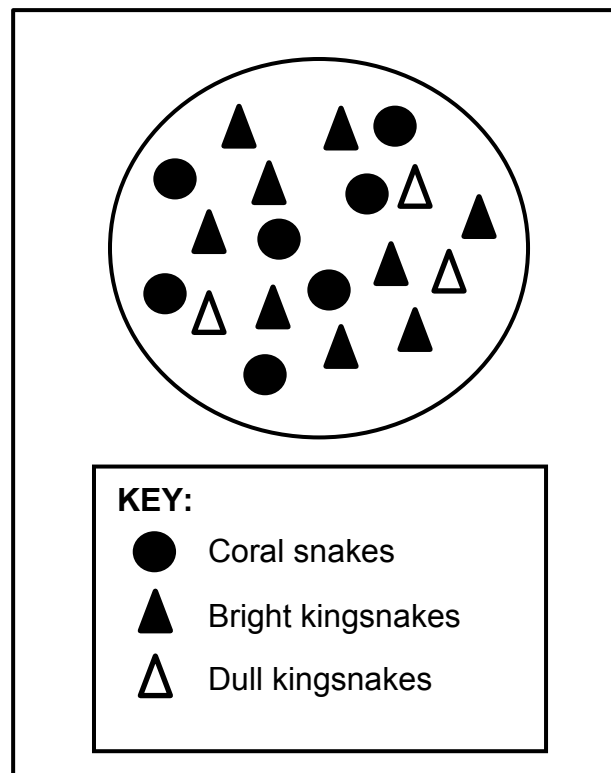

- 3.2.1 Explain how the bright colour pattern of coral snakes influences their survival. (3)
- 3.2.2 Use Darwin's theory of evolution through natural selection to explain why there are more brightly coloured kingsnakes in this habitat. (6)
(9)

- 3.3 Artificial selection programmes have produced two varieties of maize. The one has grains with a high oil content (**Variety F**) and the other has grains with a low oil content (**Variety G**).

The graph below shows the changes in the oil content of the grains of the two varieties over 100 years of artificial selection.

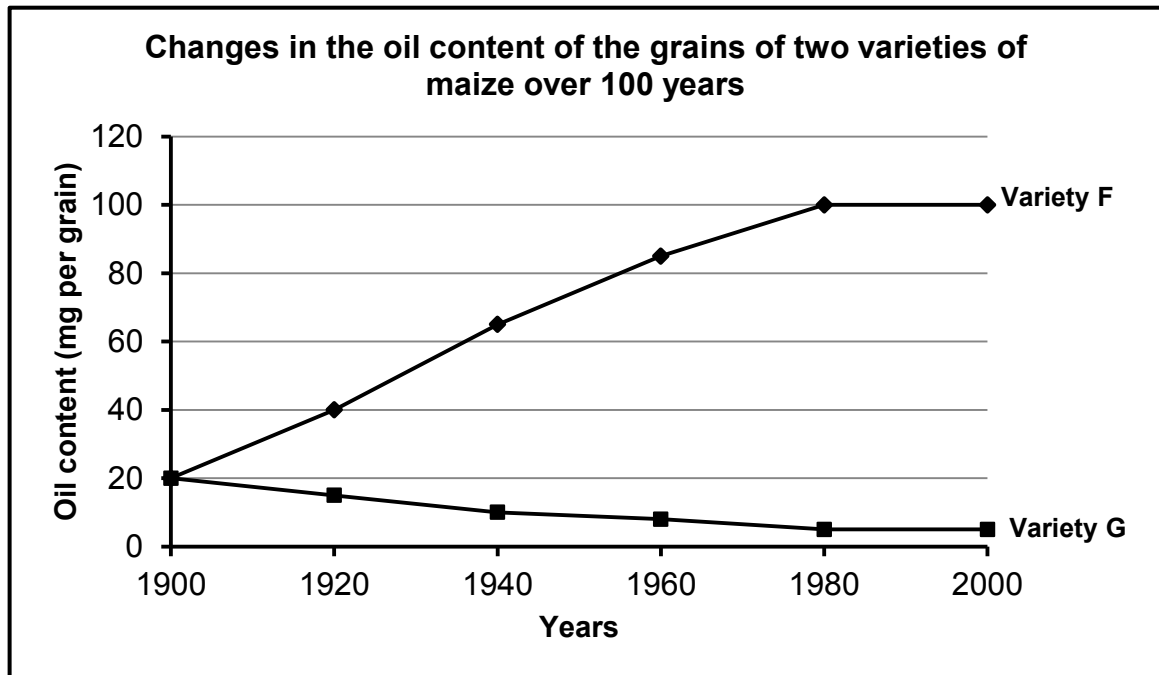

- 3.3.1 In which year did the two maize varieties have the same oil content? (1)
- 3.3.2 Calculate the percentage increase in the oil content of **Variety F** over the 100-year period. Show ALL working. (3)
- 3.3.3 Tabulate TWO differences between natural selection and artificial selection. (5)
(9)

3.4 Weeds are problematic to farmers because they invade farm fields and outcompete crop plants for space. This reduces the crop yield.

Farmers spray their fields with chemicals, known as herbicides, to kill the weeds. Some weeds, however, have evolved to be resistant to herbicides.

Scientists investigated the time it took for a species of weed to develop resistance to five types of herbicides. The results are shown in the table below.

TYPES OF HERBICIDE	TIME TAKEN FOR WEEDS TO DEVELOP RESISTANCE (YEARS)
2,4-D	9
Dalapon	9
Picloran	25
Diclofop	7
Trifluralin	26

- 3.4.1 Refer to the passage above and state how weeds act to reduce crop yield. (1)
- 3.4.2 Identify the:
- (a) Independent variable (1)
- (b) Dependent variable (1)
- 3.4.3 Name the herbicide:
- (a) To which the weeds developed resistance the fastest (1)
- (b) That remained effective for the longest period of time (1)
- 3.4.4 The scientists used the same weed species when investigating resistance to the different herbicides.
- (a) Describe how the scientists would have determined the resistance of the weeds to the herbicides. (2)
- (b) Explain how the use of the same weed species improved the validity of the investigation. (2)
- 3.4.5 Draw a bar graph to show the time taken for the evolution of resistance to the herbicides. (6)
- (15)**
[40]

TOTAL SECTION B: 80

SECTION C**QUESTION 4**

Describe the structure of RNA in a cell and the involvement of the different types of RNA in protein synthesis.

Content: (17)
Synthesis: (3)
(20)

NOTE: NO marks will be awarded for answers in the form of a table, flow charts or diagrams.

TOTAL SECTION C: 20
GRAND TOTAL: 150