

SA's Leading Past Year

Exam Paper Portal

STUDY

You have Downloaded, yet Another Great Resource to assist you with your Studies 😊

Thank You for Supporting SA Exam Papers

Your Leading Past Year Exam Paper Resource Portal

Visit us @ www.saexampapers.co.za



SA EXAM
PAPERS



KWAZULU-NATAL PROVINCE

**EDUCATION
REPUBLIC OF SOUTH AFRICA**

**NATIONAL
SENIOR CERTIFICATE**

GRADE 12

**LIFE SCIENCES P2
PREPARATORY EXAMINATION
SEPTEMBER 2021**

MARKS: 150

TIME: 2½ hours

This question paper consists of 18 pages.

INSTRUCTIONS AND INFORMATION

Read the following instructions carefully before answering the questions.

1. Answer ALL the questions.
2. Write ALL the answers in the ANSWER BOOK.
3. Start the answers to each question at the top of a NEW page.
4. Number the answers correctly according to the numbering system used in this question paper.
5. Present your answers according to the instructions of each question.
6. Do ALL drawings in pencil and label them in blue or black ink.
7. Draw diagrams, tables or flow charts only when asked to do so.
8. The diagrams in this question paper are NOT necessarily drawn to scale.
9. Do NOT use graph paper.
10. You may use a non-programmable calculator, protractor and a compass.
11. Write neatly and legibly.

SECTION A**QUESTION 1**

1.1 Various options are provided as possible answers to the following questions. Choose the answer and write only the letter (A to D) next to the question number (1.1.1 to 1.1.9) in the ANSWER BOOK, for example 1.1.10 D.

1.1.1 Lamarck's 'laws' of use and disuse and inheritance of acquired characteristics were rejected, because the evidence shows that ...

- A only characteristics that benefit offspring can be inherited.
- B organisms evolved randomly in response to the environment not because they wanted to change
- C organisms evolved as a result of mutation only
- D only characteristics that are coded for in the gonosomes can be inherited.

1.1.2 Study the evidence of evolution below:

- (i) Biogeography
- (ii) Cultural evidence
- (iii) Modification by descent
- (iv) Fossil evidence

Which ONE of the following combinations represents evidence supporting the 'out of Africa' hypothesis?

- A (i) and (ii) only
- B (i), (iii) and (iv) only
- C (ii) and (iv) only
- D (i), (ii), (iii) and (iv)

1.1.3 Which of the following scientists showed that the DNA is double helix?

- A Watson and Crick
- B Watson and Franklin
- C Franklin and Crick
- D Franklin and Wilkins

QUESTIONS 1.1.4 AND 1.1.5 REFER TO THE DIAGRAMS SHOWING SOME PHASES OF MEIOSIS BELOW.

(The diagrams are not necessarily in the correct order)

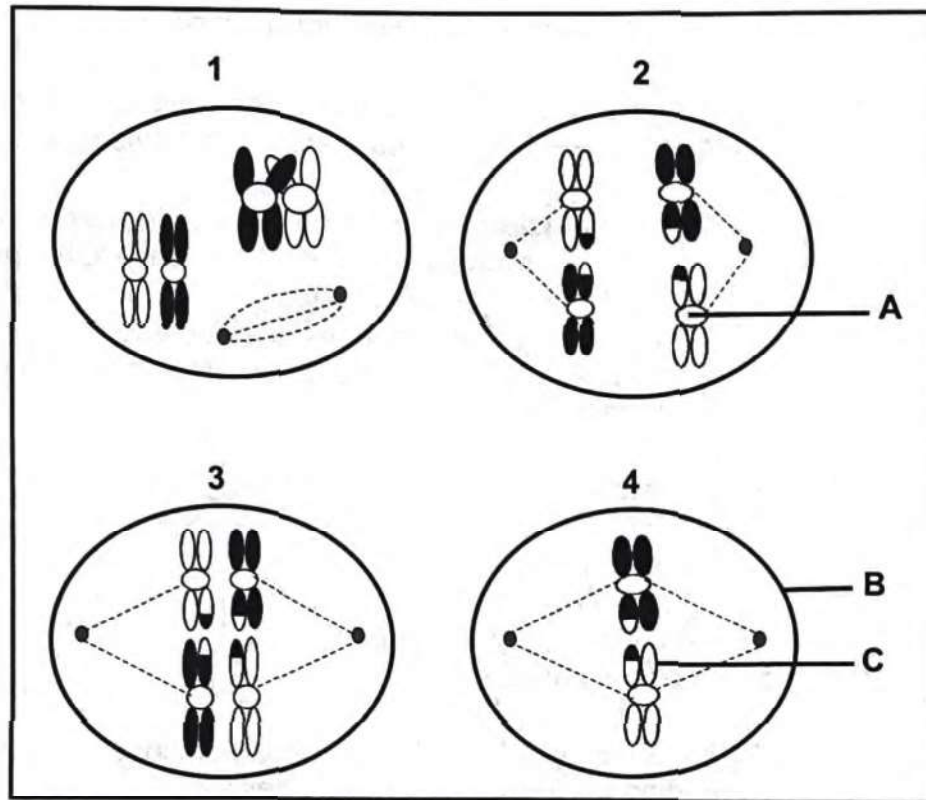

1.1.4 Which ONE of the following is CORRECT regarding labels A, B and C in the diagrams?

	A	B	C
A	Centrosome	Cell wall	Chromatid
B	Centromere	Cell membrane	Chromosome
C	Centromere	Cell membrane	Chromatid
D	Centrosome	Cell membrane	Chromatid

1.1.5 Which ONE of the following shows the correct sequence of the phases in meiosis?

- A 3, 1, 2, 4
- B 2, 1, 3, 4
- C 1, 3, 2, 4
- D 1, 2, 3, 4

- 1.1.6 A mule is the offspring of a male donkey and a female horse. It has 63 chromosomes in its somatic cells.

Which ONE of the following shows the cell condition and the number of chromosomes in each somatic cell of the donkey and the horse respectively?

	CELL CONDITION	NUMBER OF CHROMOSOMES	
		Donkey	Horse
A	Diploid	62	64
B	Haploid	62	64
C	Haploid	31	32
D	Diploid	31	32

- 1.1.7 A person infected with TB-causing bacteria was treated with a full course of antibiotics. A few months later, the infection returned.

According to Darwin's theory of evolution, one can conclude that ...

- A the bacteria became immune to the antibiotic.
 B antibiotics were not having effect on bacteria.
 C the decrease in the infection allowed the bacteria to develop resistance to the antibiotics.
 D the resistant bacteria were present at the start of treatment and that natural selection increased their numbers.
- 1.1.8 Fragile X syndrome (FXS) is a genetic disorder and can cause mild intellectual disability. It is inherited as a dominant allele on the X chromosome.

A man who is not affected by FXS and a woman, who is heterozygous for this condition, have two children, a boy and a girl.

Which ONE of the following is CORRECT about the inheritance of FXS in these children?

- A Both children have a 50% chance of having FXS
 B The girl has a 0% chance of having FXS and the boy has a 100% chance
 C The girl has a 50% chance of having FXS and the boy has a 0% chance
 D Both children have a 0% chance of having FXS

- 1.1.9 Anna and David's son died in a car accident. The car ended in flames and dead bodies were not recognisable by family members. DNA profiling was the only solution to identify dead body of Anna and David's son.

The diagram below shows the DNA profiles of David, Anna and four dead bodies that were not recognisable.

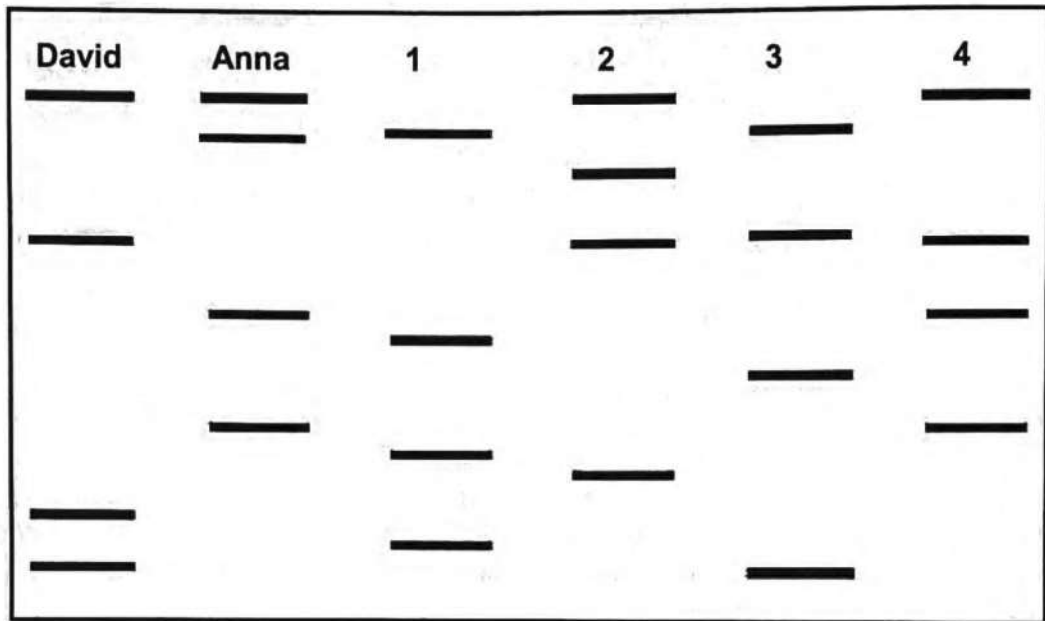

Which ONE of the following DNA profiles is most likely to be Anna and David's son?

- A 1
- B 2
- C 3
- D 4

(9 x 2) (18)

1.2 Give the correct **biological term** for each of the following descriptions. Write only the term next to the question number (1.2.1 to 1.2.10) in the ANSWER BOOK.

- 1.2.1 The bond between amino acids in a protein molecule
- 1.2.2 Type of sugar found in a nucleotide of DNA
- 1.2.3 Chromosomes that are similar in structure and code for the same characteristics
- 1.2.4 A single set of chromosomes in the cell of an organism
- 1.2.5 The chromosomes that determine the gender of an individual
- 1.2.6 The type of variation within a population in which there is a no range of intermediate phenotypes
- 1.2.7 The breeding of organisms for desirable characteristics, selected by humans
- 1.2.8 The type of evolution where species experience long periods without any change, followed by short periods of rapid change
- 1.2.9 An intermediate fossil showing some features of a more primitive species and some features of a more advanced species
- 1.2.10 An explanation for something that has been observed in nature, and which can be supported by facts

(10 x 1) (10)

1.3 Indicate whether each of the descriptions in COLUMN I applies to **A ONLY**, **B ONLY**, **BOTH A AND B** or **NONE** of the items in COLUMN II. Write **A only**, **B only**, **both A and B**, or **none** next to the question number (1.3.1 to 1.3.3) in the ANSWER BOOK.

	COLUMN I	COLUMN II
1.3.1	The location of DNA molecule in an animal cell	A: Mitochondrion B: Nucleus
1.3.2	A segment of a chromosome that codes for a particular characteristic	A: Gene B: Genome
1.3.3	The phase in meiosis where chromatids are pulled to opposite poles of a cell	A: Anaphase I B: Anaphase II

(3 x 2) (6)

1.4 The diagram below shows a stage in protein synthesis.

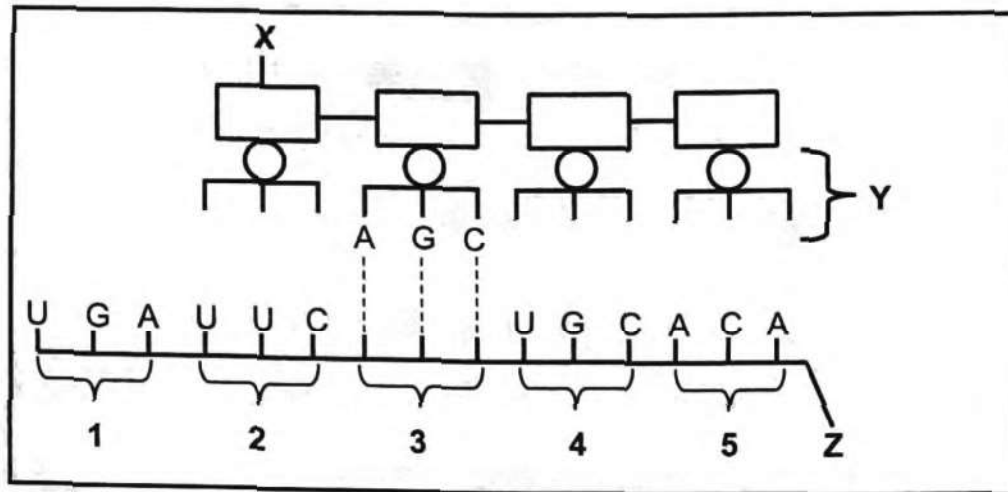

1.4.1 Identify molecule:

(a) X (1)

(b) Y (1)

1.4.2 Name the stage of protein synthesis represented by the diagram above. (1)

1.4.3 Give the:

(a) DNA base triplet that correspond to the codon numbered 3 (1)

(b) Anticodon for the codon numbered 5 (1)

1.4.4 Name the organelle in a cell where the process shown in the diagram above occurs. (1)

1.4.5 From which molecule does Z copy the coded message during protein synthesis? (1)

1.4.6 Where is the molecule Y located in the cell? (1)

(8)

- 1.5 In humans the allele for unattached earlobes (**E**) is dominant over the allele for attached earlobes. The allele for the ability to roll the tongue (**T**) is dominant over the allele for inability to roll the tongue (**t**).

A female that is heterozygous for both unattached earlobe and ability to roll the tongue is married to a male that has attached earlobe and is heterozygous for the ability to roll the tongue.

- 1.5.1 How many characteristics of humans are being investigated in the statement above? (1)
- 1.5.2 Give the:
- (a) Genotype of the female (2)
 - (b) Phenotype of the male (2)
 - (c) Genotypes of all the possible gametes of the male (2)
- 1.5.3 Name Mendel's law that allows an allele for unattached earlobe to show up in a phenotype of a heterozygous individual. (1)

(8)

TOTAL SECTION A: 50

SECTION B**QUESTION 2**

2.1 The diagram below represents a DNA molecule.

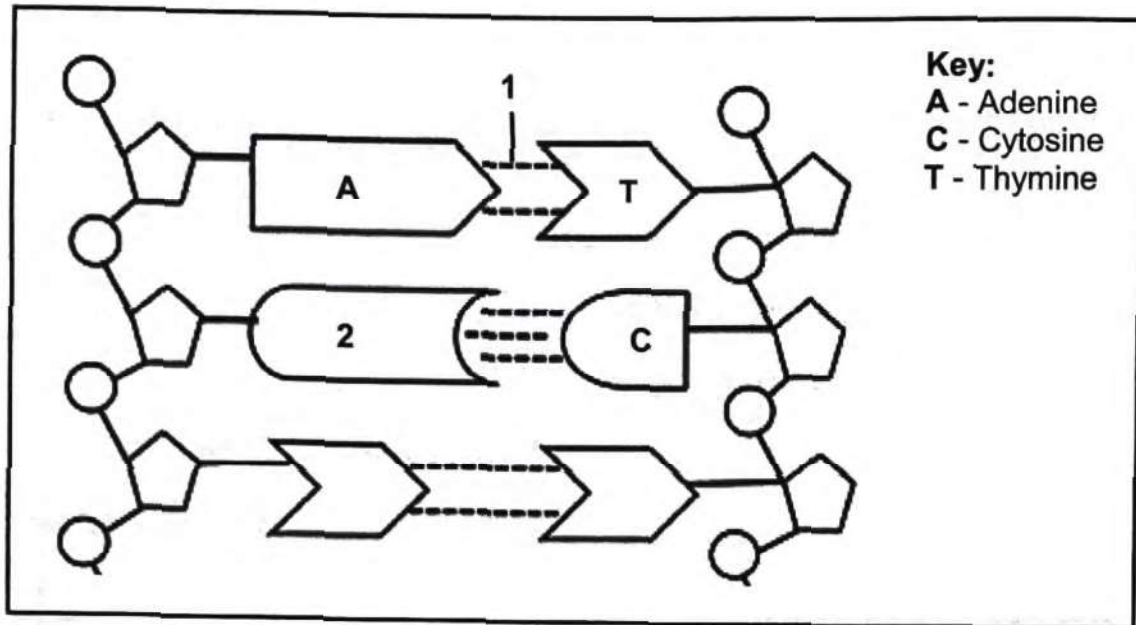

2.1.1 Identify:

(a) Bond 1

(1)

(b) Nitrogenous base 2

(1)

2.1.2 Give TWO reasons for identifying this molecule above as DNA.

(2)

2.1.3 Name the phase of the cell cycle during which this molecule makes a copy of itself.

(1)

(5)

2.2 Describe the structure of RNA molecule.

(6)

2.3 The diagram below shows a human male karyotype.

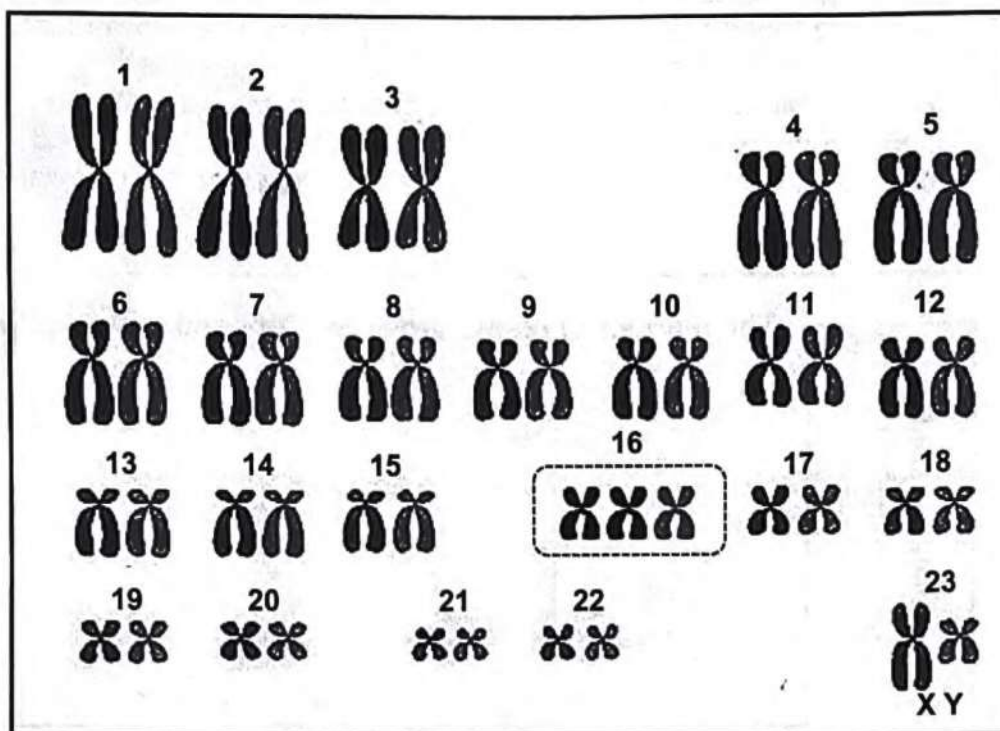

- 2.3.1 Name the origin of chromosome **X** in pair number 23. (1)
- 2.3.2 How many: (1)
- (a) Autosomes are found in the karyotype above? (1)
- (b) Cells will carry the Y-chromosome at the end of meiosis? (1)
- 2.3.3 Explain the events that led to the number of chromosomes in chromosome pair number **16** in the diagram above. (4)
(7)
- 2.4 Describe the process in prophase I that results in genetic variation. (4)

- 2.5 A gardener had orange-flowering plants growing in her garden. She collected seeds from the plants and planted them. When the plants of the F1 generation matured, she found that some of the plants produced red flowers (R), some produced yellow flowers (Y) and some produced orange flowers.
(Note: when red and yellow are mixed, orange is produced)

The graph below shows the number of plants produced for each flower colour.

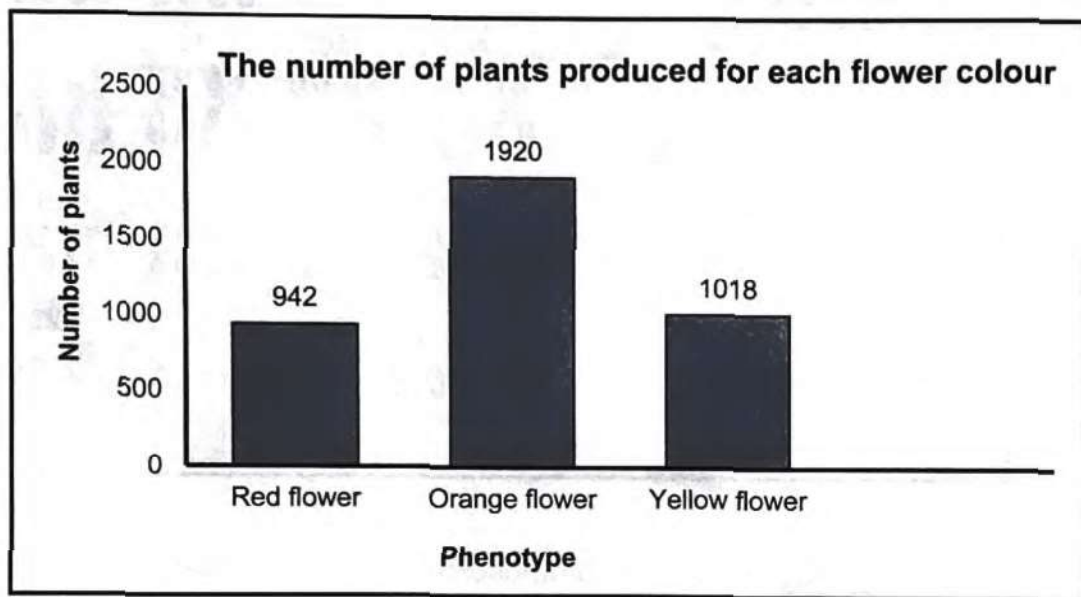

- 2.5.1 Name the type of dominance displayed in the inheritance of orange-flowering plants. (1)
- 2.5.2 What is the ratio of red flowers to orange flowers as shown in the graph above? (1)
- 2.5.3 Calculate the percentage of red flowers produced in the F1 generation in this garden. Show all working. (3)
- 2.5.4 Use a genetic cross to show how the cross between two orange-flowering plants can produce red-flowering plants. (6)
(11)
- 2.6 Explain how blood grouping is used in paternity testing. (6)

- 2.7 Hunter syndrome is a sex-linked disorder that is inherited as a recessive allele t on the X chromosome.

The diagram below shows the inheritance of a Hunter syndrome in a family.

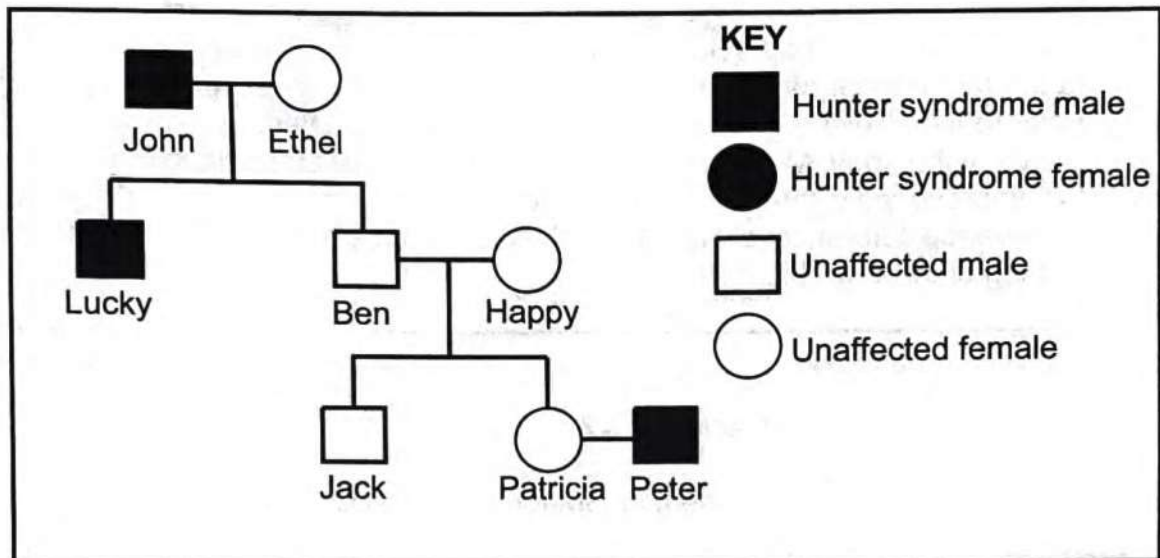

- 2.7.1 Give the:
- (a) Phenotype of Peter (1)
- (b) Possible genotype(s) of Happy (2)
- 2.7.2 Identify the female member in the diagram above who is a definite heterozygous. (1)
- 2.7.3 Give the percentage of unaffected males in the diagram above. (2)
- 2.7.4 Explain why Lucky's condition cannot be used as evidence that John is his father. (5)
- (11)**
[50]

QUESTION 3

3.1 Read the passage below.

GENETIC MODIFICATION

Genetically modified (GM) foods are foods derived from organisms whose genetic material has been modified through the introduction of a gene from a different organism. The technology is often called biotechnology or recombinant DNA technology. Most existing genetically modified crops have been developed to improve yield through the introduction of resistance to plant diseases or of increased tolerance of herbicides. All GM foods should be assessed before being allowed on the market.

- 3.1.1 What is *biotechnology*? (2)
- 3.1.2 State ONE benefit of GM foods in the passage. (1)
- 3.1.3 Explain why GM foods should be assessed before being allowed in the market. (2)
- (5)

3.2 Bt-maize is a crop that is genetically modified to be insect resistant.

An investigation was conducted to determine if plants with the Bt-gene are insect resistant.

The procedure was as follows:

- A total of 400 maize seeds was divided into two equal groups
- A field was divided into two equal plots (X and Y).
- On plot X, 200 seeds without the Bt-gene were grown.
- On plot Y, 200 seeds with the Bt-gene were grown.
- Both plots were exposed to the same environmental conditions suitable for growth of crops.
- 200 insects of the same type were introduced into both plots.
- The maize plants that were resistant to the insects started producing flowers after 5 weeks and all the maize plants with flowers were counted in both plots X and Y.
- The average grain yield in each plot was calculated and used as an indication of insect resistance.

The results are shown in the table below.

PLOT	THE AVERAGE PERCENTAGE OF GRAIN YIELD PER PLOT
X	19
Y	38

- 3.2.1 Identify the dependent variable in this investigation. (1)
- 3.2.2 Describe how the dependent variable in QUESTION 3.2.1 was determined. (1)
- 3.2.3 State TWO ways in which the validity of the investigation was ensured. (2)
- 3.2.4 Why was plot X included in this investigation? (3)
- 3.2.5 State why 400 maize seeds were used in the investigation instead of 100 only. (1)
- (8)**

- 3.3 The diagrams below show the skulls, teeth and pelvis of two organisms, not necessarily belonging to the same organism.

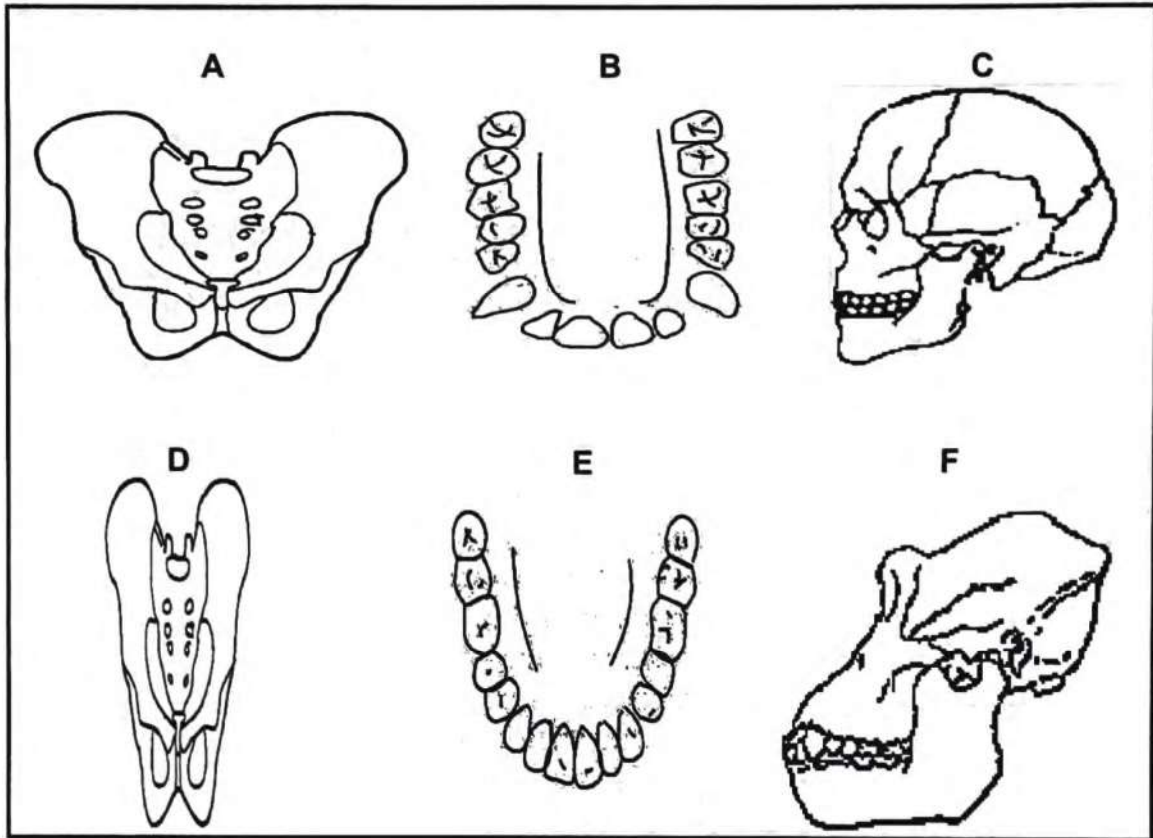

3.3.1 Which of the diagrams (D, E or F) belong/s to:

- (a) The family Hominidae (1)
- (b) African apes (2)

3.3.2 Explain how the change in the pelvis from D to A supports bipedalism in humans. (3)

3.3.3 Explain the advantage of the size of cranium in diagram C. (2)

3.3.4 Describe the significance of the position of the foramen magnum in diagram C as a trend in human evolution. (2)

3.3.5 Explain the relationship between the evolution of the dentition in the organism in diagram E and the early use of fire by humans. (3)

(13)

3.4 Read the passage below.

REPRODUCTIVE ISOLATING MECHANISM (RIM)

When scientists mated a male lion with a female tiger, the resulting offspring was called a *liger*. In nature, interbreeding between these different species is prevented by the prevention of the fertilisation of the egg, differences in behaviour and by non-biological factors such as differences in range. Usually, male ligers and many female ligers that arise by accident do not develop functional sex cells. Such hybrid sterility prevents the formation of viable or fertile offspring.

This RIM prevents the formation of hybrids between members of different populations and reduces the viability or fertility of hybrids

- 3.4.1 Name THREE reproductive isolating mechanisms in the passage above. (3)
- 3.4.2 What is the product of breeding a male lion and a female tiger? (1)
(4)
- 3.5 Describe how speciation occurs through geographic isolation. (7)

3.6 The diagram below represents a phylogenetic tree.

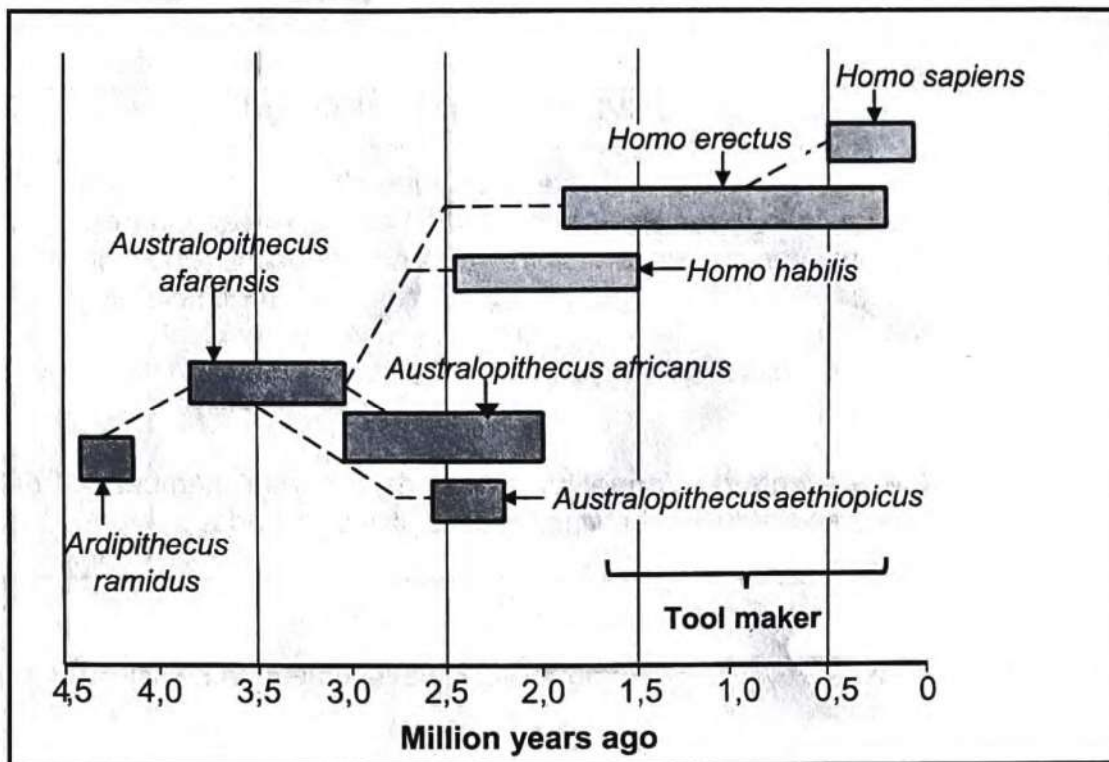

3.6.1 State how:

- (a) Many genera are represented in the diagram above? (1)
- (b) Long ago did *Homo sapiens* evolve? (1)

3.6.2 Name TWO species in the diagram that:

- (a) Would have competed with the *Australopithecus aethiopicus* for resources. (2)
- (b) Were able to use tools. (2)

3.6.3 According to this diagram, which genus is most recently evolved? (1)
(7)

3.7 Describe the process of evolution by natural selection. (6)
[50]

TOTAL SECTION B: 100

GRAND TOTAL: 150