

SA's Leading Past Year

Exam Paper Portal

STUDY

You have Downloaded, yet Another Great Resource to assist you with your Studies 😊

Thank You for Supporting SA Exam Papers

Your Leading Past Year Exam Paper Resource Portal

Visit us @ www.saexampapers.co.za



SA EXAM
PAPERS



basic education

Department:
Basic Education
REPUBLIC OF SOUTH AFRICA

NATIONAL SENIOR CERTIFICATE

GRADE 12

ELECTRICAL TECHNOLOGY

FEBRUARY/MARCH 2012

MARKS: 200

TIME: 3 hours

This question paper consists of 12 pages and 1 formula sheet.

INSTRUCTIONS AND INFORMATION

1. Answer ALL the questions.
2. Sketches and diagrams must be large, neat and fully labelled.
3. Show ALL calculations, correctly rounded off to TWO decimal places.
4. Number the answers correctly according to the numbering system used in this question paper.
5. Non-programmable calculators may be used.
6. Show the unit for all answers of calculations.
7. A formula sheet is provided at the end of this question paper.
8. Write neatly and legibly.

QUESTION 1: TECHNOLOGY, SOCIETY AND ENVIRONMENT

- 1.1 Describe why it is neither ethical nor legal to expect a person to work on electrical equipment without the required training. (3)
- 1.2 When an entrepreneur wishes to promote a new product, he must firstly do market research. Give TWO reasons why, and describe why they are important. (4)
- 1.3 Global warming is creating a huge negative impact on our society and environment. List THREE suitable energy sources that have little negative impact on the environment. (3)
[10]

QUESTION 2: TECHNOLOGICAL PROCESS

- 2.1 With reference to the design problem in your PAT project, name THREE of the technological steps that must be followed. (3)
- 2.2 Give THREE reasons why it is important to follow the technological process in the completion of an artefact/project. (3)
- 2.3 The design of the circuit board used in your PAT is important. Describe, giving TWO reasons why this is important. (4)
[10]

QUESTION 3: OCCUPATIONAL HEALTH AND SAFETY

- 3.1 State why it is dangerous to use water to extinguish an electrical fire. (2)
- 3.2 Explain why it is important to have the correct level of lighting in an electrical technology workshop. (2)
- 3.3 Name TWO ways in which HIV/Aids can be transmitted between humans. (2)
- 3.4 Describe how an earth-leakage unit can protect a person from electrical shock when using a faulty electrical appliance. (2)
- 3.5 Name ONE essential piece of safety equipment that must be used when working with a grinding machine. (1)
- 3.6 Give ONE reason why it is important to maintain tools in a good condition. (1)
[10]

QUESTION 4: THREE-PHASE AC GENERATION

- 4.1 Name TWO advantages of a three-phase system in comparison with a single-phase system. (2)
- 4.2 Power distribution to all consumers is done in the star connection. Explain why. (2)
- 4.3 A three-phase balanced load is connected in delta across a 380 V supply. The load current is 5 A with a power factor of 0,9.

Given:

$$V_L = 380 \text{ V}$$

$$I_L = 5 \text{ A}$$

$$\text{Cos}\theta = 0,9$$

Calculate the following:

- 4.3.1 The current in each phase of the load (3)
- 4.3.2 The total power dissipated by the load (3)
- [10]**

QUESTION 5: RLC CIRCUITS

- 5.1 What will happen to the brightness of an incandescent lamp, connected in series with an RC circuit, if the frequency of the supply is decreased? (1)
- 5.2 Name ONE disadvantage of a poor power factor. (1)
- 5.3 A capacitor with a capacitive reactance of 250 Ω , an inductor with an inductive reactance of 300 Ω and a resistor with a resistance of 500 Ω are all connected in series to a 220 V/50 Hz supply.

Given:

$$X_C = 250 \Omega$$

$$X_L = 300 \Omega$$

$$R = 500 \Omega$$

$$V_S = 220 \text{ V}$$

$$f = 50 \text{ Hz}$$

- 5.3.1 Draw a labelled circuit diagram. (4)
- 5.3.2 Calculate the total impedance of the circuit. (3)
- 5.3.3 Calculate the power factor of the circuit and state whether it is leading or lagging. (4)

5.4 Refer to the circuit in FIGURE 5.1.

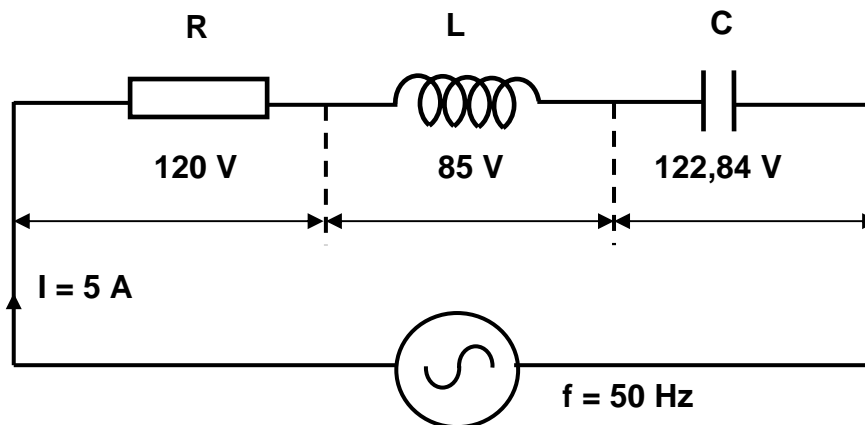

FIGURE 5.1: RLC SERIES CIRCUIT

Given:

$$V_R = 120 \text{ V}$$

$$V_L = 85 \text{ V}$$

$$V_C = 122,84 \text{ V}$$

$$I_S = 5 \text{ A}$$

$$f = 50 \text{ Hz}$$

Calculate the following:

- 5.4.1 The supply voltage (3)
- 5.4.2 The inductive reactance of the inductor (3)
- 5.4.3 The capacitive reactance the capacitor (3)
- 5.4.4 The capacitance of the capacitor (3)
- 5.4.5 Draw the phasor diagram of the circuit. Indicate the direction of rotation. (5)

[30]

QUESTION 6: SWITCHING AND CONTROL CIRCUITS

- 6.1 Draw a fully labelled symbol of an SCR. (3)
- 6.2 Describe ONE method to switch an SCR on. (3)
- 6.3 The diagram in FIGURE 6.1 is the characteristic curve of an SCR. With reference to FIGURE 6.1, answer the following questions:

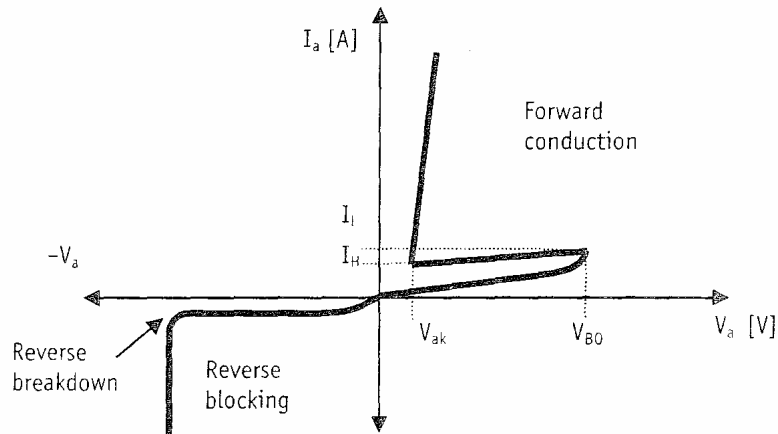
**FIGURE 6.1: CHARACTERISTIC CURVE OF AN SCR**

- 6.3.1 Explain what occurs at reverse breakdown voltage. (3)
- 6.3.2 When the SCR is conducting (refer to FIGURE 6.1), what would the voltage drop across the SCR be? (1)
- 6.3.3 When the SCR is conducting, describe what determines the current flow through the SCR. (2)
- 6.3.4 If the current flowing through the SCR drops below I_H , what will occur? (2)

6.4 The lamp-dimming circuit in FIGURE 6.2 is connected to a 220 V/50 Hz supply.

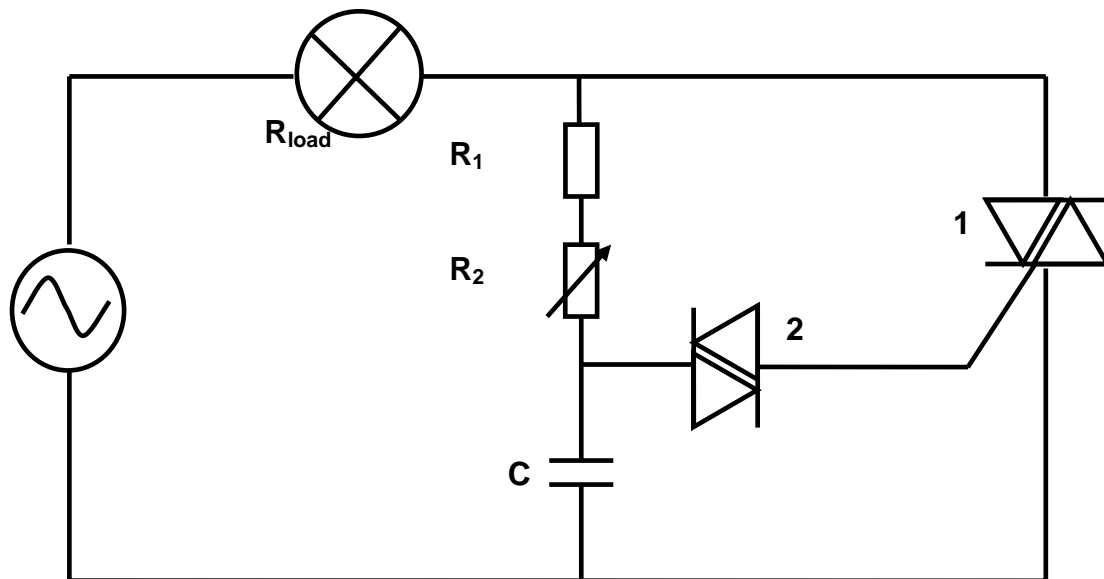

FIGURE 6.2: LAMP-DIMMING CIRCUIT

6.4.1 Name the components marked 1 and 2. (2)

6.4.2 If the value of R_2 is decreased, the brightness of the lamp will increase. Explain how this occurs. (6)

6.4.3 Explain the function of R_1 . (2)

6.5 Name ONE advantage of THYRISTOR control when compared to RESISTOR control. (1)
[25]

QUESTION 7: AMPLIFIERS

7.1 Redraw and complete the table in FIGURE 7.1 in your ANSWER BOOK.

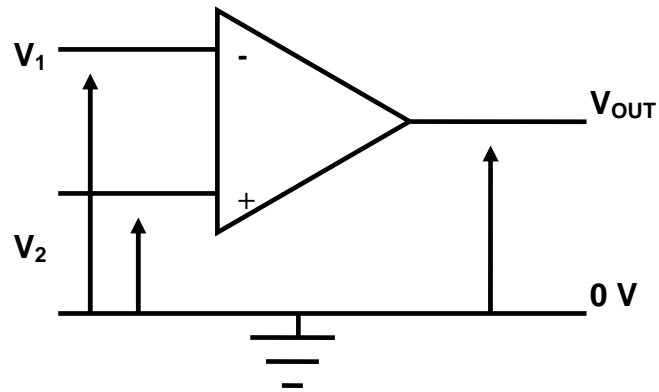

INPUT	OUTPUT
If $V_1 > V_2$	$V_{OUT} =$
If $V_1 < V_2$	$V_{OUT} =$
If $V_1 = V_2$	$V_{OUT} =$

FIGURE 7.1: OP-AMP

(3)

7.2 Draw a non-inverting voltage comparator using an op-amp.

(5)

7.3 Describe the working principle of an op-amp.

(3)

7.4 Answer the following questions with reference to FIGURE 7.2.

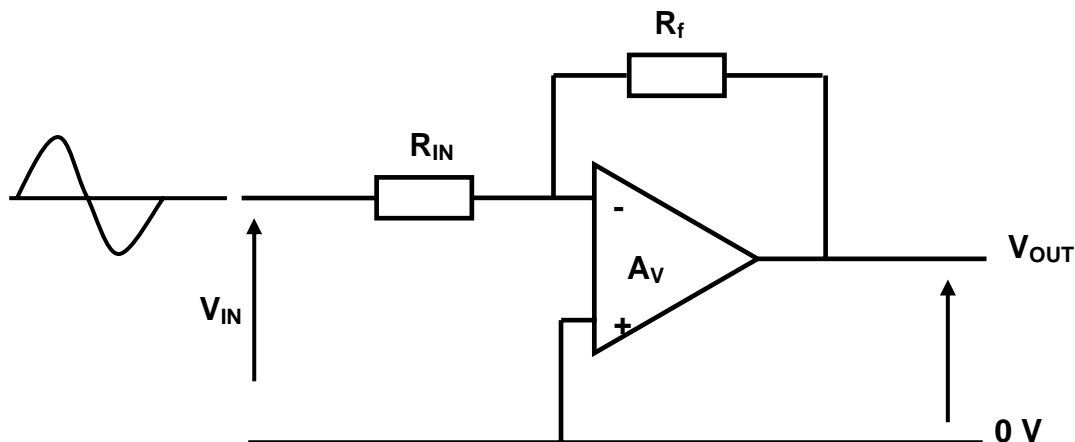

FIGURE 7.2: OP-AMP CIRCUIT

- 7.4.1 Name the circuit above. (1)
- 7.4.2 With the given input signal, draw the output signal and the input signal on the same axis. (2)
- 7.4.3 Describe what will occur to the feedback if the value of R_f is increased. (3)
- 7.4.4 Explain the function of R_{in} . (2)
- 7.4.5 What is common to both the input and output? (1)
- 7.5 State whether an op-amp is a voltage or a current amplifier. (1)
- 7.6 Describe the following terms with reference to the characteristics of an ideal op-amp:
- 7.6.1 Unconditional stability (2)
- 7.6.2 Differential inputs, in other words two inputs (2)
- [25]**

QUESTION 8: THREE-PHASE TRANSFORMERS

- 8.1 Name ONE type of loss in a transformer. (1)
- 8.2 When transmitting power over a long distance, the secondary side of the step-up transformer is connected to the high-tension conductors. Is the secondary connected in star or delta? Explain your answer. (3)
- 8.3 Explain why the core of a transformer is made of laminated plates and not of a solid iron core. (2)

- 8.4 A star-star-connected transformer has 800 turns per phase on its primary windings and 60 turns per phase on its secondary windings. The transformer is connected to an 8 kV supply.

Given:

$$N_P = 800$$

$$N_S = 60$$

$$V_{L(P)} = 8 \text{ kV}$$

Calculate the following:

- 8.4.1 The primary phase voltage (3)
- 8.4.2 The secondary phase voltage (3)
- 8.5 A step-up transformer can step up voltage from a low value to a very high value. Can it step up power? Explain your answer. (3)
[15]

QUESTION 9: LOGIC CONCEPTS AND PLCs

- 9.1 Give TWO examples of the following with reference to PLCs:

- 9.1.1 Inputs (2)
- 9.1.2 Outputs (2)

- 9.2 Name the following ladder diagram symbols:

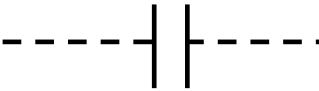
- 9.2.1  (1)

- 9.2.2  (1)

- 9.2.3  (1)

9.3 Answer the questions below with reference to FIGURE 9.1.

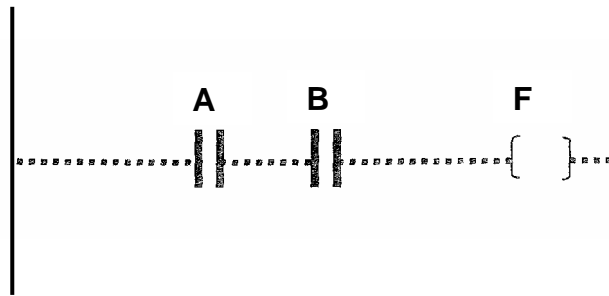

FIGURE 9.1: LADDER DIAGRAM

9.3.1 Name the logic gate that FIGURE 9.1 represents. (1)

9.3.2 Draw the logic symbol of the gate. (2)

9.3.3 Draw a circuit diagram using two switches and a lamp that represents the gate. (4)

9.4 The following operands are used in the programming of PLCs. Give TWO examples of each and give the symbol of each operand:

9.4.1 Timing devices (3)

9.4.2 Counting devices (3)

9.5 Draw the relay control circuit of the ladder logic diagram in FIGURE 9.2 in your ANSWER BOOK.

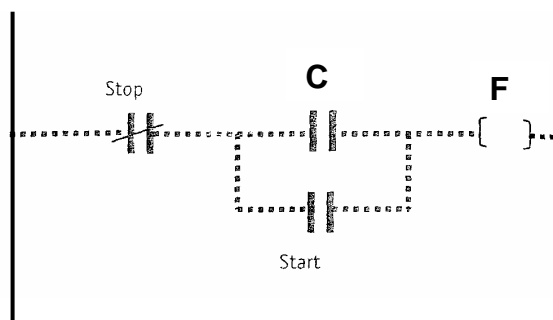

FIGURE 9.2: LADDER LOGIC DIAGRAM OF A STARTER (6)

9.6 With reference to relay control:

9.6.1 Explain why a PLC is more economical. (2)

9.6.2 Explain why a PLC has quicker delivery. (2)

9.6.3 Explain why a PLC requires less maintenance. (2)

9.7 Describe what PLCs are used for and give ONE example. (3)

[35]

QUESTION 10: THREE-PHASE MOTORS AND CONTROL

- 10.1 Name ONE method of cooling three-phase induction motors. (1)
- 10.2 A three-phase delta-connected induction motor draws a current of 20 A from a 380 V/50 Hz supply. The motor is 100% efficient and has a power factor of 0,8 at full load.
- Given:
- $I_L = 20 \text{ A}$
 $V_L = 380 \text{ V}$
 $f = 50 \text{ Hz}$
 $\eta = 100\%$
 $\text{Cos}\theta = 0,8$
- Calculate:
- 10.2.1 The output power of the motor (3)
- 10.2.2 The apparent power of the motor (3)
- 10.2.3 The phase current of the motor (3)
- 10.3 Give THREE possible electrical reasons why a three-phase induction motor will not run when it is started. (3)
- 10.4 Describe ONE electrical inspection that must be done before installing a three-phase motor. (2)
- 10.5 Name THREE losses that occur in three-phase induction motors. (3)
- 10.6 Describe the basic principle of operation of a three-phase induction motor. (7)
- 10.7 Describe the function of a no-volt coil in a three-phase motor starter. (2)
- 10.8 Describe why interlocking contacts are necessary in a three-phase star-delta motor starter. (2)
- 10.9 State how the rotation of a three-phase motor can be reversed. (1)

[30]**TOTAL: 200**

FORMULA SHEET

$$X_L = 2\pi fL$$

$$X_C = \frac{1}{2\pi fC}$$

$$Z = \sqrt{R^2 + (X_L \cong X_C)^2}$$

$$I_T = \sqrt{I_R^2 + (I_C \cong I_L)^2}$$

$$V_T = \sqrt{V_R^2 + (V_C \cong V_L)^2}$$

$$V_R = IR$$

$$V_L = IX_L$$

$$V_C = IX_C$$

$$f_r = \frac{1}{2\pi\sqrt{LC}}$$

$$Q = \frac{1}{R}\sqrt{\frac{L}{C}}$$

$$Q = \frac{X_L}{R} = \frac{V_L}{V_R}$$

$$\cos\theta = \frac{I_R}{I_T}$$

$$\cos\theta = \frac{R}{Z}$$

$$P = VI \cos\theta$$

$$S = VI$$

$$Q = VI \sin\theta$$

} Single phase

$$\left. \begin{aligned} P &= \sqrt{3} V_L I_L \cos\theta \\ S &= \sqrt{3} V_L I_L \\ Q &= \sqrt{3} V_L I_L \sin\theta \end{aligned} \right\} \text{Three phase}$$

$$\left. \begin{aligned} V_L &= V_{Ph} \\ I_L &= \sqrt{3} I_{Ph} \end{aligned} \right\} \text{Delta}$$

$$\left. \begin{aligned} V_L &= \sqrt{3} V_{Ph} \\ I_L &= I_{Ph} \end{aligned} \right\} \text{Star}$$

$$f = \frac{1}{T}$$

$$\frac{V_{ph(P)}}{V_{ph(S)}} = \frac{N_P}{N_S} = \frac{I_{ph(S)}}{I_{ph(P)}}$$

