

SA's Leading Past Year

Exam Paper Portal

STUDY

You have Downloaded, yet Another Great Resource to assist you with your Studies 😊

Thank You for Supporting SA Exam Papers

Your Leading Past Year Exam Paper Resource Portal

Visit us @ www.saexampapers.co.za



SA EXAM
PAPERS



basic education

Department:
Basic Education
REPUBLIC OF SOUTH AFRICA

NATIONAL SENIOR CERTIFICATE

GRADE 12

MECHANICAL TECHNOLOGY

NOVEMBER 2011

MARKS: 200

TIME: 3 hours

**This question paper consists of 19 pages, a 5-page formula sheet and
1 answer sheet.**

INSTRUCTIONS AND INFORMATION

1. Write your centre number and examination number in the spaces provided on the ANSWER BOOK and the ANSWER SHEET.
2. Read ALL the questions carefully.
3. Answer ALL the questions.
4. Answer the questions in QUESTION 1 on the attached ANSWER SHEET. Place the completed ANSWER SHEET in the ANSWER BOOK.
5. Number the answers correctly according to the numbering system used in this question paper.
6. Start EACH question on a NEW page.
7. Show ALL calculations and units. Round off final answers to TWO decimal places.
8. Candidates may use non-programmable scientific calculators and drawing instruments.
9. The value of gravitational force should be taken as 10 m/s^2 .
10. All dimensions are in millimetres, unless stated otherwise in the question.
11. Write neatly and legibly.
12. Use the criteria below to assist you in managing your time.

QUESTION	ASSESSMENT STANDARDS	CONTENT	MARKS	TIME
1	1–9	Multiple-choice Questions	20	18 minutes
2	2	Tools and Equipment	20	18 minutes
3	3	Materials	20	18 minutes
4	1, 4 and 5	Safety, Terminology and Joining Methods	50	45 minutes
5	7 and 9	Maintenance and Turbines	40	36 minutes
6	6 and 8	Forces and Systems and Control	50	45 minutes
TOTAL			200	180 minutes

QUESTION 1: MULTIPLE-CHOICE QUESTIONS

Various options are provided as possible answers to the following questions. Choose the answer and make a cross (X) in the block (A–D) next to the question number (1.1–1.20) on the attached ANSWER SHEET.

EXAMPLE:

1.21	A	B	C	X
------	---	---	---	---

- 1.1 Which ONE of the following safety measures applies to a tensile tester?
- A Apply excessive pressure.
 - B Use a hammer to remove the test piece.
 - C Lower the fluid level.
 - D The work piece should be well secured. (1)
- 1.2 Which ONE of the following safety procedures relates to the bearing and gear puller?
- A Make sure that the legs of the puller are straight.
 - B Make sure that two of the three legs are well secured when pulling.
 - C Oil the contact surfaces.
 - D Use a hammer to assist with the removal of the components. (1)
- 1.3 What is the function of a gas analyser?
- A To analyse inlet gases
 - B To analyse exhaust gases
 - C To analyse smoke
 - D To analyse the air-fuel mixture (1)
- 1.4 What is the function of an inert gas?
- A It keeps the weld cool.
 - B It produces heat.
 - C It allows smooth transfer of metal from the welding wire to the molten weld pool.
 - D It shields the arc and molten weld pool from atmospheric gases. (1)

- 1.5 Raj has to soft solder a bronze pipe fitting. What step of the soldering process is shown in FIGURE 1.1?

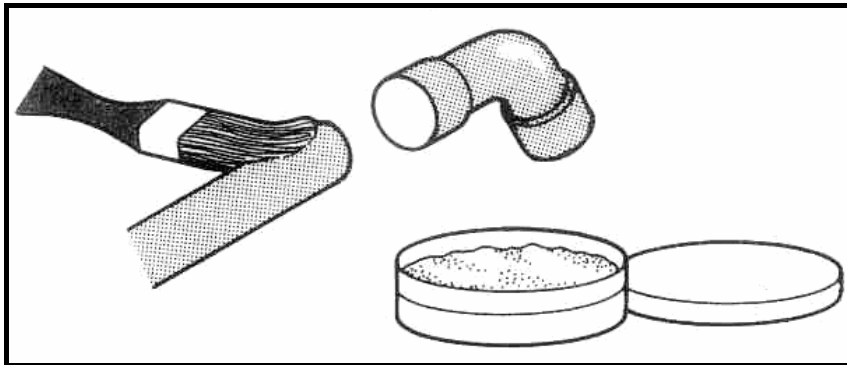

FIGURE 1.1

- A Clean the surface to be joined with steel wool.
B Heat the joint and apply solder to the joint.
C Allow the joint to cool.
D Apply cleaning agent to the surface. (1)
- 1.6 What are *thermosetting plastics*?
- A Materials that form a rigid shape under pressure or heat
B Materials that can be stretched but return to their original shape
C Materials that cannot be reshaped by reheating
D Materials that soften when heated and harden when cooled (1)
- 1.7 Identify the type of milling cutter shown in FIGURE 1.2.

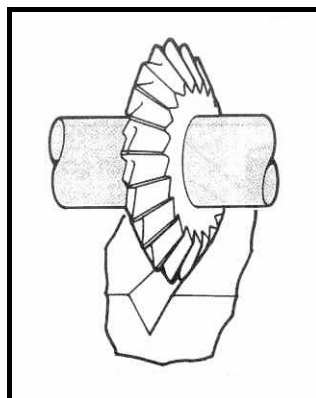

FIGURE 1.2

- A Convex cutter
B Single corner-rounding cutter
C Cylindrical cutter
D Equal-angle cutter (1)

1.8 Which lathe operation is shown in FIGURE 1.3?

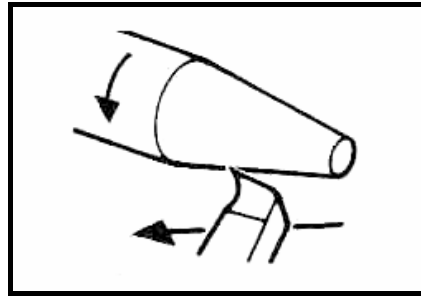

FIGURE 1.3

- A Turning a bar
 - B Turning a taper
 - C Thread cutting
 - D Boring
- (1)

1.9 What is the advantage of up-cut milling?

- A The strain on the arbor and cutter is less.
 - B The finish obtained is finer.
 - C More vibration is expressed.
 - D There is a tendency of the cutter to lift the work piece.
- (1)

1.10 What is the reason for using a free-bend test?

- A To determine the internal quality of the weld
 - B To check the size of the weld
 - C To detect surface flaws
 - D To measure the ductility of the weld deposit
- (1)

1.11 Which ONE of the following is an advantage of a helical cutter?

- A It is easy to manufacture.
 - B It does not require cooling.
 - C The vibration on the machine is less.
 - D It does not require sharpening.
- (1)

1.12 The unit for compressive stress is ...

- A newton.
 - B metre.
 - C pascal.
 - D watt.
- (1)

1.13 What is *Hooke's law*?

- A The measurement of extension or contraction of a bar when an external load is applied
- B The stress value required to produce unit strain in a tensile specimen of a particular material
- C Strain is directly proportional to the stress it causes, provided the limit of proportionality is not exceeded
- D A measurement of the deformation produced by the application of the external forces

(1)

1.14 What is the function of the self-aligning ball bearing shown in FIGURE 1.4?

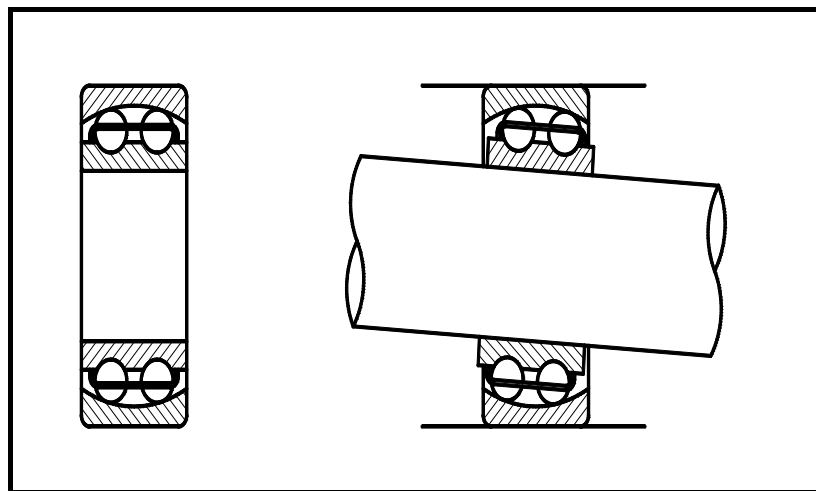

FIGURE 1.4

- A For supporting light radial loads
- B For allowing misalignment between inner and outer grooves
- C For supporting high-pressure loads
- D For carrying a combination of radial and axial thrust loads

(1)

1.15 Which ONE of the following steps should be followed when meshing a rolling chain and a sprocket wheel as shown in FIGURE 1.5?

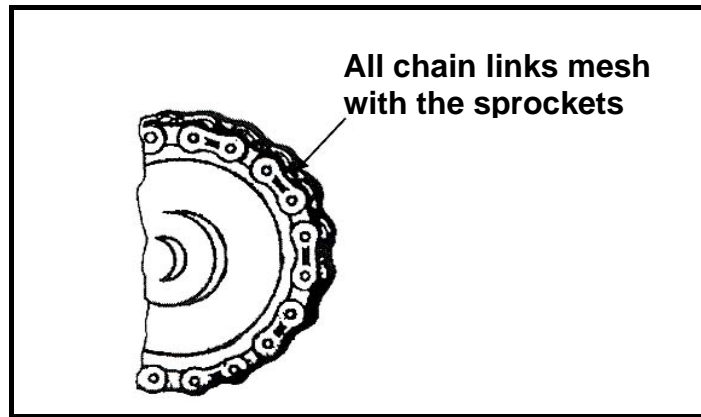

FIGURE 1.5

- A Measure the inside diameter of the sprocket wheel.
- B Compare the teeth sizes with the selection of chains of different sizes.
- C Insert a chain tensioner.
- D Avoid grease on the chain.

(1)

1.16 What distance (X) will the piston move if the crank moves through a distance of 25 mm, as indicated in FIGURE 1.6, and rotates through 180°?

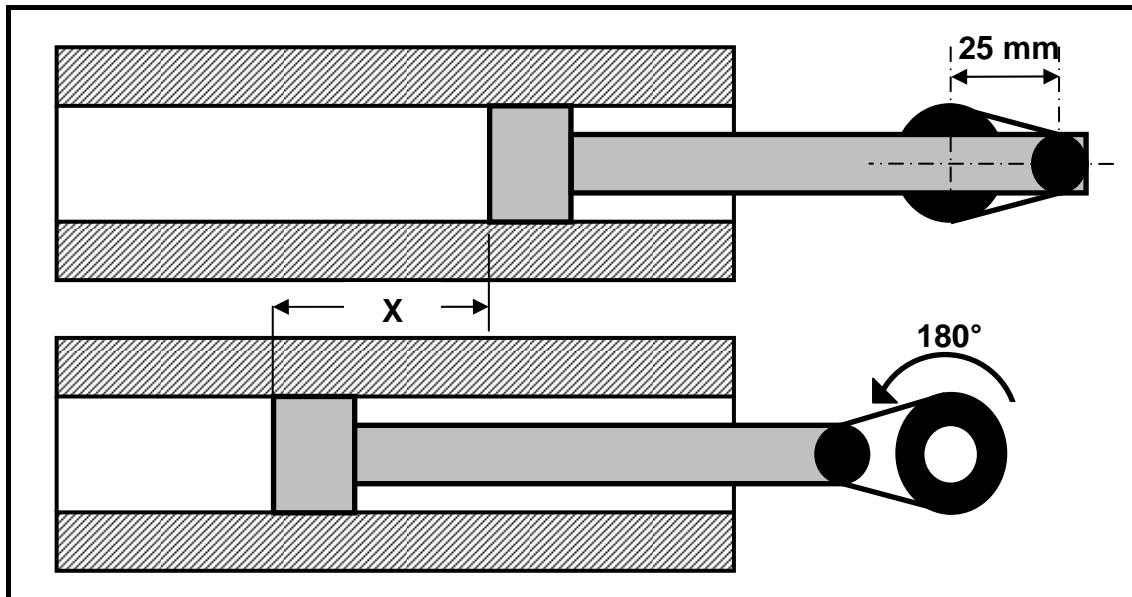

FIGURE 1.6

- A 50 mm
- B 25 mm
- C 12,5 mm
- D 100 mm

(1)

1.17 Identify the type of thread shown in FIGURE 1.7.

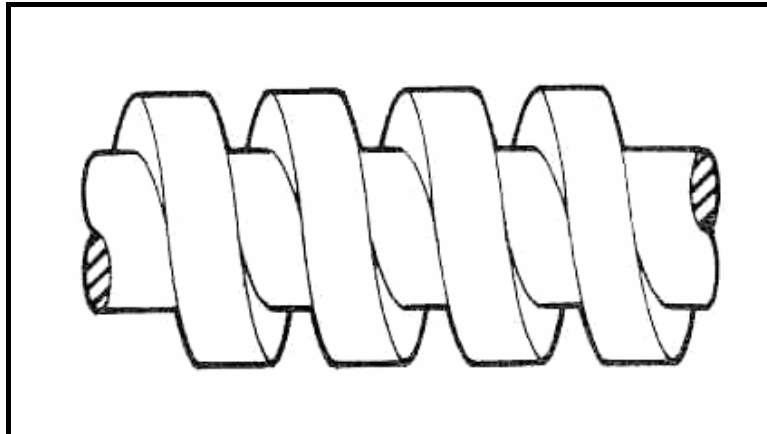

FIGURE 1.7

- A V-screw thread
- B Square screw thread
- C Acme screw thread
- D Trapezium screw thread

(1)

1.18 Define a *cam follower* as shown in FIGURE 1.8.

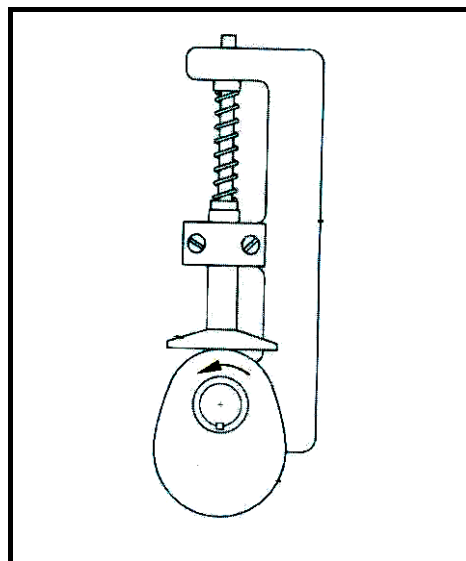

FIGURE 1.8

- A A metal part fixed to an axle
- B A device that rotates on a shaft
- C A device that firmly holds the guide against the cam profile
- D A device designed to move up and down, following the cam

(1)

- 1.19 What is the purpose of the primary function of a turbocharger in an internal combustion engine?
- A To increase the fuel consumption in relation to engine output
 - B To increase the volumetric efficiency of the engine
 - C To decrease the compression pressure of the engine
 - D To decrease the atmospheric pressure of the engine
- (1)
- 1.20 What will the volumetric efficiency be if a 100 mm³ blower displaces 83 mm³ per revolution?
- A 83%
 - B 17%
 - C 103%
 - D 100%
- (1)
[20]

QUESTION 2: TOOLS AND EQUIPMENT

- 2.1 Mr Zama conducted a dry compression test. The test indicated that cylinder number three had a very low reading. After conducting a wet compression test, the reading was the same.
- 2.1.1 Name the next test you will conduct to find the cause for the loss of compression in cylinder number three. (1)
- 2.1.2 Describe, in point form, the test you will conduct in QUESTION 2.1.1. (11)
- 2.2 When assembling the cylinder head, the valve spring must be tested before installation. Give TWO reasons why the valve spring needs to be tested. (2)
- 2.3 What does the abbreviation CNC stand for in terms of lathes and milling machines? (1)
- 2.4 Most welding companies make extensive use of MAGS/MIGS welding equipment for their welding.
- 2.4.1 Name THREE advantages of MAGS/MIGS welding. (3)
- 2.4.2 Name TWO gases used in MAGS/MIGS welding. (2)
- [20]**

QUESTION 3: MATERIALS

- 3.1 Give TWO reasons for using carbon fibre in the manufacture of bicycle frames. (2)
- 3.2 Which of the materials, A or B, shown in FIGURE 3.1 below would be the stiffer of the two if they were subjected to the same force? Give a reason for your answer.

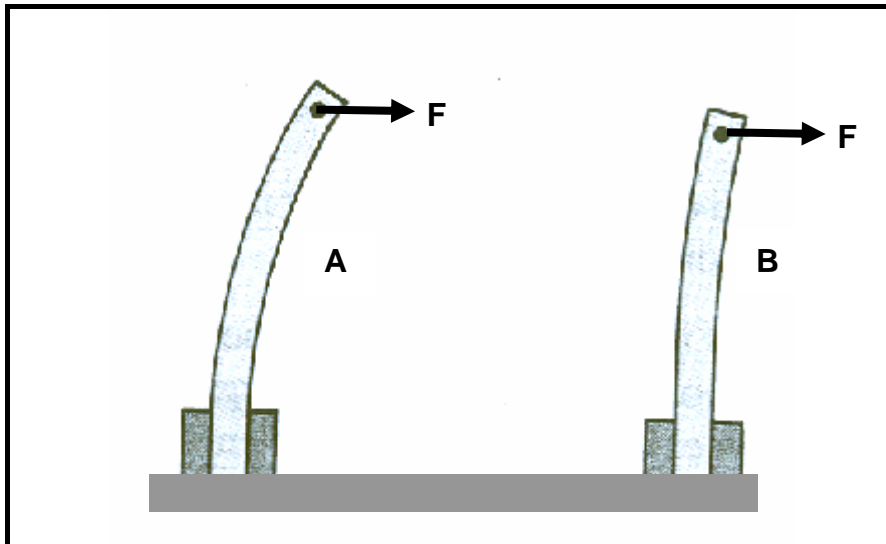
**FIGURE 3.1**

- 3.3 The materials traditionally used in the manufacturing industry are being replaced at an alarming rate by a new generation of materials like non-ferrous alloys. (3)
- 3.3.1 What do you understand by a *non-ferrous alloy*? (2)
- 3.3.2 Name THREE examples of non-ferrous alloys. (3)

3.4 FIGURE 3.2 shows a cross-sectional view of a bush and a part of an aluminium shaft of a model car which is subjected to a low speed. A bush that will ensure low friction and low maintenance needs to be manufactured. No lubrication is allowed.

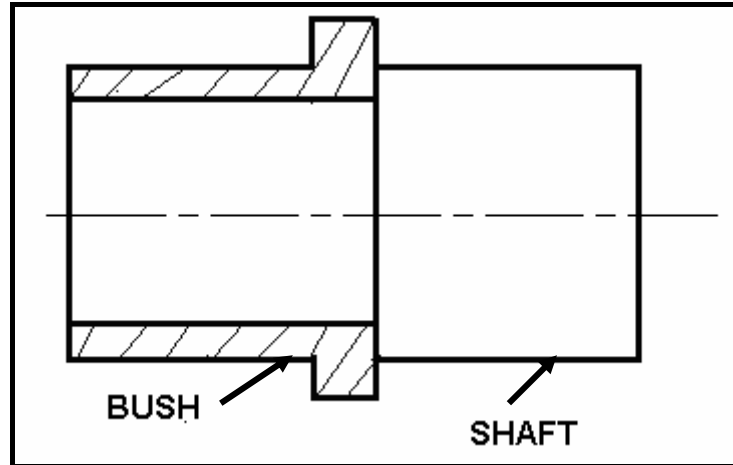

FIGURE 3.2

- 3.4.1 Name TWO possible thermosetting plastics that would be suitable for the bush. (2)
 - 3.4.2 Name FOUR properties applicable to both materials named in QUESTION 3.4.1 to support your choice. (4)
 - 3.5 Name TWO elements used to manufacture soft solder. (2)
 - 3.6 Name TWO properties of silver solder. (2)
- [20]**

QUESTION 4: SAFETY, TERMINOLOGY AND JOINING METHODS

- 4.1 John is using a hydraulic press to fit bearings onto a shaft. State FOUR safety rules for the safe usage of a hydraulic press. (4)
- 4.2 Andy must see to the safe handling and storage of gas cylinders. Which FOUR safety rules must he take into consideration for the safe handling and storage of the gas cylinders? (4)
- 4.3 Calculate the feed in millimetres per minute of a 120 mm diameter cutter with 40 teeth, operating at a cutting speed of 100 metres per minute and a feed of 0,1 mm per tooth. (6)
- 4.4 A spur gear with 67 teeth must be machined onto a work piece. (Hint: Use $N = 70$ divisions or $A = 70$ divisions for the calculations.) The dividing-head ratio is 40 : 1.
- 4.4.1 Calculate the indexing needed for the operation. (5)
- 4.4.2 Calculate the change gears that must be installed onto the dividing head. (5)
- 4.4.3 Name the direction of rotation of the index plate in relation to the index crank. (1)

4.5 A gear train with four gears, gears A, B, C and D, which mesh with each other, are shown in FIGURE 4.1 below. The system is used as a reduction gearbox for an industrial washing machine. Use the information in FIGURE 4.1 to answer the following questions.

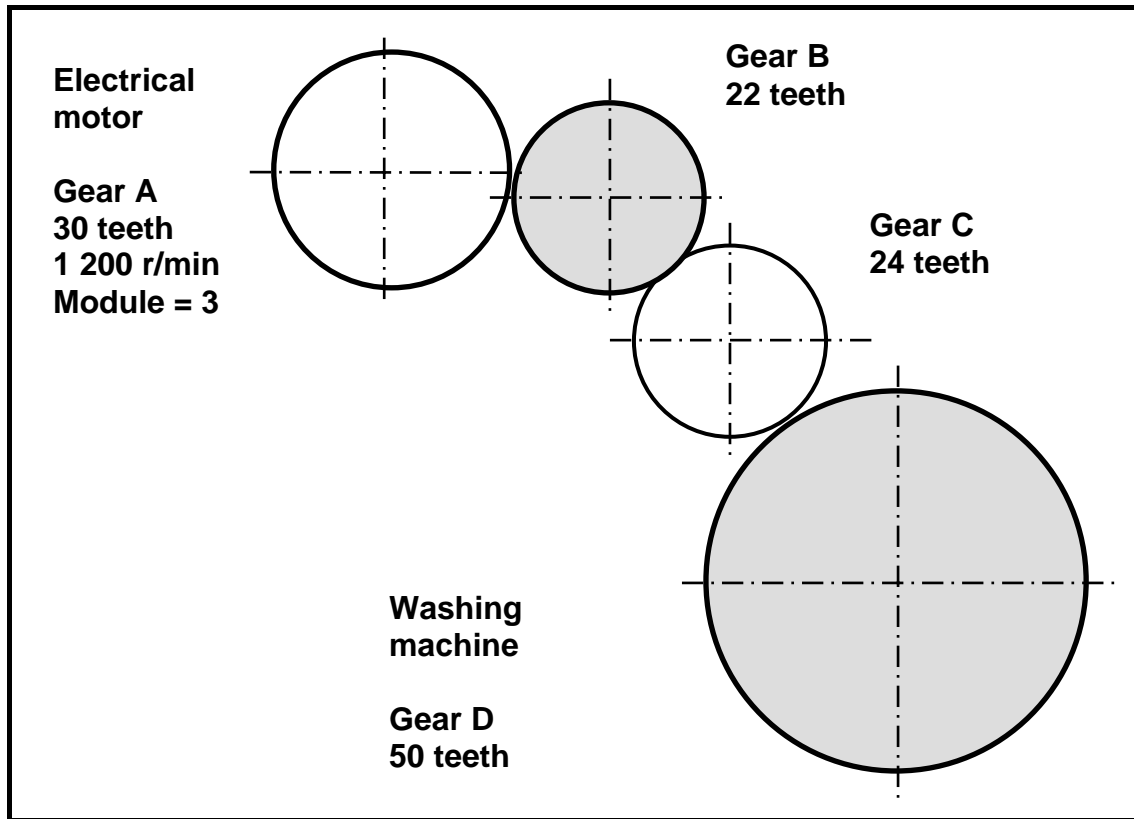

FIGURE 4.1

- 4.5.1 What is gear A known as? (1)
- 4.5.2 What will the direction of rotation of gear C be, if the electrical motor rotates in a clockwise direction? (1)
- 4.5.3 What is gear D known as? (1)
- 4.5.4 Calculate the rotational frequency (N) of gear B. (3)
- 4.5.5 Calculate the pitch-circle diameter (PCD) of gear A. (2)
- 4.5.6 Calculate the outside diameter of gear A. (2)
- 4.5.7 Calculate the dedendum of gear C. (2)

- 4.6 Ben is working for Weldco in the test laboratory. His work is to do weld quality tests on all mild steel products. Help Ben by answering the following questions:
- 4.6.1 Name TWO causes of porosity in a welded joint. (2)
- 4.6.2 Name ONE step that needs to be followed to prevent porosity in a welded joint. (1)
- 4.6.3 Name TWO causes of poor fusion of a welded joint. (2)
- 4.6.4 Name ONE step that needs to be followed to prevent poor fusion of a welded joint. (1)
- 4.6.5 Explain how a liquid dye penetration test is done on a welded joint. (7)
- [50]**

QUESTION 5: MAINTENANCE AND TURBINES

5.1 Lubrication is one of the most important aspects in prolonging the life of mechanical parts.

5.1.1 State FIVE properties of good lubricating oil. (5)

5.1.2 Define the term *viscosity* of oil. (2)

5.1.3 Where will you use EP (extreme pressure) oils? (2)

5.1.4 What does the abbreviation SAE stand for regarding engine oil? (1)

5.1.5 Give FOUR reasons for using cutting fluid. (4)

5.1.6 Choose an item from COLUMN B that matches a term in COLUMN A. Write only the letter (A–D) next to the question number (a–d) in the ANSWER BOOK.

COLUMN A	COLUMN B
(a) Engine	A hydraulic oil
(b) Gearbox	B SAE 20W50
(c) Differential	C soluble oil
(d) Power steering	D extreme pressure oil (EP 90)

(4 x 1) (4)

5.1.7 Name TWO functions of automatic transmission fluid. (2)

5.2 A vehicle's performance output can be increased by using a blower. FIGURE 5.1 shows a type of blower which can be used.

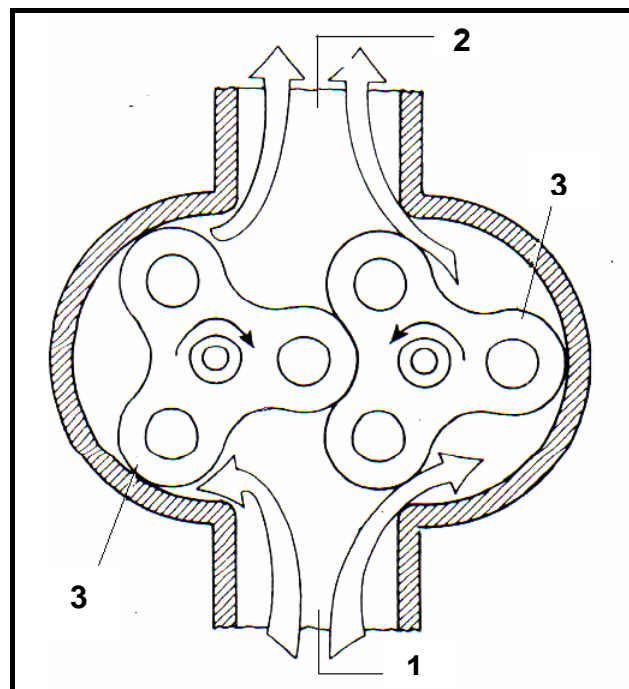
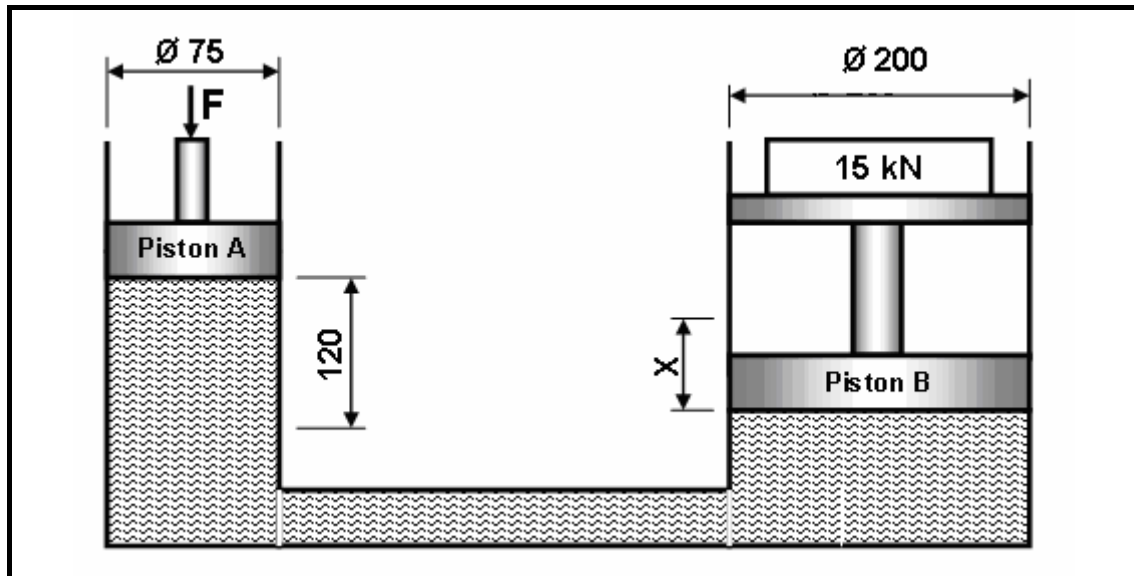

FIGURE 5.1

- 5.2.1 Identify the type of blower shown in FIGURE 5.1. (1)
 - 5.2.2 Label the parts numbered 1 to 3. (3)
 - 5.2.3 Explain the operation of the blower in FIGURE 5.1. (5)
 - 5.3 Give THREE reasons for fitting a supercharger to an engine. (3)
 - 5.4 Which methods are used to drive a supercharger and turbocharger? (2)
 - 5.5 State TWO uses of steam turbines. (2)
 - 5.6 State FOUR advantages of steam turbines. (4)
- [40]**

QUESTION 6: FORCES AND SYSTEMS AND CONTROL

- 6.1 A hydraulic system is being used to put machine parts into position during the assembling process of a machine. The specifications of the system are represented diagrammatically in FIGURE 6.1. Show ALL units.

**FIGURE 6.1**

Determine, by means of calculations, the following:

- 6.1.1 The fluid pressure in the hydraulic system when in equilibrium (6)
- 6.1.2 The force (F) that must be exerted onto piston A to lift the load of 15 kN on piston B (6)
- 6.1.3 The distance X , in millimetres, that piston B will move if piston A completes 16 strokes (6)
- 6.2 A load of 30 kN causes a compressive stress of 6 MPa in a square brass bar. The original length of the bar is 200 mm and Young's modulus for brass is 90 GPa.

Determine, by means of calculations, the following:

- 6.2.1 The side length, in millimetres, of the resistance surface of the square brass bar (8)
- 6.2.2 The strain caused by the load (4)
- 6.2.3 The change in length, in millimetres, caused by the load (3)

6.3 The V-belt drive system of a compressor is shown in FIGURE 6.2. The driver pulley of the belt drive system rotates at 1 440 r/min. The driver pulley has a diameter of 475 mm and the driven pulley has a diameter of 180 mm. The thickness of the belt used in this system is 12 mm.

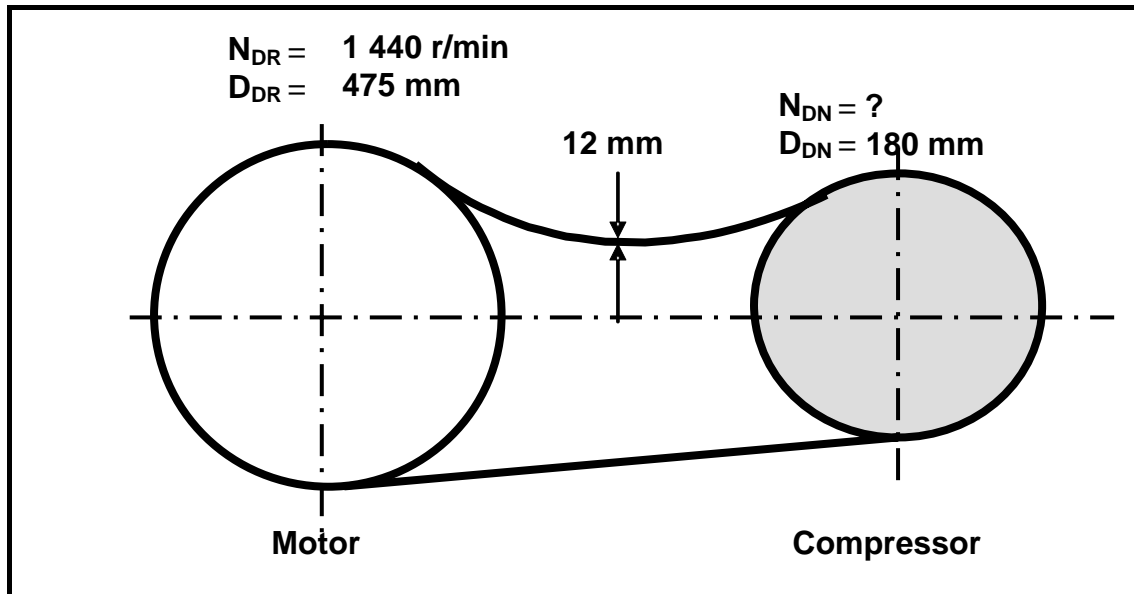

FIGURE 6.2

Determine, by means of calculations, the following:

6.3.1 The rotation frequency of the driven pulley in r/min (5)

6.3.2 The belt speed of the system in metres per second (3)

6.4 A single-plate friction clutch has an effective diameter of 0,28 m. The clutch plate has friction material on both sides. The material has a friction co-efficient of 0,3. The total applied force on the pressure plate is 4 kN.

Calculate and state the correct units for the following:

6.4.1 The maximum torque that can be transmitted (5)

6.4.2 The power transmitted at 3 500 r/min (4)

[50]

TOTAL: 200

FORMULA SHEET FOR MECHANICAL TECHNOLOGY – GRADE 12**1. BELT DRIVES**

$$1.1 \quad \text{Belt speed} = \frac{\pi DN}{60}$$

$$1.2 \quad \text{Belt speed} = \frac{\pi (D+t) \times N}{60} \quad (t = \text{belt thickness})$$

$$1.3 \quad \text{Belt mass} = \text{Area} \times \text{length} \times \text{density} \quad (A = \text{thickness} \times \text{width})$$

$$1.4 \quad \text{Speed ratio} = \frac{\text{Diameter of driven pulley}}{\text{Diameter of driver pulley}}$$

$$1.5 \quad N_1 D_1 = N_2 D_2$$

$$1.6 \quad \text{Open-belt length} = \frac{\pi(D+d)}{2} + \frac{(D-d)^2}{4c} + 2c$$

$$1.7 \quad \text{Crossed-belt length} = \frac{\pi(D+d)}{2} + \frac{(D+d)^2}{4c} + 2c$$

$$1.8 \quad \text{Power (P)} = \frac{2\pi NT}{60}$$

$$1.9 \quad \text{Ratio of tight side to slack side} = \frac{T_1}{T_2}$$

$$1.10 \quad \text{Power (P)} = \frac{(T_1 - T_2) \pi D N}{60} \quad \text{where } T_1 = \text{force in the tight side}$$

$$1.11 \quad \text{Width} = \frac{T_1}{\text{permissible tensile force}}$$

2. FRICTION CLUTCHES

$$2.1 \quad \text{Torque (} T \text{)} = \mu W n R$$

$\mu = \text{coefficient of friction}$
 $W = \text{total force}$
 $n = \text{number of friction surfaces}$
 $R = \text{effective radius}$

$$2.2 \quad \text{Power (} P \text{)} = \frac{2 \pi N T}{60}$$

3. STRESS AND STRAIN

$$3.1 \quad \text{Stress} = \frac{\text{Force}}{\text{Area}} \quad \text{or} \quad \left(\sigma = \frac{F}{A} \right)$$

$$3.2 \quad \text{Strain (} \varepsilon \text{)} = \frac{\text{change in length (} \Delta L \text{)}}{\text{original length (} L \text{)}}$$

$$3.3 \quad \text{Young's modulus (} E \text{)} = \frac{\text{stress}}{\text{strain}} \quad \text{or} \quad \left(\frac{\sigma}{\varepsilon} \right)$$

$$3.4 \quad A_{\text{shaft}} = \frac{\pi d^2}{4}$$

$$3.5 \quad A_{\text{pipe}} = \frac{\pi(D^2 - d^2)}{4}$$

4. HYDRAULICS

$$4.1 \quad \text{Pressure (} P \text{)} = \frac{\text{Force (} F \text{)}}{\text{Area (} A \text{)}}$$

$$4.2 \quad \frac{F_1}{A_1} = \frac{F_2}{A_2}$$

$$4.3 \quad \text{Work done} = \text{force} \times \text{distance}$$

$$4.4 \quad \text{Volume} = \text{Cross-sectional area} \times \text{stroke length (} l \text{ or } s \text{)}$$

5. WHEEL AND AXLE

$$5.1 \quad \text{Velocity ratio (VR)} = \frac{\text{effort distance}}{\text{load distance}} = \frac{2D}{d_2 - d_1}$$

$$5.2 \quad \text{Mechanical advantage (MA)} = \frac{\text{Load (W)}}{\text{Effort (F)}}$$

$$5.3 \quad \text{Mechanical efficiency } (\eta_{\text{mech}}) = \frac{MA}{VR} \times 100\%$$

6. LEVERS

$$6.1 \quad \text{Mechanical advantage (MA)} = \frac{\text{Load (W)}}{\text{Effort (F)}}$$

$$6.2 \quad \text{Input movement (IM)} = \text{Effort} \times \text{distance moved by effort}$$

$$6.3 \quad \text{Output movement (OM)} = \text{Load} \times \text{distance moved by load}$$

$$6.4 \quad \text{Velocity ratio (VR)} = \frac{\text{Input movement}}{\text{Output movement}}$$

7. SCREW THREADS

$$7.1 \quad \text{Pitch diameter} = \text{Outside diameter} - \frac{1}{2} \text{ pitch}$$

$$7.2 \quad \text{Pitch circumference} = \pi \times \text{pitch diameter}$$

$$7.3 \quad \text{Lead} = \text{pitch} \times \text{number of starts}$$

$$7.4 \quad \text{Helix angle: } \tan \theta = \frac{\text{Lead}}{\text{Pitch circumference}}$$

$$7.5 \quad \text{Leading tool angle} = 90^\circ - (\text{helix angle} + \text{clearance angle})$$

$$7.6 \quad \text{Following/Trailing angle} = 90^\circ + (\text{helix angle} - \text{clearance angle})$$

$$7.7 \quad \text{Number of turns} = \frac{\text{height}}{\text{lead}}$$

8. GEAR DRIVES

$$8.1 \quad \text{Power (} P \text{)} = \frac{2 \pi NT}{60}$$

$$8.2 \quad \text{Gear ratio} = \frac{\text{Product of the number of teeth on driven gears}}{\text{Product of the number of teeth on driving gears}}$$

$$8.3 \quad \frac{N_{\text{input}}}{N_{\text{output}}} = \frac{\text{Product of the number of teeth on driven gears}}{\text{Product of the number of teeth on driving gears}}$$

$$8.4 \quad \text{Torque} = \text{force} \times \text{radius}$$

$$8.5 \quad \text{Torque transmitted} = \text{gear ratio} \times \text{input torque}$$

$$8.6 \quad \text{Module (} m \text{)} = \frac{\text{Pitch-circle diameter (PCD)}}{\text{Number of teeth (} T \text{)}}$$

$$8.7 \quad N_1 T_1 = N_2 T_2$$

$$8.8 \quad \text{Pitch-circle diameter (PCD)} = \frac{\text{circular pitch (CP)} \times \text{number of teeth (} T \text{)}}{\pi}$$

$$8.9 \quad \text{Outside diameter (OD)} = \text{PCD} + 2 \text{ module}$$

$$8.10 \quad \text{Addendum (} a \text{)} = \text{module (} m \text{)}$$

$$8.11 \quad \text{Dedendum (} b \text{)} = 1,157 m \quad \text{or} \quad \text{Dedendum (} b \text{)} = 1,25 m$$

$$8.12 \quad \text{Cutting depth (} h \text{)} = 2,157 m \quad \text{or} \quad \text{Cutting depth (} h \text{)} = 2,25 m$$

$$8.13 \quad \text{Clearance (} c \text{)} = 0,157 m \quad \text{or} \quad \text{Clearance (} c \text{)} = 0,25 m$$

$$8.14 \quad \text{Circular pitch (CP)} = m \times \pi$$

9. CINCINNATI DIVIDING HEAD TABLE FOR THE MILLING MACHINE

<i>Hole circles</i>											
<i>Side 1</i>	24	25	28	30	34	37	38	39	41	42	43
<i>Side 2</i>	46	47	49	51	53	54	57	58	59	62	66

<i>Standard change gears</i>										
24 x 2	28	32	40	44	48	56	64	72	86	100

$$9.1 \quad \text{Simple indexing} = \frac{40}{n} \quad (\text{where } n = \text{number of divisions})$$

9.2 *Change gears:*

$$\frac{Dr}{Dv} = (A - n) \times \frac{40}{A} \quad \text{or} \quad \frac{Dr}{Dv} = \frac{(A - n)}{A} \times \frac{40}{1} \quad \text{or} \quad \frac{Dr}{Dv} = (N - n) \times \frac{40}{N}$$

10. CALCULATIONS OF FEED

$$10.1 \quad \text{Feed } (f) = f_1 \times T \times N$$

Where: f = feed in millimetres per minute

f₁ = feed per tooth in millimetres

T = number of teeth on cutter

N = number of revolutions of cutter per minute

$$10.2 \quad \text{Cutting speed } (V) = \pi \times D \times N$$

Where: D = diameter of the cutter in metres

ANSWER SHEET**CENTRE NUMBER:**

--	--	--	--	--	--	--	--	--

EXAMINATION NUMBER:

--	--	--	--	--	--	--	--	--	--	--	--	--	--

QUESTION 1: MULTIPLE-CHOICE QUESTIONS

1.1	A	B	C	D
-----	---	---	---	---

1.2	A	B	C	D
-----	---	---	---	---

1.3	A	B	C	D
-----	---	---	---	---

1.4	A	B	C	D
-----	---	---	---	---

1.5	A	B	C	D
-----	---	---	---	---

1.6	A	B	C	D
-----	---	---	---	---

1.7	A	B	C	D
-----	---	---	---	---

1.8	A	B	C	D
-----	---	---	---	---

1.9	A	B	C	D
-----	---	---	---	---

1.10	A	B	C	D
------	---	---	---	---

1.11	A	B	C	D
------	---	---	---	---

1.12	A	B	C	D
------	---	---	---	---

1.13	A	B	C	D
------	---	---	---	---

1.14	A	B	C	D
------	---	---	---	---

1.15	A	B	C	D
------	---	---	---	---

1.16	A	B	C	D
------	---	---	---	---

1.17	A	B	C	D
------	---	---	---	---

1.18	A	B	C	D
------	---	---	---	---

1.19	A	B	C	D
------	---	---	---	---

1.20	A	B	C	D
------	---	---	---	---

[20]