

SA's Leading Past Year

Exam Paper Portal

STUDY

You have Downloaded, yet Another Great Resource to assist you with your Studies 😊

Thank You for Supporting SA Exam Papers

Your Leading Past Year Exam Paper Resource Portal

Visit us @ www.saexampapers.co.za



SA EXAM
PAPERS



basic education

Department:
Basic Education
REPUBLIC OF SOUTH AFRICA

SENIOR CERTIFICATE EXAMINATIONS/ NATIONAL SENIOR CERTIFICATE EXAMINATIONS

LIFE SCIENCES P2

2022

MARKS: 150

TIME: 2½ hours



This question paper consists of 15 pages.

INSTRUCTIONS AND INFORMATION

Read the following instructions carefully before answering the questions.

1. Answer ALL the questions.
2. Write ALL the answers in the ANSWER BOOK.
3. Start the answers to EACH question at the top of a NEW page.
4. Number the answers correctly according to the numbering system used in this question paper.
5. Present your answers according to the instructions of each question.
6. Do ALL drawings in pencil and label them in blue or black ink.
7. Draw diagrams, tables or flow charts only when asked to do so.
8. The diagrams in this question paper are NOT necessarily drawn to scale.
9. Do NOT use graph paper.
10. You must use a non-programmable calculator, protractor and a compass, where necessary.
11. Write neatly and legibly.



SECTION A**QUESTION 1**

1.1 Various options are provided as possible answers to the following questions. Choose the answer and write only the letter (A to D) next to the question number (1.1.1 to 1.1.10) in the ANSWER BOOK, e.g. 1.1.11 D.

1.1.1 The components of a DNA molecule that provide the code for protein synthesis are the ...

- A sugars.
- B phosphates.
- C hydrogen bonds.
- D nitrogenous bases.

1.1.2 During which stage of meiosis do spindle fibres begin to form?

- A Prophase
- B Metaphase
- C Anaphase
- D Telophase

1.1.3 An individual has Down syndrome. In the karyotype there is an abnormal number of chromosomes at chromosome pair ...

- A 13.
- B 18.
- C 21.
- D 23.

1.1.4 An individual that has received an identical allele from each parent is described as being ...

- A homologous.
- B dominant.
- C homozygous.
- D heterozygous.

1.1.5 A plant species has a diploid chromosome number of 12.

Which ONE of the following is the haploid chromosome number for this species?

- A 24
- B 12
- C 6
- D 36



- 1.1.6 Inheritance by *multiple alleles* in genetics refers to ...
- A two alleles that influence two characteristics.
 - B more than two alleles that influence one characteristic.
 - C one allele that influences more than one characteristic.
 - D more than two alleles that influence two characteristics.
- 1.1.7 Which ONE of the following is a reproductive isolation mechanism?
- A Breeding at the same time of the year
 - B Infertile offspring
 - C Plant adaptation to the same pollinators
 - D Improved fertilisation
- 1.1.8 Normal human ova have ...
- A 22 autosomes and an X chromosome.
 - B 23 autosomes and an X chromosome.
 - C 22 autosomes and a Y chromosome.
 - D 23 autosomes and a Y chromosome.
- 1.1.9 Which ONE of the following occurs in mitosis but NOT in meiosis?
- A Two cells are formed at the end of the division
 - B Crossing over takes place
 - C Homologous chromosomes arrange at the equator
 - D Centrioles form at the poles of the cell



1.1.10 The graph below shows the percentage similarity between human (Hu) DNA and the DNA of some species of African apes.

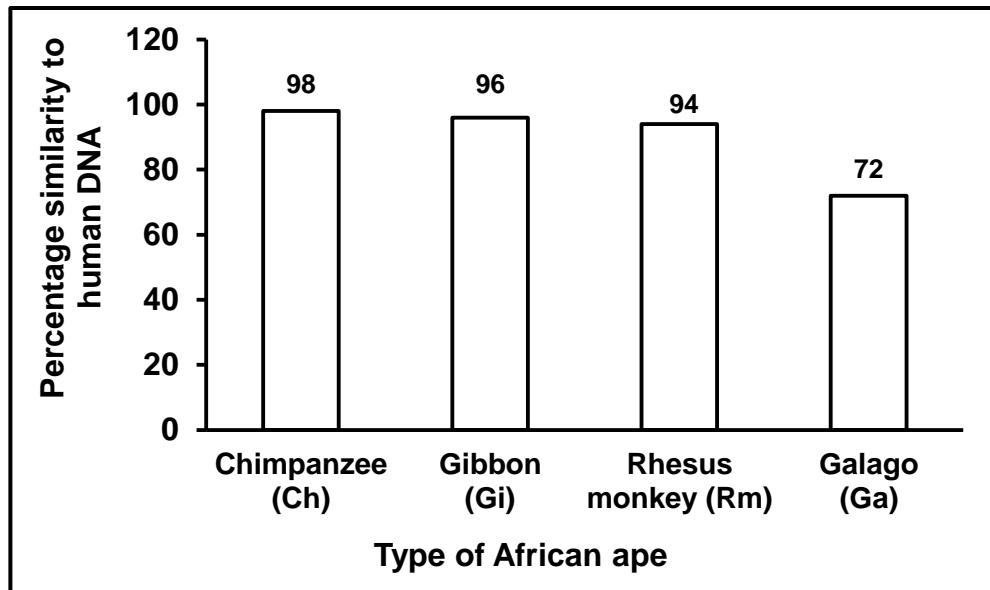

Which ONE of the following phylogenetic trees best represents the information in the graph?

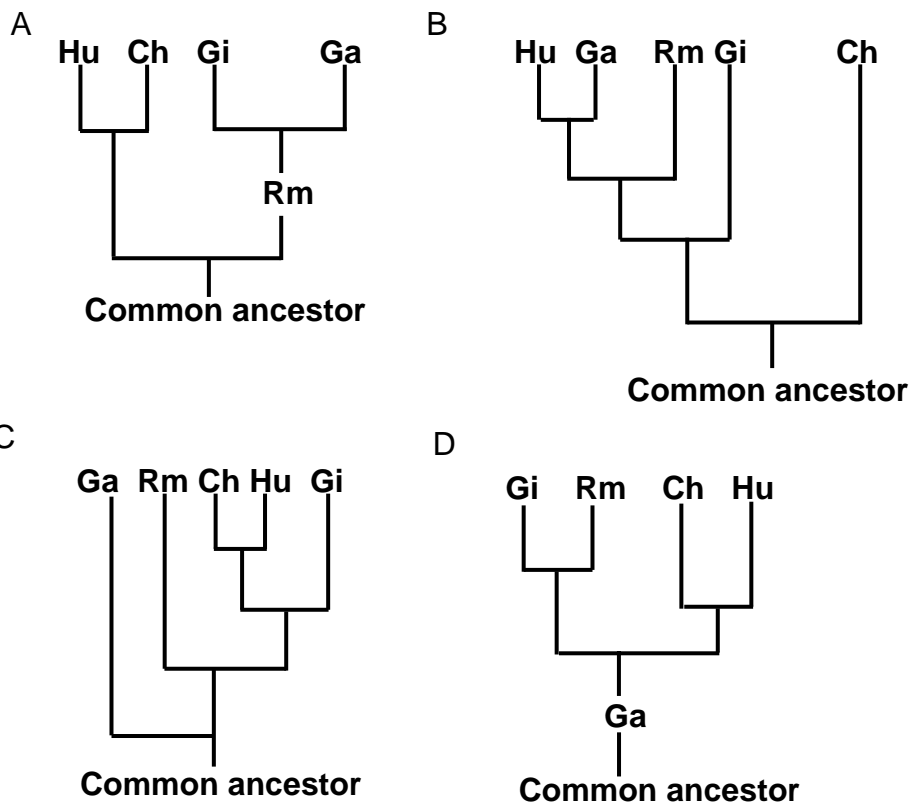

(10 x 2) (20)



1.2 Give the correct **biological term** for each of the following descriptions. Write only the term next to the question numbers (1.2.1 to 1.2.10) in the ANSWER BOOK.

- 1.2.1 Division of the cytoplasm of a cell during meiosis
- 1.2.2 The sugar molecule present in a nucleotide of RNA
- 1.2.3 The position of a gene on a chromosome
- 1.2.4 The process during which a DNA molecule makes an exact copy of itself
- 1.2.5 Undifferentiated cells that may be stimulated to develop into any type of body cell
- 1.2.6 Mendel's principle which states that an organism possesses two factors which separate so that each gamete contains only one of these factors
- 1.2.7 The evolutionary theory that proposes long periods where species do not change, alternating with short periods where rapid changes occur
- 1.2.8 A tangled network of DNA and protein located within the nucleus
- 1.2.9 The natural shape of the DNA molecule
- 1.2.10 The phase in the cell cycle during which cell growth occurs

(10 x 1) **(10)**

1.3 Indicate whether each of the statements in COLUMN I apply to **A ONLY**, **B ONLY**, **BOTH A AND B** or **NONE** of the items in COLUMN II. Write **A only**, **B only**, **both A and B**, or **none** next to the question numbers (1.3.1 to 1.3.3) in the ANSWER BOOK.

COLUMN I	COLUMN II
1.3.1 A group of similar organisms that occurs in a particular place at a particular time with the ability to interbreed	A: Population B: Species
1.3.2 The manipulation of biological processes to satisfy human needs	A: Biogeography B: Biotechnology
1.3.3 Discovered the structure of the DNA molecule	A: Francis Crick B: James Watson

(3 x 2) **(6)**



- 1.4 In tomato plants, tall stems (**T**) are dominant over short stems (**t**) and red fruit (**R**) is dominant over yellow fruit (**r**).

A farmer crosses a homozygous tall, yellow tomato plant with a plant that is heterozygous for both characteristics.

- 1.4.1 Name this type of genetic cross. (1)
- 1.4.2 Give the genotype of a homozygous tall, yellow tomato plant. (2)
- 1.4.3 List the genotypes of ALL the possible gametes for a plant that is heterozygous for both characteristics. (4)
(7)

- 1.5 Haemophilia is a sex-linked recessive trait (**X^h**). The pedigree diagram below shows the inheritance of haemophilia in a family.

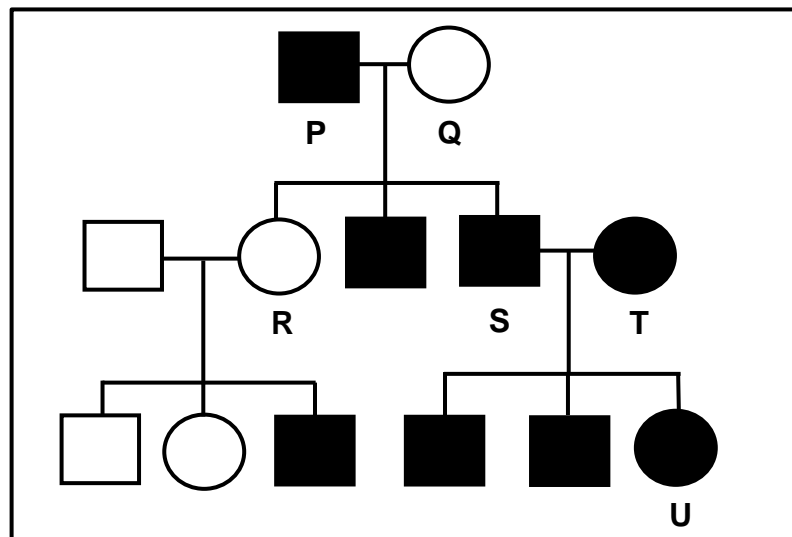

- 1.5.1 State what is represented by the squares on a pedigree diagram. (1)
- 1.5.2 State the number of:
- (a) Generations represented in this pedigree diagram (1)
- (b) Offspring of individuals **P** and **Q** (1)
- 1.5.3 Give the:
- (a) LETTERS only, of females who have haemophilia (2)
- (b) Genotype of individual **R** (2)
(7)

TOTAL SECTION A: [50]



SECTION B**QUESTION 2**

2.1 The diagram below represents one cell in a phase of meiosis.

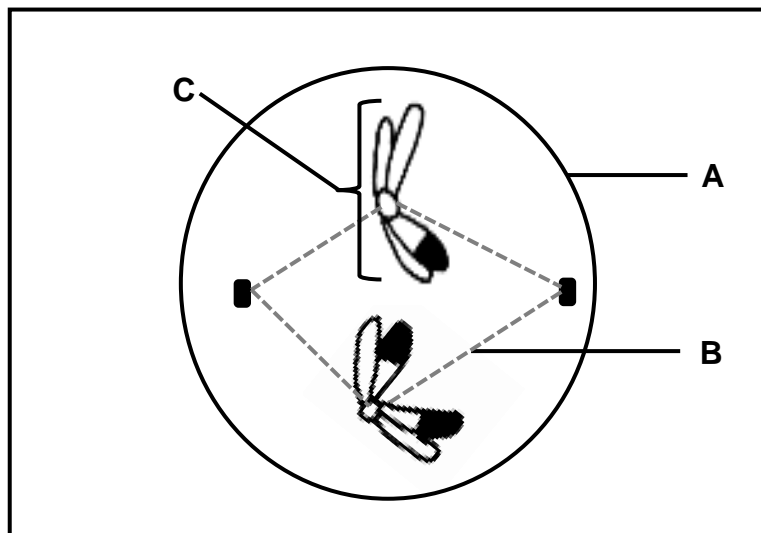

- 2.1.1 Identify the phase of meiosis shown. (1)
- 2.1.2 Give ONE observable reason for your answer to QUESTION 2.1.1. (2)
- 2.1.3 Identify structure:
- (a) **A** (1)
- (b) **B** (1)
- 2.1.4 Describe the role of part **B** in the movement of chromosomes during meiosis. (2)
- 2.1.5 Draw a labelled diagram of structure **C** as it would appear in the final phase of this meiotic division. Show the correct shading. (4)
- (11)**



2.2 The diagram below represents the process of protein synthesis in a cell.

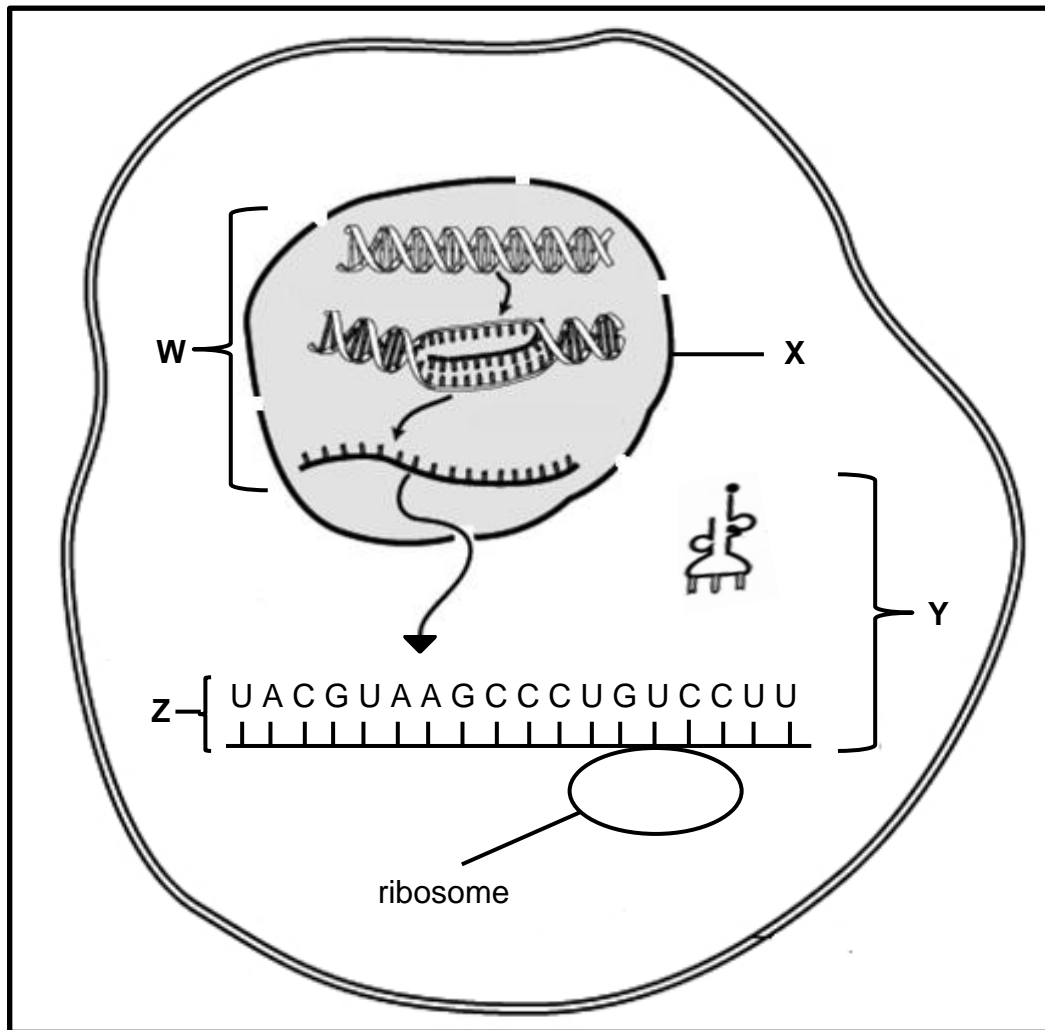

2.2.1 Name the process which occurs at:

(a) **W** (1)

(b) **Y** (1)

2.2.2 Identify:

(a) Organelle **X** (1)

(b) Molecule **Z** (1)

2.2.3 State TWO locations of DNA in a cell, other than in the nucleus. (2)

2.2.4 Describe the process at **W**. (7)



The table below shows some tRNA anticodons with their corresponding amino acids.

tRNA ANTICODON	AMINO ACID
CAG	Valine
GAA	Leucine
AUG	Tyrosine
GGA	Proline
UCG	Serine
CAU	Valine

2.2.5 Name the:

- (a) DNA base triplet that codes for serine (1)
- (b) First TWO amino acids coded for by molecule **Z** in the diagram (the molecule is read from left to right) (2)

2.2.6 What is the change in the sequence of nitrogenous bases in a DNA molecule called? (1)

2.2.7 The codon CUU (last codon) on molecule **Z** changed to CCU.

Explain the effect it would have on this particular protein molecule. (3)
(20)



2.3 A family wanted to identify the biological father of a boy. The mother of the boy is known. Blood groups and DNA profiles of the mother, the boy and two males were used to determine paternity.

The data below shows the results of the two procedures.

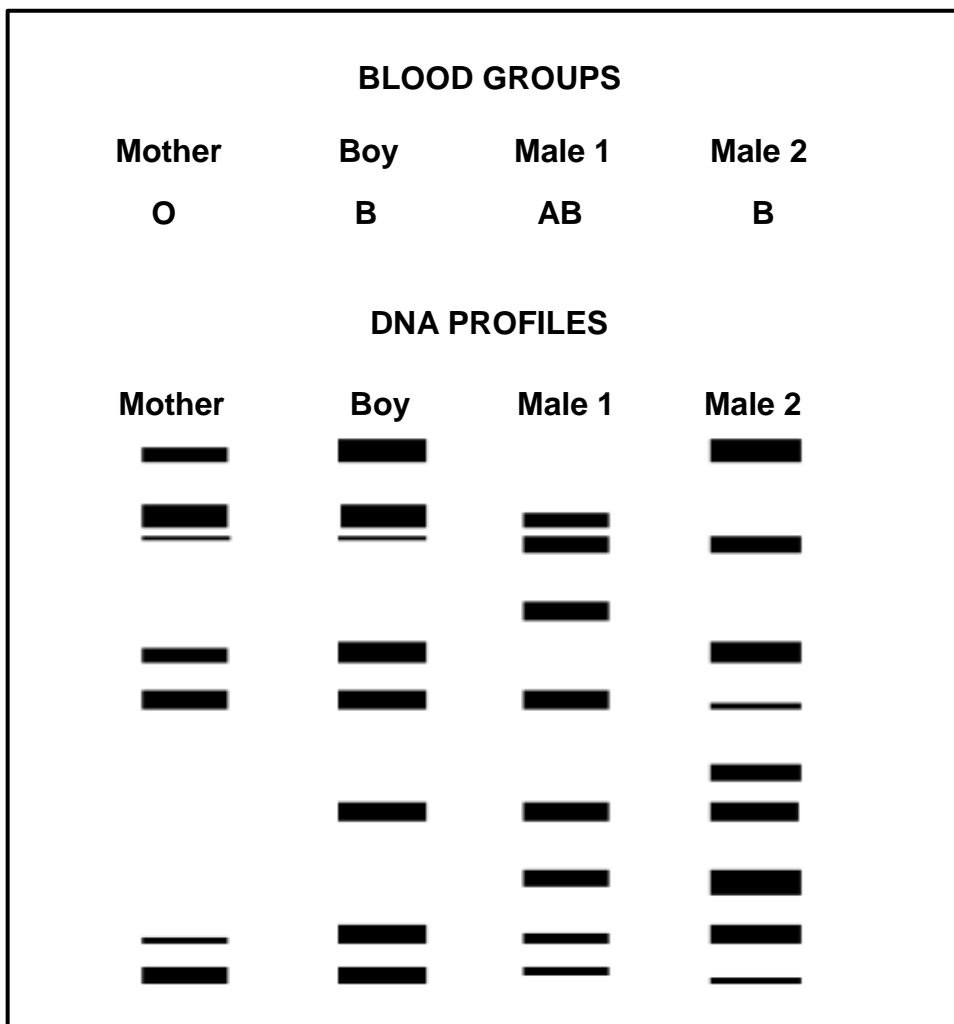

- 2.3.1 Explain why paternity of the boy could not be established using blood groups only. (5)
 - 2.3.2 Who is the biological father of the boy according to the DNA profiles? (1)
 - 2.3.3 Explain your answer to QUESTION 2.3.2. (3)
 - 2.3.4 State ONE other use of DNA profiling. (1)
- (10)**



- 2.4 The diagram below shows the inheritance of flower colour in snapdragon plants.

The two alleles controlling flower colour are red (**R**) and white (**W**).

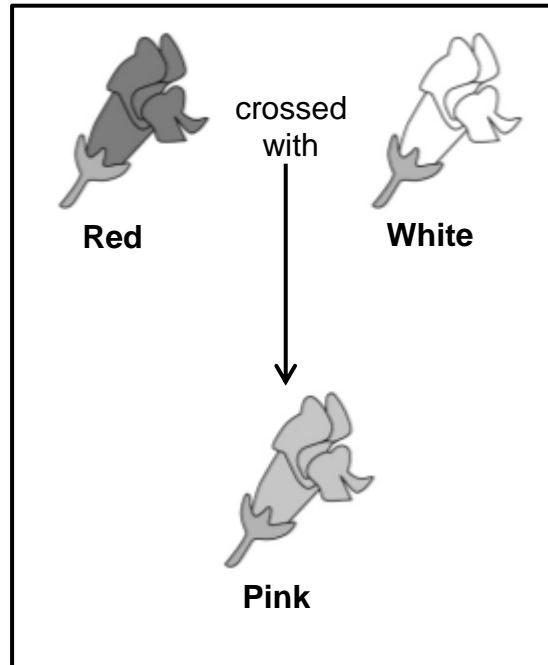

- 2.4.1 State the type of dominance shown by the snapdragon plants. (1)
- 2.4.2 Give a reason for your answer to QUESTION 2.4.1. (2)
- 2.4.3 A gardener crossed two pink-flowered snapdragon plants.

Use a genetic cross to show the ratio of the expected phenotypes in the offspring.

(6)
(9)
[50]



QUESTION 3

- 3.1 Diagrams **A** and **B** show the ventral (bottom) view of the skulls of two organisms. The diagrams are NOT drawn to scale.

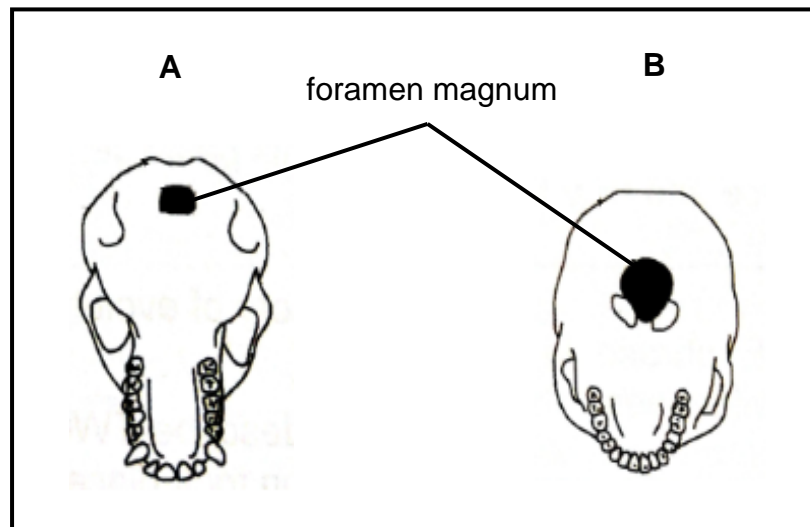

- 3.1.1 Which diagram represents the skull of a bipedal organism? (1)
- 3.1.2 Give ONE visible reason for your answer to QUESTION 3.1.1. (2)
- 3.1.3 Tabulate TWO visible differences between the upper jaws in diagrams **A** and **B** that represent trends in human evolution. (5)
- 3.1.4 Explain the significance of the shape of the spine that is associated with the skull in diagram **B**. (2)
- (10)**



- 3.2 The herbicide glyphosate is used to control weeds in maize fields. The herbicide kills the weeds, but it can also kill the maize plants. It has been found that some weeds developed resistance to glyphosate treatment.

Scientists carried out an investigation to determine the development of glyphosate resistance in the weeds. The weeds were treated with the same concentration of glyphosate each year from 2009 to 2016 and the percentage of glyphosate resistant weeds in the field was recorded every year.

The results are shown in the table below.

YEAR	GLYPHOSATE RESISTANT WEEDS (%)
2009	10
2010	20
2011	32
2012	42
2013	53
2014	58
2015	65
2016	65

- 3.2.1 Describe the change in glyphosate resistance over the time of the investigation. (3)
- 3.2.2 Calculate the percentage increase in glyphosate resistant weeds from 2010 to 2015. Show ALL your working. (3)
- 3.2.3 Scientists isolated the gene for glyphosate resistance from the weeds and used it to genetically modify the maize plants.
Explain the economic benefit of making the maize plants resistant to glyphosate. (3)
- 3.2.4 Draw a bar graph to illustrate the results of the investigation in the first four years. (6)
- (15)**



- 3.3 A population of lizards on an island, Island **A**, were well suited to feed mainly on insects. Scientists moved five adult pairs of this lizard species to a neighbouring island, Island **B**. Here they reproduced and a new population formed. Island **B** has a large supply of plants with tough fibrous leaves and fewer insects. Exposure to this new environment may have caused the lizards to undergo evolution.

Thirty-six years later, scientists returned to Island **B** to conduct further investigations on the lizard population there. They observed that the jaw size of the lizards had increased. Scientists also analysed the stomach content of the lizards and found that it was mainly plant-based. They also confirmed that the two populations still belong to the same species.

- 3.3.1 Describe how the scientists could confirm that there was a change in jaw size between the lizards of Island **A** and the lizards of Island **B**. (3)
- 3.3.2 Explain how the larger jaws of the lizards on Island **B** would be structurally suited to eat tough fibrous leaves. (3)
- 3.3.3 How did the scientists determine that the two populations of lizards on both islands still belong to the same species? (2)
- 3.3.4 Explain the possible effect that the evolution of the lizards has on biodiversity. (2)
- 3.3.5 Use Darwin's theory of natural selection to explain the evolution of lizards with larger jaws. (7)
- (17)**

- 3.4 The 'Out of Africa' hypothesis is one explanation of the evolution of modern humans.

- 3.4.1 State the 'Out of Africa' hypothesis. (2)
- 3.4.2 Name the family to which modern humans belong. (1)
- 3.4.3 What genetic evidence is used to support the 'Out of Africa' hypothesis? (1)
- 3.4.4 Describe how fossil evidence is used to support the 'Out of Africa' hypothesis. (4)
- (8)**
[50]

TOTAL SECTION B: 100
GRAND TOTAL: 150

