

SA's Leading Past Year

Exam Paper Portal

STUDY

You have Downloaded, yet Another Great Resource to assist you with your Studies 😊

Thank You for Supporting SA Exam Papers

Your Leading Past Year Exam Paper Resource Portal

Visit us @ www.saexampapers.co.za



SA EXAM
PAPERS



KWAZULU-NATAL PROVINCE

**EDUCATION
REPUBLIC OF SOUTH AFRICA**

NATIONAL SENIOR CERTIFICATE

GRADE 12

**LIFE SCIENCES P2
PREPARATORY EXAMINATION
SEPTEMBER 2022**

MARKS: 150

TIME: 2½ hours

This question paper consists of 16 pages.

INSTRUCTIONS AND INFORMATION

Read the following instructions carefully before answering the questions.

1. Answer ALL the questions.
2. Write ALL the answers in the ANSWER BOOK.
3. Start the answers to each question at the top of a NEW page.
4. Number the answers correctly according to the numbering system used in this question paper.
5. Present your answers according to the instructions of each question.
6. Do ALL drawings in pencil and label them in blue or black ink.
7. Draw diagrams, tables or flow charts only when asked to do so.
8. The diagrams in this question paper are NOT necessarily drawn to scale.
9. Do NOT use graph paper.
10. You may use a non-programmable calculator, protractor and a compass.
11. Write neatly and legibly.

SECTION A**QUESTION 1**

1.1 Various options are provided as possible answers to the following questions. Choose the answer and write only the letter (A to D) next to the question number (1.1.1 to 1.1.10) in the ANSWER BOOK, for example 1.1.11 D.

1.1.1 Which ONE of the following structures in an animal cell contains DNA?

- A Centrosome
- B Ribosome
- C Mitochondrion
- D Centriole

1.1.2 A sequence of nitrogenous bases on a DNA molecule that codes for a specific characteristic is called a ...

- A gene.
- B locus.
- C karyotype.
- D genome.

1.1.3 Which ONE of the following describes evolution, where there are long periods of time where species do not change alternating with short periods where rapid changes occur?

- A Natural selection
- B Punctuated equilibrium
- C Mutation
- D Speciation

1.1.4 Below is a list of fossils discovered in South Africa.

- (i) Karabo
- (ii) Taung child
- (iii) Mrs Ples
- (iv) Little foot

Which ONE of the following combinations of fossils is classified in the genus *Australopithecus*?

- A (i), (ii) and (iii) only
- B (i) and (ii) only
- C (ii), (iii) and (iv) only
- D (i), (ii), (iii) and (iv)

1.1.5 The reproductive isolation mechanisms that help to keep species separate, include the ...

- A plant adaptation to same pollinators.
- B prevention of fertilisation.
- C species breeding at the same time of the year.
- D species producing fertile offspring.

1.1.6 The diagram below represents part of a DNA molecule.

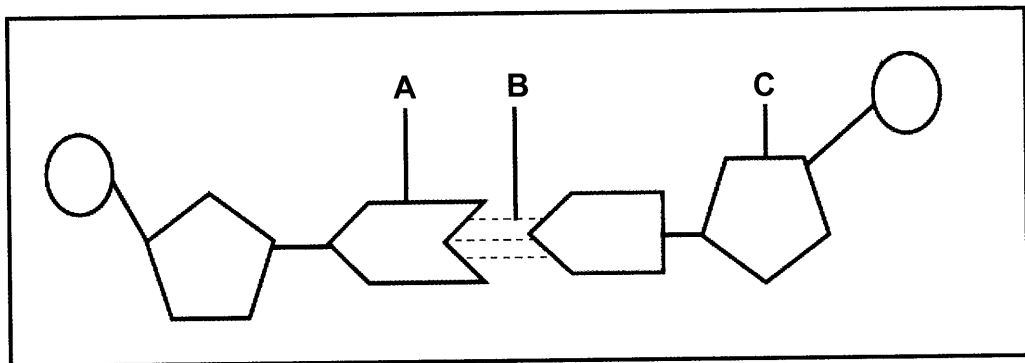

The correct labels for parts **A**, **B** and **C** respectively are ...

- A nitrogenous base, hydrogen bond, deoxyribose sugar.
- B nitrogenous base, hydrogen bond and ribose sugar.
- C nitrogenous base, hydrogen bond and phosphate.
- D nitrogenous base, peptide bond and deoxyribose sugar.

1.1.7 Farmers prefer to produce red roses. The allele for red is **R** and the allele for white is **W**.

Which ONE of the following crosses would give the highest proportion of red roses?

- A WW x RW
- B RR x WW
- C RW x RW
- D RR x RW

1.1.8 Which ONE of the following may result in Down syndrome in humans?

- A Failure of the gonosomes to separate during meiosis I
- B A gene mutation on chromosome 21
- C A recessive allele on the X chromosome
- D Failure of chromosome pair 21 to separate during anaphase I

1.1.9 In humans, haemophilia is caused by a recessive allele on the X chromosome. A heterozygous, unaffected female and an unaffected male plan to have children.

What is the percentage chance that their sons will have haemophilia?

- A 0%
- B 25%
- C 50%
- D 75%

1.1.10 Scientists found that the long-term use of one type of insecticide results in the decreased control of insects.

From this finding the scientists stated that:

Insecticides resistance in insects is caused by the long-term use of one type of insecticide.

This statement is a/an ...

- A aim.
- B conclusion.
- C theory.
- D scientific theory.

(10 x 2) **(20)**

1.2 Give the correct **biological term** for each of the following descriptions. Write only the term next to the question number (1.2.1 to 1.2.8) in the ANSWER BOOK.

1.2.1 The position of a gene on a chromosome

1.2.2 The structure in an animal cell that forms spindle fibres

1.2.3 The division of the cytoplasm

1.2.4 The nitrogenous base found in messenger RNA but not in DNA

1.2.5 The process whereby a DNA molecule makes identical copies of itself

1.2.6 Having a protruding jaw

1.2.7 A group of organisms of the same species living in the same habitat at the same time

1.2.8 The permanent disappearance of a species from Earth

(8 x 1) (8)

1.3 Indicate whether each of the descriptions in COLUMN I applies to **A ONLY**, **B ONLY**, **BOTH A AND B** or **NONE** of the items in COLUMN II. Write **A only**, **B only**, **both A and B**, or **none** next to the question number (1.3.1 to 1.3.3) in the ANSWER BOOK.

	COLUMN I	COLUMN II
1.3.1	Specific type of chromosome pair number 23 in a human somatic cell	A: Gonosome B: Autosome
1.3.2	Random arrangement of chromosomes occurs	A: Metaphase I B: Metaphase II
1.3.3	Network of genetic material found in the nucleus of a non-dividing cell	A: Chromosome B: Chromatin

(3 x 2) (6)

- 1.4 The diagrams below in no particular order show the skulls of organisms (*Homo erectus*, *Homo sapiens* and a chimpanzee).

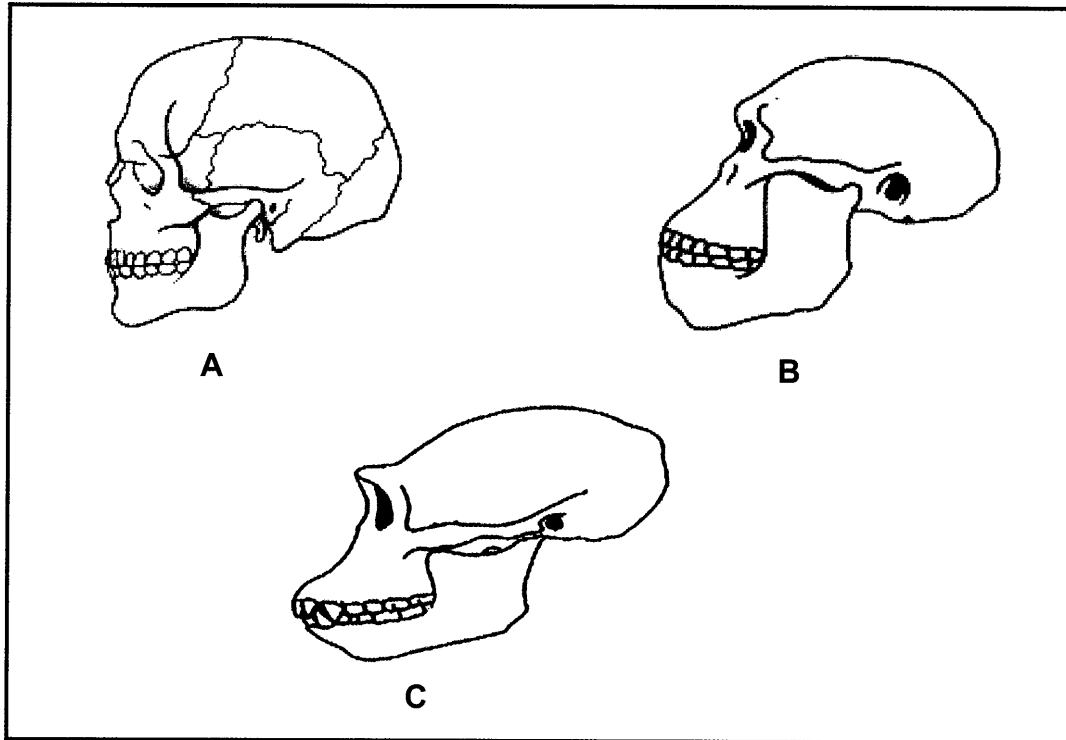

- 1.4.1 Identify the skull (**A**, **B** or **C**) that has the:
- (a) Teeth that are most adapted to raw food (1)
- (b) Foramen magnum in the most forward position (1)
- 1.4.2 State what the forward position of the foramen magnum in the skull mentioned in QUESTION 1.4.1 (b) above indicates in the ancestors of the organism. (1)
- 1.4.3 Name the organism to which the following skulls belong:
- (a) **B** (1)
- (b) **C** (1)
- 1.4.4 Give TWO characteristics of the upper limbs that the organisms represented by skull **A** and **B** share. (2)
- 1.4.5 Identify TWO visible structural differences between skulls **A** and **C**. (2)
- (9)**

- 1.5 In tomato plants, the genes for height and leaf colour are on the same homologous chromosomes. Tall plant (**T**) and dark green leaves (**G**) are dominant over short plant (**t**) and light green leaves (**g**).

A farmer carried out a cross between plants that are heterozygous for both characteristics.

The table below shows the offspring produced.

PHENOTYPE OF OFFSPRING	NUMBER OF OFFSPRING
Tall with dark green leaves	933
Tall with light green leaves	316
Short with dark green leaves	302
Short with light green leaves	101

- 1.5.1 Give the:

- (a) Allele for light green leaves (1)
- (b) Phenotype of offspring that are homozygous recessive for both characteristics (1)
- (c) Genotype of the parent plants (1)
- (d) Genotype of gametes produced by a short plant that is heterozygous for leaf colour. (2)

- 1.5.2 Write down the phenotypic ratio of the offspring shown in the table above from top to bottom. (2)
(7)

TOTAL SECTION A: 50

SECTION B**QUESTION 2**

2.1 The diagram below shows part of the process of protein synthesis.

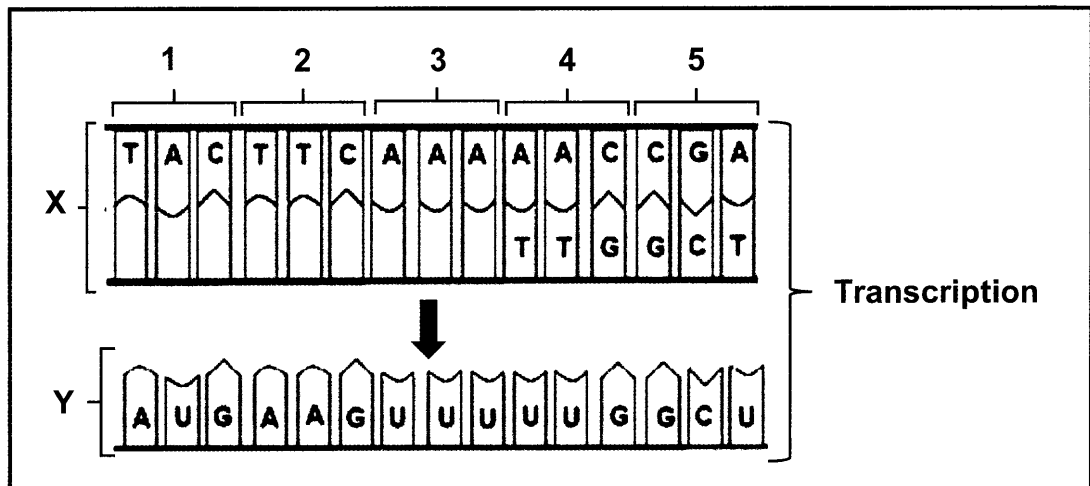

- 2.1.1 Identify molecule **X** in the diagram above. (1)
- 2.1.2 Give ONE visible reason for your answer in QUESTION 2.1.1. (1)
- 2.1.3 How many amino acids could be coded for by molecule **Y** in the diagram above? (1)
- 2.1.4 The table below shows the codons that code for different amino acids.

CODON	AMINO ACID
GCU	Alanine
GUG	Valine
AAC	Proline
UAC	Tyrosine
AUG	Methionine
AAA	Lysine

With reference to the diagram in QUESTION 2.1 and the table above:

- (a) Explain how the composition of the protein molecule will be affected if the base sequence in triplet 1 was CAC instead of TAC. (4)
- (b) Write down the DNA base triplet that codes for alanine. (1)
- (8)**

2.2 Describe the process of *transcription*. (6)

2.3 At a crime scene, three men were murdered. One of them is suspected to be Anna’s father. They could not be physically identified and DNA profiling was used to identify Anna’s father.

The diagram below shows the DNA profiles of Anna’s mother, Anna and the three men.

Mother	Anna	Man 1	Man 2	Man 3
████████	████████	████████	████████	████████
████████	████████		████████	
████████			████████	
████████		████████		████████
████████	████████	████████	████████	████████
	████████	████████	████████	
	████████	████████		████████
████████	████████	████████	████████	████████

2.3.1 Which man is most likely to have been Anna’s father? (1)

2.3.2 Explain your answer in QUESTION 2.3.1. (3)

2.3.3 Give ONE reason why the evidence from DNA profiling may be considered reliable. (1)

2.3.4 State TWO other uses of DNA profiling. (2)
(7)

2.4 The diagram below shows part of a phase in meiosis.

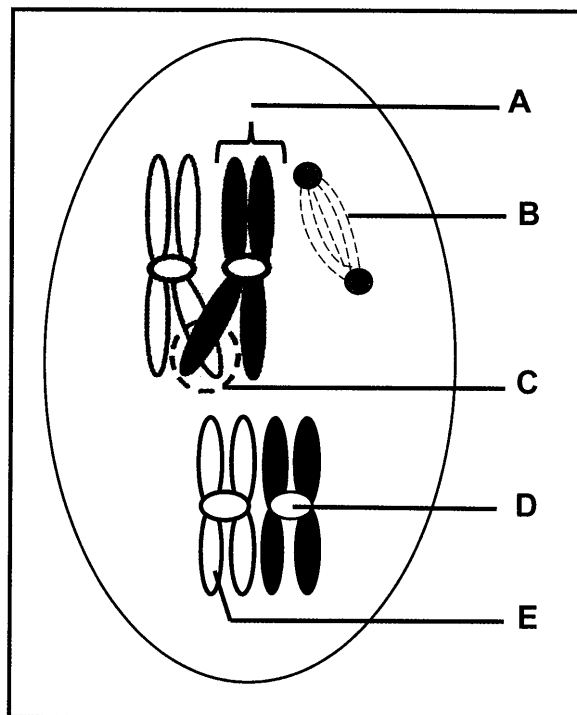

2.4.1 Identify structure:

- (a) **B** (1)
- (b) **D** (1)
- (c) **E** (1)

2.4.2 State the phase of meiosis shown. (1)

2.4.3 Name and describe the process shown at part **C**. (4)

2.4.4 Draw a diagram, with shading, to show the appearance of part **A** at the end of meiosis I. (2)

2.4.5 State **THREE** reasons why meiosis is a biologically important process. (3)
(13)

2.5 In fruit flies, red eyes (**R**) is dominant over white eyes.

The pedigree diagram below shows the inheritance of eye colour in fruit flies over a few generations.

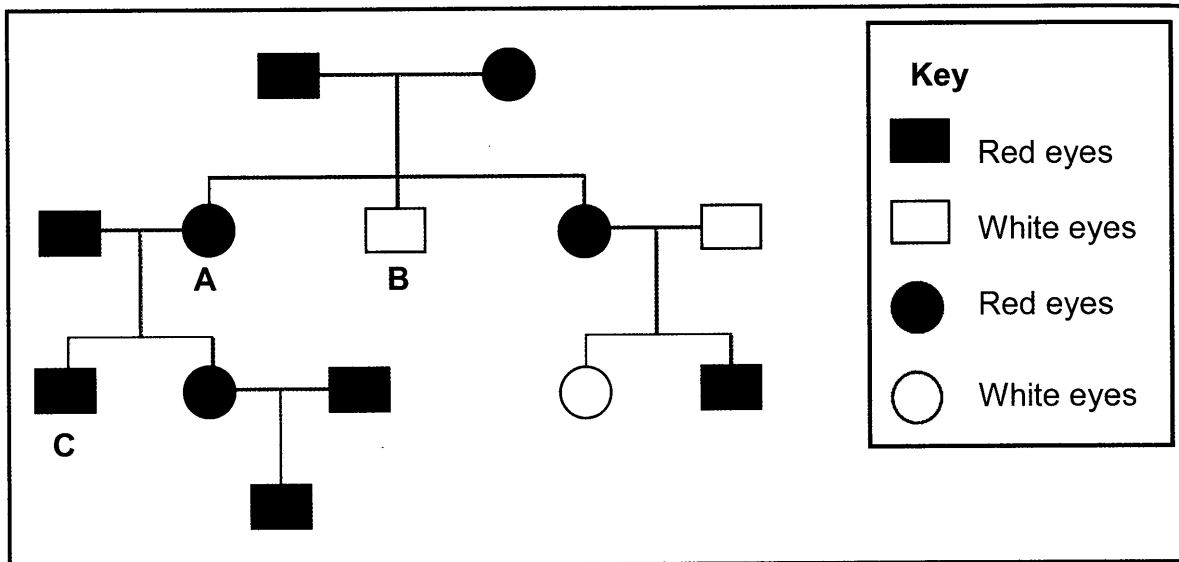

2.5.1 State the number of generations represented in this pedigree diagram. (1)

2.5.2 Give the:

(a) Phenotype of fruit fly **C** (1)

(b) Possible genotype(s) of fruit fly **A** (2)

2.5.3 Explain how offspring **B** inherited white eyes. (3)

2.5.4 Calculate the percentage of female fruit flies with red eyes. Show all working. (3)
(10)

2.6 Use a genetic cross to show how TWO parents could produce offspring of blood types O and AB amongst other blood types. (6)
(50)

QUESTION 3

3.1 Genetic engineering is an aspect of biotechnology and includes stem cell research, genetically modified organisms and cloning.

The diagram below shows part of the cloning process in sheep. (**Sheep somatic cell contains 54 chromosomes**).

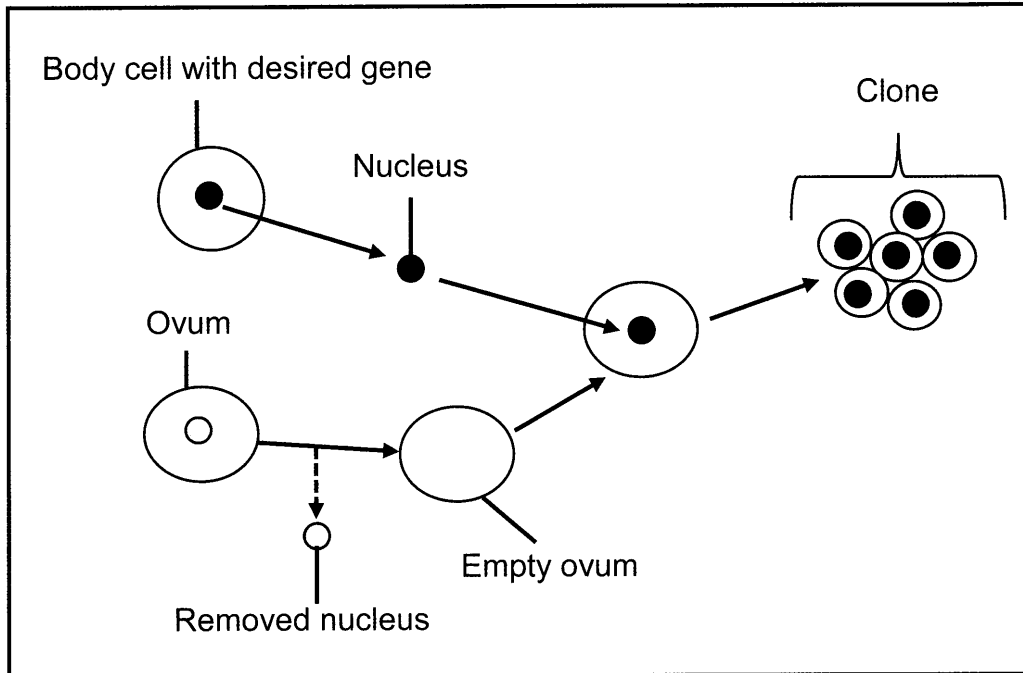

- 3.1.1 Describe what a cloning is? (2)
- 3.1.2 Explain the significance of removing the nucleus of the ovum in this process. (2)
- 3.1.3 State the number of chromosomes:
 - (a) In each cell of a clone (1)
 - (b) In the removed nucleus of the ovum (1)

(6)

3.2 Bean plants may be infected by viruses, thereby reducing the yield of bean seeds. A virus-resistant variety of bean plant was developed through genetic modification.

The two varieties, the genetically modified bean seeds (**GM seeds**) and non-genetically modified bean seeds (**non-GM seeds**) were grown.

Scientists wanted to investigate if genetically modified plants have an effect on the yield of bean seeds.

The procedure was as follows:

- Both seed types were grown in two separate fields of the same size.
- 300 bean seeds were grown in each field.
- 50 Kg of NPK fertiliser was applied in each field.

The results of the investigation are shown in the graph below.

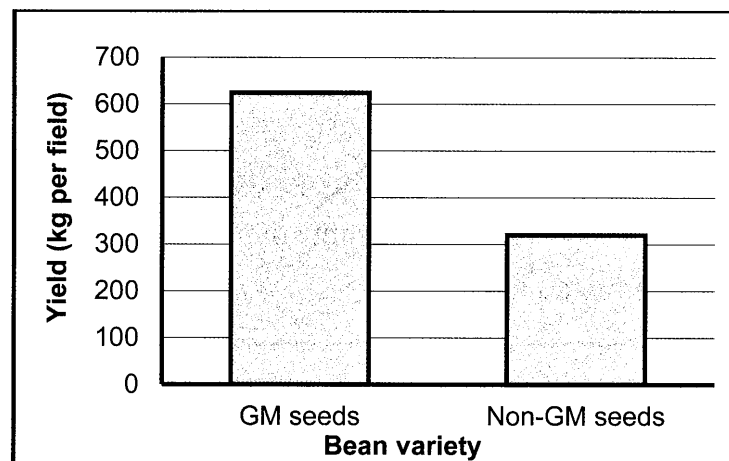

3.2.1 Identify the:

(a) Independent variable (1)

(b) Dependent variable (1)

3.2.2 State the reason why 300 seeds were grown in each field instead of 100. (1)

3.2.3 Give TWO factors that were kept constant during the investigation. (2)

3.2.4 Explain why non-genetically modified seeds were included in the investigation. (3)
(8)

- 3.3 Holly berries have red colour fruits while gooseberries have a green colour. Holly berries are poisonous to herbivores. This is a defence mechanism as herbivores avoid them. Both berries are visible to herbivores.

It was observed that where red holly berries and green gooseberries grow in the same field, there were more holly berries.

Use Darwin's theory of evolution to explain why there were more holly berries in this field. (6)

- 3.4 Tabulate TWO differences between natural selection and artificial selection. (5)

- 3.5 Read the extract below.

The big flightless birds like the emu and rhea are scattered around Australia and Brazil in the Southern hemisphere. Their present-day distribution suggests that they could have evolved from a common ancestor and evolved into the species they are today.

A new study suggests that their common ancestors once flew around the world. The Australian emu and Brazilian rhea independently evolved in such a way that made them lose the ability to fly.

- 3.5.1 Name the:

- (a) Type of evidence for evolution represented in the extract above. (1)
- (b) Characteristic in the passage that the common ancestor had, but that the rhea and emu did not have. (1)

- 3.5.2 State TWO laws that Lamarck would have used to explain how the rhea and emu lost the ability to fly. (2)

- 3.5.3 Describe the speciation of the rhea and emu. (7)
(11)

- 3.6 Scientists use fossils as evidence for human evolution. The brain volume of living hominids has been compared to the brain volume of extinct hominids.

The table below shows the period of existence and average brain volume of some hominids.

HOMINIDS	PERIOD OF EXISTENCE (mya)	AVERAGE BRAIN VOLUME (cm ³)
<i>Ardipithecus ramidus</i>	5.8 – 4.4	350
<i>Australopithecus sediba</i>	1.98	450
<i>Homo habilis</i>	2.33 – 1.4	750
<i>Homo erectus</i>	2 – 0.5	1200
<i>Homo sapiens</i>	0.2 - present	1400

3.6.1 Name TWO:

- (a) Genera from the table, whose fossils were found in Africa **only**. (2)
- (b) Lines of evidence for human evolution, other than fossil evidence. (2)

3.6.2 How long did *Ardipithecus ramidus* live on earth? (1)

3.6.3 State TWO advantages of *Homo sapiens* having a larger brain volume. (2)

3.6.4 Use evidence from the table to show that *Homo habilis* and *Homo erectus* may have existed at the same time. (1)

3.6.5 Draw a bar graph to show the average brain volume of primates in the table above. (6)

(14)
[50]

TOTAL SECTION B: 100
GRAND TOTAL: 150