

SA EXAM PAPERS This Paper was downloaded from SAEXAMPAPERS
SA's Leading Past Year

Exam Paper Portal

STUDY

You have Downloaded, yet Another Great Resource to assist you with your Studies 😊

Thank You for Supporting SA Exam Papers

Your Leading Past Year Exam Paper Resource Portal

Visit us @ www.saexampapers.co.za



**SA EXAM
PAPERS**

SA EXAM PAPERS

Proudly South African



basic education
 Department:
 Basic Education
REPUBLIC OF SOUTH AFRICA

**NATIONAL
 SENIOR CERTIFICATE**

GRADE 12

ENGINEERING GRAPHICS AND DESIGN P1
NOVEMBER 2025

MARKS: 100

TIME: 3 hours

This question paper consists of 6 pages.

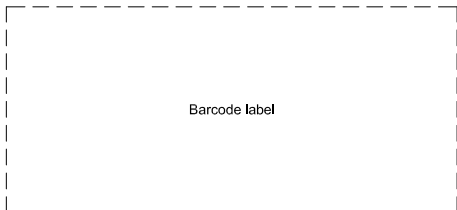

Barcode label

DO NOT FOLD THE QUESTION PAPER IN HALF.

Confidential

INSTRUCTIONS AND INFORMATION

1. This question paper consists of FOUR questions.
2. Answer ALL the questions.
3. ALL drawings are in first-angle orthographic projection, unless otherwise stated.
4. ALL drawings must be prepared using pencil and instruments, unless otherwise stated.
5. ALL answers must be drawn accurately and neatly.
6. ALL the questions must be answered on the QUESTION PAPER, as instructed.
7. ALL the pages, irrespective of whether the question was attempted or not, must be re-stapled in numerical sequence in the TOP LEFT-HAND CORNER ONLY.
8. Time management is essential in order to complete all the questions.
9. Print your examination number in the block provided on every page.
10. Any details or dimensions not given must be assumed in good proportion.

FOR OFFICIAL USE ONLY											
QUESTION	MARKS OBTAINED	½	SIGN	MODERATED	½	SIGN	RE-MARKING	½	SIGN		
1											
2											
3											
4											
TOTAL											
	2	0	0	2	0	0	2	0	0		

FINAL CONVERTED MARK	CHECKED BY
100	

COMPLETE THE FOLLOWING:
CENTRE NUMBER
CENTRE NUMBER
EXAMINATION NUMBER
EXAMINATION NUMBER



LAND SURVEYOR'S CERTIFICATE OF THE CORNER HEIGHTS AND BOUNDARY LENGTHS OF LOT 1080

CORNER HEIGHTS IN METRES		BOUNDARY LENGTHS IN MILLIMETRES	
A	60	AB	46070
B	61	BC	38840
C	59	CD	39270
D	58,5	DE	30000
E	58	EA	64780

SYMBOL LEGEND

YELLOWWOOD TREE	
PALM TREE	
PARKING FOR PEOPLE WITH DISABILITIES	
NEW 2,5 m HIGH SECURITY FENCE	

NOTE:
Contractors must verify all dimensions and levels on site before commencing work. Architects to be notified immediately of any discrepancies.

ARCHITECT'S SIGNATURE

CLIENT'S SIGNATURE

ANSWER 20

In the space below, draw, in neat freehand, the *SANS 10143* graphical symbol for:
(a) A RAMP with a gradient of 1 : 15 with the lowest point on the right
(b) The elevation/front view of a DOUBLE SINK

(a) RAMP

(b) DOUBLE SINK

REVISION	DATE	DESCRIPTION
2	02/07/2025	REDUCE LENGTH OF PARKING BAYS
1	30/06/2025	ADD SECURITY FENCE

RMB ARCHITECTS
17 LYNX ROAD
MACASSAR
7945
rmbarc@skynet.com
☎021 785 2468

PROJECT ARCHITECT:
M ENSLIN

PRINTED BY:
BIG TREE PRINTERS
DATE OF PRINT:
04/07/2025

DRAWING TITLE:
SITE PLAN

PROJECT:
PROPOSED NEW BUILDING FOR HIGH ALTITUDE DRONE DESIGNERS, 25 FIRST AVENUE, STRAND

PROJECT NUMBER: 416-25	DRAWING NUMBER: D D 1 0 1 1
DATE: 28/06/2025	DRAWN: R NEWTON
CHECKED: M ENSLIN	SCALE: 1 : 400
REFERENCE CODE: HAD-150169	DRAWING SEQUENCE: 3 of 6

QUESTION 1: ANALYTICAL (CIVIL)

Given:

The site plan of an existing building with a proposed new building, a title panel and a table of questions. The drawing is not presented to the indicated scale.

Instructions:

Complete the table below by neatly answering the questions, which refer to the accompanying drawing, title panel and civil content. [30]

QUESTIONS		ANSWERS	
1	What scale is indicated for the site plan?	1	
2	When was the second revision made to the drawing?	1	
3	What is the height of the lowest corner of LOT 1080 in metres?	1	
4	In which town is LOT 1080 situated?	1	
5	How many parking bays are shown on LOT 1080?	1	
6	How wide is the vehicle entrance and exit in millimetres?	1	
7	What does the arrow at the vehicle entrance and exit indicate?	1	
8	What is the fall of the municipal sewerage line?	1	
9	How many existing rodding eyes are indicated on LOT 1080?	1	
10	Give the full name of the feature at 1.	1	
11	Name the feature at 2.	1	
12	What security feature is added to the masonry wall on boundary CD?	1	
13	What is the abbreviation for CONCRETE?	1	
14	What colour is used to represent new steel on sectional elevations?	1	
15	On what type of drawing is brown used for drains and soil pipes?	1	
16	How many palm trees are north-west of the existing building?	2	
17	If building line P-Q is 21 m from corner S on the proposed new building, how far is corner S from FIRST AVENUE in millimetres?	2	
18	In the space below (ANSWER 18), determine the length of the new security fence in metres.	3	
19	In the space below (ANSWER 19), determine the total area of the new building in square metres.	3	
20	In the space in the title panel (ANSWER 20), draw, in neat freehand, the <i>SANS 10143</i> graphical symbol for: (a) a RAMP with a gradient of 1 : 15 with the lowest point on the right, and (b) the elevation/front view of a DOUBLE SINK.	5	
TOTAL		30	

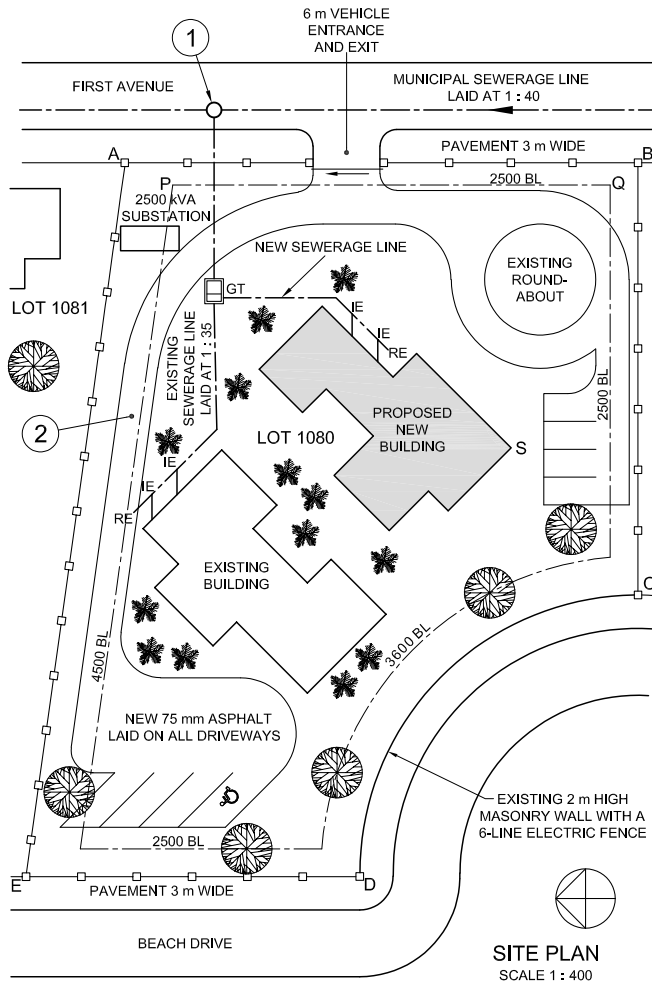

SITE PLAN
SCALE 1 : 400

ANSWER 18
Show ALL calculations.
(Do NOT round off the answer.)

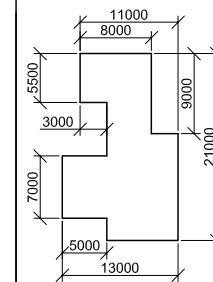

ANSWER 19
Show ALL calculations.
(Do NOT round off the answer.)

EXAMINATION NUMBER	
EXAMINATION NUMBER	2



QUESTION 2: INTERPENETRATION AND DEVELOPMENT

Given:

- The top view and incomplete front view of a right regular hexagonal prism that passes through a right regular pentagonal prism. The axes of both solids lie in a common vertical plane.
- Auxiliary views of the hexagonal prism

Instructions:

Draw, to scale 1 : 1, the following views of the TWO solids:

- 2.1 The given top view
- 2.2 The right view
- 2.3 The complete front view, clearly showing the curves of interpenetration

- Planning is essential.
- Show ALL hidden detail.
- Show ALL construction.

[39]

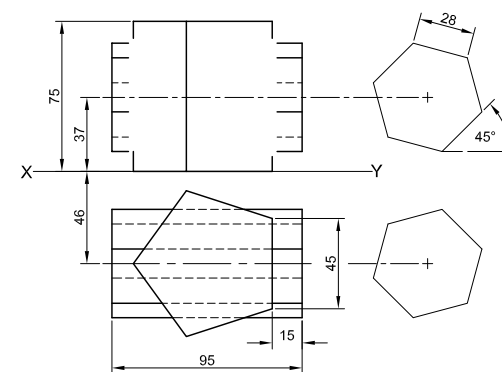

ASSESSMENT CRITERIA				
1	TOP VIEW	13		
2	FRONT VIEW	18		
3	RIGHT VIEW	8		
PENALTIES (-)				
TOTAL		39		
EXAMINATION NUMBER				
EXAMINATION NUMBER				
EXAMINATION NUMBER				3

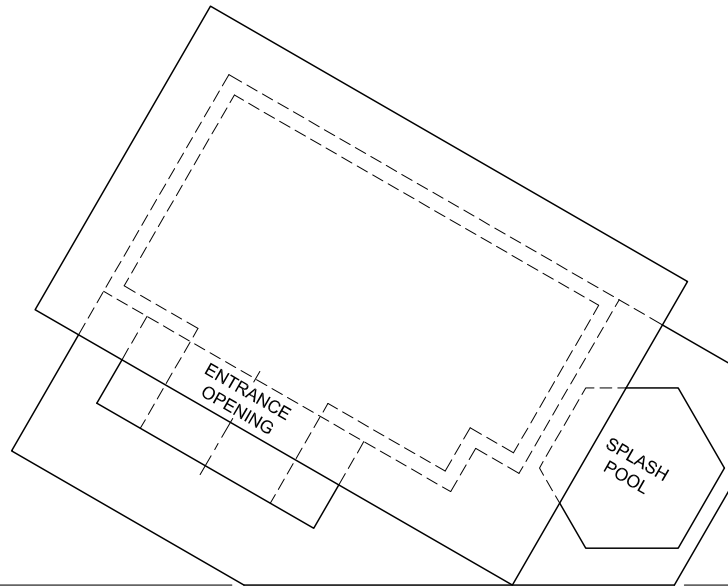

QUESTION 3: PERSPECTIVE

Given:

- Three views of a poolhouse with a splash pool and the information needed to draw a two-point perspective drawing
- PP – Picture plane
- HL – Horizon line
- GL – Ground line
- SP – Station point

Instructions:

- Complete the perspective drawing.
- Align the drawing sheet with the ground line (GL).
- Determine and label the vanishing points.
- Show ALL construction.
- Show depth at the entrance opening.
- Show interior detail as seen through the entrance opening.
- NO hidden detail is required. [41]

PP

ASSESSMENT CRITERIA				
1	CONSTRUCTION	6		
2	WALLS + PATIO	14		
3	OPENING + POOL	7		
4	ROOF	6 1/2		
5	ARC + CONSTRUCTION	7 1/2		
PENALTIES (-)				
TOTAL		41		

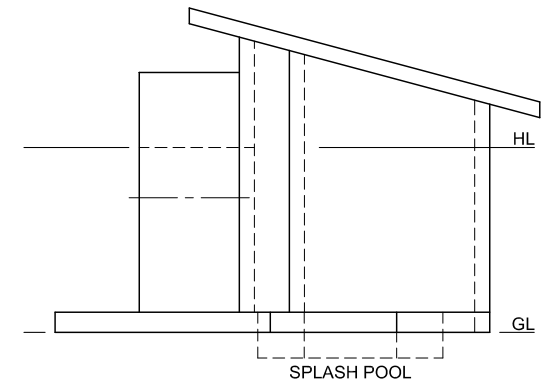
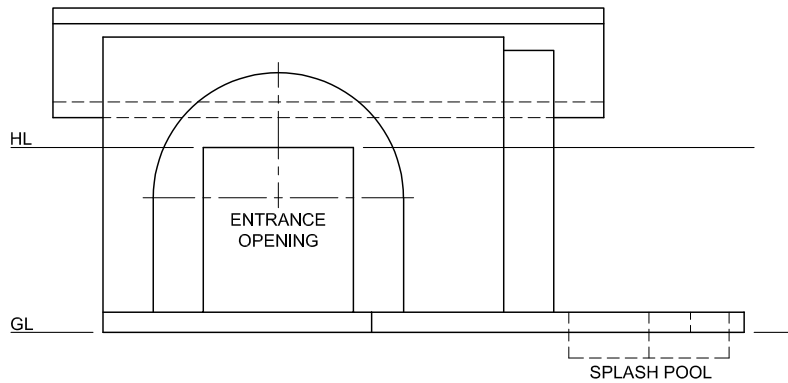

EXAMINATION NUMBER	
EXAMINATION NUMBER	4

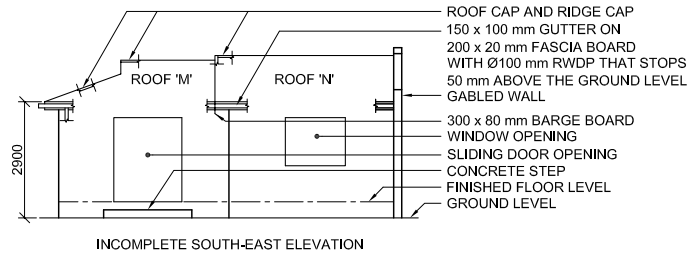

INCOMPLETE SOUTH-EAST ELEVATION

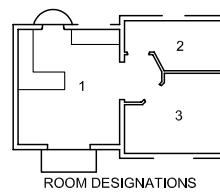

ROOM DESIGNATIONS

FLOOR FINISHES

- | | |
|-----------------|--------|
| 1. LIVING AREA: | TILE |
| 2. BATHROOM: | TILE |
| 3. BEDROOM: | CARPET |

QUESTION 4: CIVIL DRAWING

Given:

- The incomplete south-east elevation of a **new house**, showing the walls, the window and door openings, step, roof, gabled wall and labels
- The incomplete floor plan showing the walls, roof line, steps, positions of the doors, windows, fixtures and electrical layout
- An incomplete schematic diagram of a roof truss for roof 'M' and roof notes
- The incomplete gable wall detail
- The incomplete foundation, step and external wall detail
- Room designations and floor finishes
- A door and window schedule
- A table of roof components
- A table of electrical symbols
- A fixture schedule
- The incomplete floor plan and position of the ground level of the south-east elevation of the **new house**, drawn to scale 1 : 50, and the incomplete foundation and break line for the detailed section, drawn to scale 1 : 20, on page 6

Instructions:

Answer this question on page 6.

4.1 Using the given incomplete floor plan and ground level, draw, to scale 1 : 50, the following views of the **new house**:

4.1.1 THE COMPLETE FLOOR PLAN

Add the following features to the drawing:

- ALL doors and windows
- ALL fixtures as indicated by the abbreviations
- ALL electrical fittings as indicated by the numbers
- ALL hatching detail

4.1.2 THE COMPLETE SOUTH-EAST ELEVATION

Show the following features on the drawing:

- The walls, window, sliding door and step detail
- The roof detail including fascia boards, barge board, gutters and rainwater downpipe
- The finished floor level

4.2 Using the incomplete foundation and break line on page 6, draw, to scale 1 : 20, a **DETAILED SECTION** on cutting plane A-A of the area in the ellipse shown on the incomplete floor plan.

Show the following features on the drawing:

- The complete foundation, step, external wall and door detail
- The roof detail including the fascia board and gutter
- The wall, barge board and gable wall detail to the right (north-east) of cutting plane A-A
- ALL hatching detail. ONLY the substructure hatching may be drawn in neat freehand.

Label the following:

- The south-east elevation
- The floor finishes
- Ground level, finished floor level, damp-proof course and rainwater downpipes (use the correct abbreviations and show them on ALL relevant views)

NOTE:

ALL drawings must comply with the **guidelines** and **graphical symbols** as contained in **SANS 10143**. [90]

FEATURES

- D1 SLIDING DOOR
 D2 DOOR
 W1 WINDOW
 W2 WINDOW
 W3 WINDOW

FIXTURES

- S SINK
 WB WASHBASIN
 WC TOILET
 SH SHOWER
 B BATH
 BIC BUILT-IN CUPBOARD

ELECTRICAL FITTINGS

1. ONE-WAY SWITCH - SINGLE-POLE
 2. ONE-WAY SWITCH - DOUBLE-POLE
 3. FLUORESCENT LIGHT 3 x 40 W
 4. CEILING LIGHT
 5. WALL-MOUNTED LIGHT
 6. SWITCHED SOCKET OUTLET
 7. DISTRIBUTION BOARD

NOTE:

THE ARROW SHOWS THE LIGHT CONNECTION TO THE SWITCH.

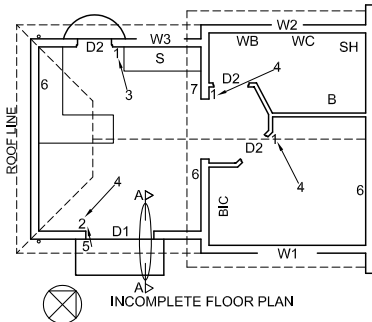

INCOMPLETE FLOOR PLAN

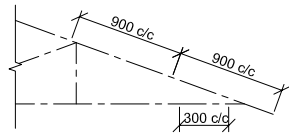

INCOMPLETE SCHEMATIC DIAGRAM OF A ROOF TRUSS FOR ROOF 'M'

ROOF NOTES:

20° ROOF PITCH

120 x 40 mm ROOF TRUSSES ON 120 x 40 mm WALL PLATES

350 mm ROOF OVERHANG TO END OF ROOF TRUSS

40 mm CORRUGATED ROOF SHEET ON 80 x 50 mm PURLINS @ 900 mm c/c

200 x 20 mm FASCIA BOARDS WITH 150 x 100 mm GUTTERS ON ALL SIDES

300 x 80 mm BARGE BOARDS SHAPED TO FIT ON THE END OF ROOF 'N', 150 mm PAST FASCIA BOARDS

10 mm CEILING BOARDS ON 40 x 40 mm BRANDING STRIPS @ 300 mm c/c

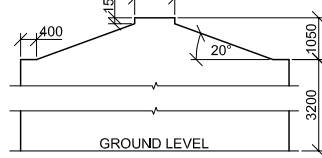

INCOMPLETE GABLE WALL DETAIL

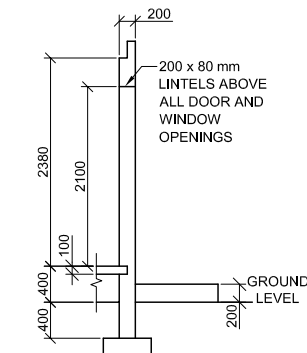

INCOMPLETE FOUNDATION, STEP AND EXTERNAL WALL DETAIL

DOOR AND WINDOW SCHEDULE

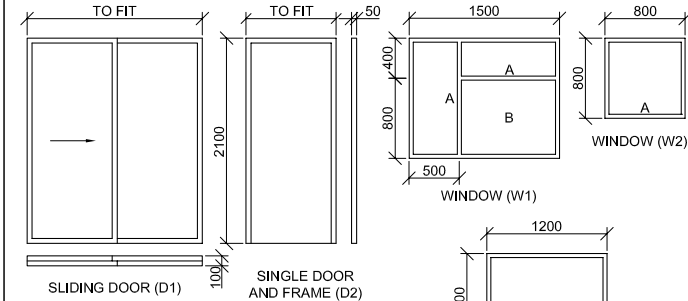

WINDOW NOTES:

- A = OPENING SIDE
- B = FIXED PANEL
- ALL FRAMES = 50 mm THICK
- 200 x 20 mm FIBRE CEMENT SILL UNDER ALL WINDOWS

ROOF COMPONENTS

	ROOF CAP AND RIDGE CAP
	300 x 80 mm BARGE BOARD
	200 x 20 mm FASCIA BOARD
	150 x 100 mm GUTTER
	80 x 50 mm PURLIN

ELECTRICAL SYMBOLS

FIXTURE SCHEDULE

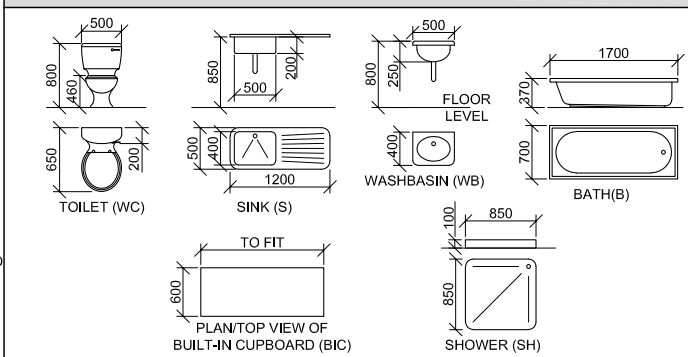

GL

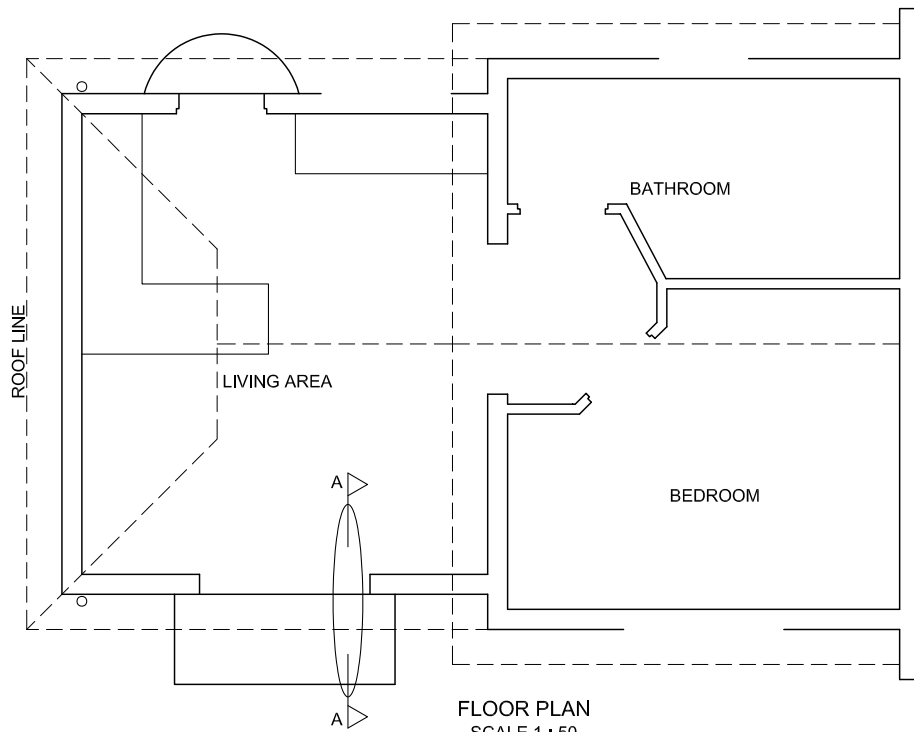

FLOOR PLAN
SCALE 1 : 50



SECTION A-A
SCALE 1 : 20

MARK ALLOCATION FOR SECTION OF ROOF		FOR OFFICIAL USE ONLY	
A		INCORRECT SCALE(S) USED	
B		NON-ALIGNMENT OF VIEWS	
C		VIEW(S) ROTATED	
D		SECTION VIEWED INCORRECTLY	
E		INCORRECT LETTERING	
F			
G			
H			
J			
K			
TOTAL		TOTAL	

ASSESSMENT CRITERIA					
FLOOR PLAN					
		POSSIBLE	OBTAINED	SIGN	MODERATED
1	DOORS + WINDOWS	11			
2	FIXTURES	10 ½			
3	ELECTRICAL	9 ½			
4	LABELS	2 ½			
5	HATCHING	3			
SUBTOTAL		36 ½			
SOUTH-EAST ELEVATION					
1	ROOF + RWDP	8 ½			
2	WALLS + STEPS	6			
3	DOOR + WINDOW	8 ½			
4	LABELS	1			
SUBTOTAL		24			
DETAILED SECTION					
1	ROOF DETAIL	12 ½			
2	SLAB + WALLS + STEP	8 ½			
3	DOOR + LINTEL	2			
4	HATCHING	5 ½			
5	LABELS	1			
SUBTOTAL		29 ½			
TOTAL		90			
PENALTIES (-)					
GRAND TOTAL					
EXAMINATION NUMBER					
EXAMINATION NUMBER					
6					