

SA EXAM PAPERS This Paper was downloaded from SAEXAMPAPERS  
**SA's Leading Past Year**

**Exam Paper Portal**



*You have Downloaded, yet Another Great Resource to assist you with your Studies 😊*

*Thank You for Supporting SA Exam Papers*

Your Leading Past Year Exam Paper Resource Portal

Visit us @ [www.saexampapers.co.za](http://www.saexampapers.co.za)



**SA EXAM  
PAPERS**

SA EXAM PAPERS

Proudly South African



# basic education

Department:  
Basic Education  
**REPUBLIC OF SOUTH AFRICA**

**NATIONAL  
SENIOR CERTIFICATE**

**GRADE 12**

**TECHNICAL MATHEMATICS P2**

**NOVEMBER 2025**

**MARKS: 150**

**TIME: 3 hours**

**This question paper consists of 17 pages, a 2-page information sheet and a 30-page SPECIAL ANSWER BOOK.**



**INSTRUCTIONS AND INFORMATION**

Read the following instructions carefully before answering the questions.

1. This question paper consists of 11 questions.
2. Answer ALL the questions in the SPECIAL ANSWER BOOK provided.
3. Clearly show ALL calculations, diagrams, graphs, etc. that you used in determining your answers.
4. Answers only will NOT necessarily be awarded full marks.
5. If necessary, round off answers to TWO decimal places, unless stated otherwise.
6. Diagrams are NOT necessarily drawn to scale.
7. You may use an approved scientific calculator (non-programmable and non-graphical), unless stated otherwise.
8. An information sheet with formulae is included at the end of the question paper.
9. Write neatly and legibly.



**QUESTION 1.**

The diagram below shows parallelogram  $ABDC$  with vertices  $A(0; -4)$ ,  $B(-2; -3)$ ,  $D$  and  $C(3; 2)$ .

$AB \parallel CD$  and  $AC \parallel BD$ .

The angle of inclination of  $AC$  with the positive  $x$ -axis is  $\theta$ .

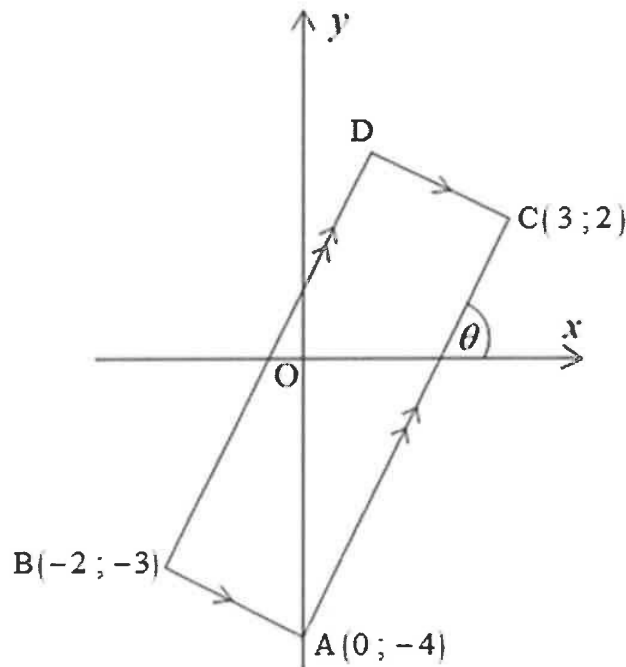

- 1.1 Write down the length of  $OA$ . (1)
- 1.2 Determine the midpoint of  $AB$ . (2)
- 1.3 Determine the gradient of  $AC$ . (2)
- 1.4 Hence, determine the size of angle  $\theta$ . (2)
- 1.5 Complete the following statement:  
If two lines are parallel, then their gradients are ... (1)
- 1.6 Hence, determine the equation of  $BD$  in the form  $y = \dots$  (3)
- 1.7 Determine the gradient of a line that passes through point  $B$  and has an inclination of  $\alpha$ , where  $\cos \alpha = -\frac{\sqrt{2}}{2}$  (3)

(3)  
[14]



**QUESTION 2**

- 2.1 In the diagram below,  $O$  is the centre of the circle which passes through points  $L(13; 0)$  and  $N(-5; k)$ .  
Tangents  $MN$  and  $ML$  touch the circle at points  $N$  and  $L$  respectively.  
 $ML \parallel y$ -axis.

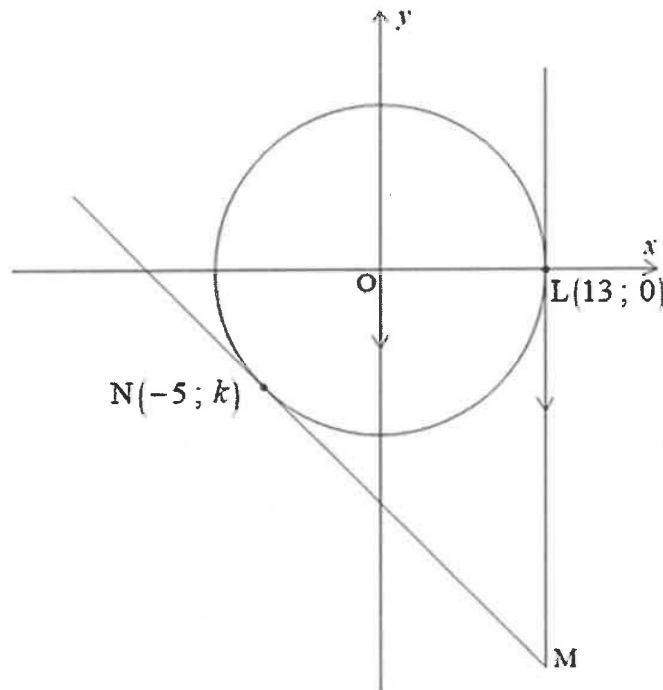

- 2.1.1 Determine the equation of the circle. (2)
- 2.1.2 Determine the numerical value of  $k$ . (2)
- 2.1.3 Hence, determine the coordinates of point  $M$ , the point of intersection of the two tangents. (5)
- 2.2 Sketch the graph defined by:  $\frac{x^2}{25} + \frac{y^2}{4} = 1$  (3)
- [12]

**QUESTION 3**

3.1 Given:  $\hat{A} = 72^\circ$  and  $\hat{B} = 30,5^\circ$

Determine the numerical value of  $\sqrt{\sin B + \sec A}$  (3)

3.2 Given:  $\sin \theta = -\frac{5}{13}$  and  $\tan \theta < 0$

Determine, **without the use of a calculator**, the numerical value of the following:

3.2.1  $\cos \theta$  (3)

3.2.2  $\cot \theta - \operatorname{cosec} \theta$  (3)

3.3 Solve for  $x$ :  $\cot x = -0,587$  for  $x \in [0^\circ; 360^\circ]$  (4)  
[13]

**QUESTION 4**

4.1 Given the expression:

$$\frac{\sin(180^\circ + x) \cdot \sin(360^\circ - x) + \cos(2\pi - x) \cdot \cos x}{\sin x} + \frac{1}{\tan(180^\circ + x)}$$

4.1.1 Complete the reduction:  $\tan(180^\circ + x) = \dots$  (1)

4.1.2 Complete the quotient identity in terms of sine and cosine:  
 $\cot x = \frac{\dots}{\dots}$  (1)

4.1.3 Write down any TWO values of  $x$  for which the expression is undefined if  $x \in [0^\circ; 360^\circ]$  (2)

4.1.4 Hence, simplify the given expression fully. (5)

4.2 Given:  $\frac{\sin \theta - \cos \theta \cdot \sin \theta}{\cos \theta - (1 - \sin^2 \theta)} = \tan \theta$

4.2.1 Factorise the expression:  $\sin \theta - \cos \theta \cdot \sin \theta$  (1)

4.2.2 Hence, show that  $\frac{\sin \theta - \cos \theta \cdot \sin \theta}{\cos \theta - (1 - \sin^2 \theta)} = \tan \theta$  (3)  
[13]



**QUESTION 5**

The graph below represents the functions defined by  $g(x) = \cos(x - p)$  and  $h(x) = \sin mx$  for  $0^\circ \leq x \leq 180^\circ$

$R(165^\circ; -0,5)$  is a point of intersection of  $g$  and  $h$ .

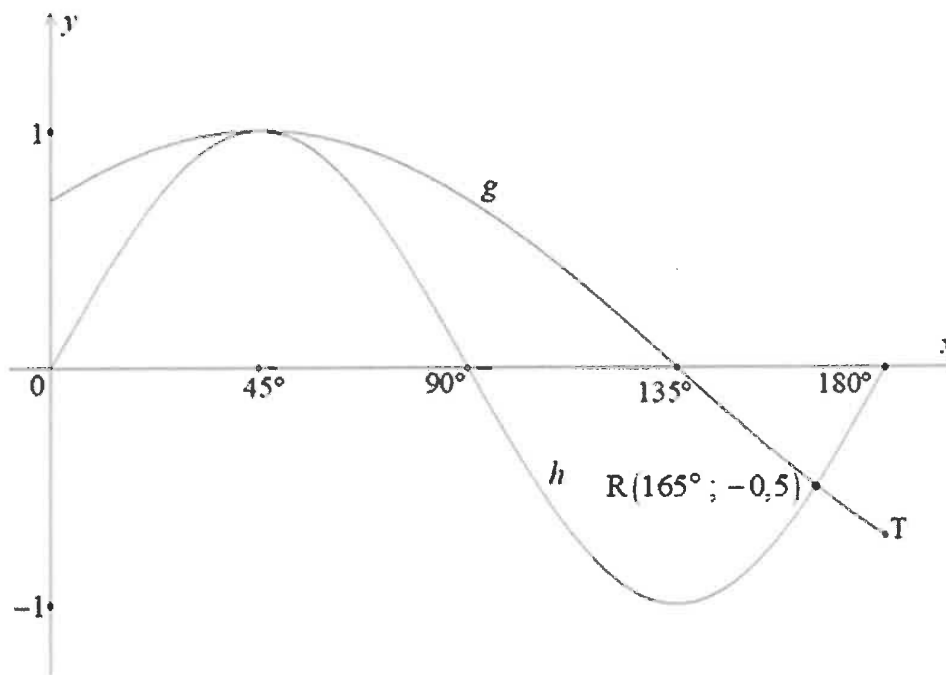

- 5.1 Determine the values of  $p$  and  $m$ . (2)
- 5.2 Write down the period of  $h$ . (1)
- 5.3 Write down the maximum value of  $g$ . (1)
- 5.4 Use the graph above to write down the values of  $x$  for which:
- 5.4.1  $g(x) < h(x)$  (2)
- 5.4.2  $g(x) \cdot h(x) \geq 0$  (4)
- 5.5 If the graph of  $h$  is shifted 1 unit downwards, write down the new equation of  $h$ . (1)

**[11]**

**QUESTION 6**

In the diagram below, SRPM is a trapezium with  $PM = 20\text{ m}$ ,  $SR = 30\text{ m}$ ,

$\hat{P} = 120^\circ$  and  $\hat{RMP} = 30^\circ$ .

$SR \parallel MP$

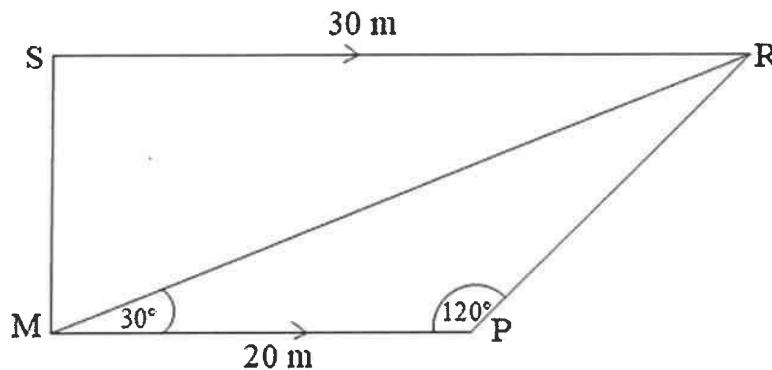

- 6.1 Write down the size of  $\hat{MRP}$ . (1)
- 6.2 What type of triangle is  $\triangle MRP$ ? (1)
- 6.3 Determine the length of MR. (Leave your answer in simplified surd form.) (3)
- 6.4 Write down the size of  $\hat{MRS}$ . Give a reason for your answer. (2)
- 6.5 Hence, determine whether  $\triangle MRS$  is a right-angled triangle. (5)
- [12]**



Give reasons for your statements in QUESTIONS 7, 8 and 9.

**QUESTION 7**

- 7.1 Below is drawn a circle with centre O.  
 A, B, C, D and E are on the circle.  
 CA is a diameter.  
 AB, CD and DE are drawn.  
 $BC \parallel AE$   
 $\hat{A}_1 = 20^\circ$

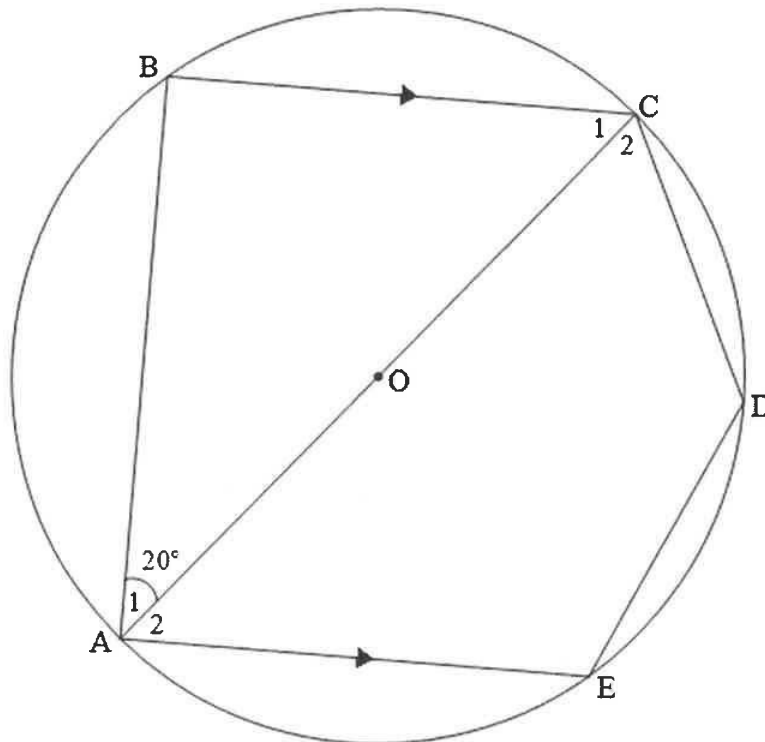

- 7.1.1 Give a reason why  $\hat{B} = 90^\circ$ . (1)
- 7.1.2 Determine, with reasons, the size of  $\hat{D}$ . (3)

- 7.2 In the diagram below, A, B, C and D are four points on the circumference of the circle.  
Chords BD and AC intersect at point E.  
Chords DC and AB are drawn.

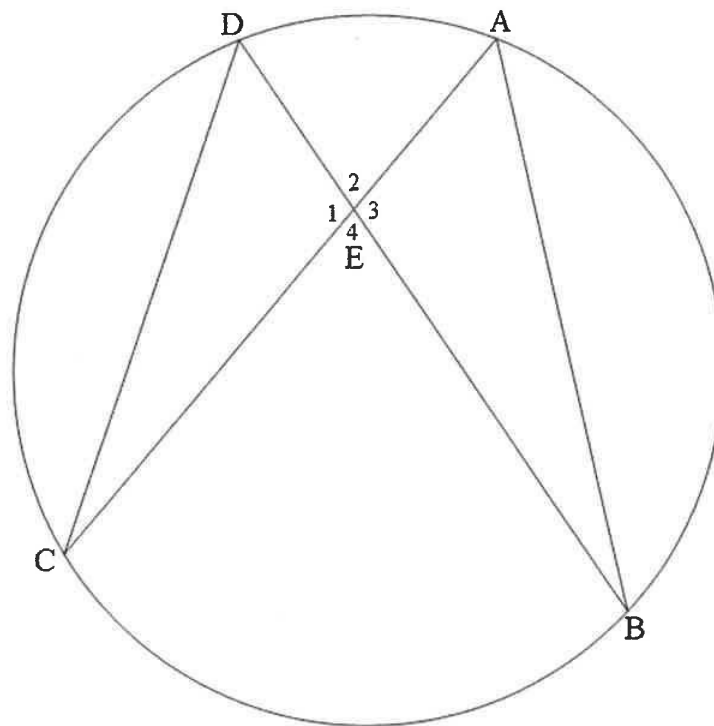

- 7.2.1 Complete the statement of the following theorem:

Angles subtended by a chord of a circle, on the same side of the chord,  
are ... (1)

- 7.2.2 Write reasons for the statements given below:

| STATEMENT                                   | REASON |
|---|--------|
| (a) $\hat{CDB} = \hat{CAB}$                 | ...    |
| (b) $\hat{E}_1 = \hat{E}_3$                 | ...    |
| (c) $\triangle DEC \parallel \triangle AEB$ | ...    |

(1)

(1)

(1)

**[8]**

**QUESTION 8**

8.1 In the diagram below, G, B, A and D are points on a circle with centre C. GD, GA and GB are drawn.

$$AB = AD$$

$$\hat{ACB} = 40^\circ$$

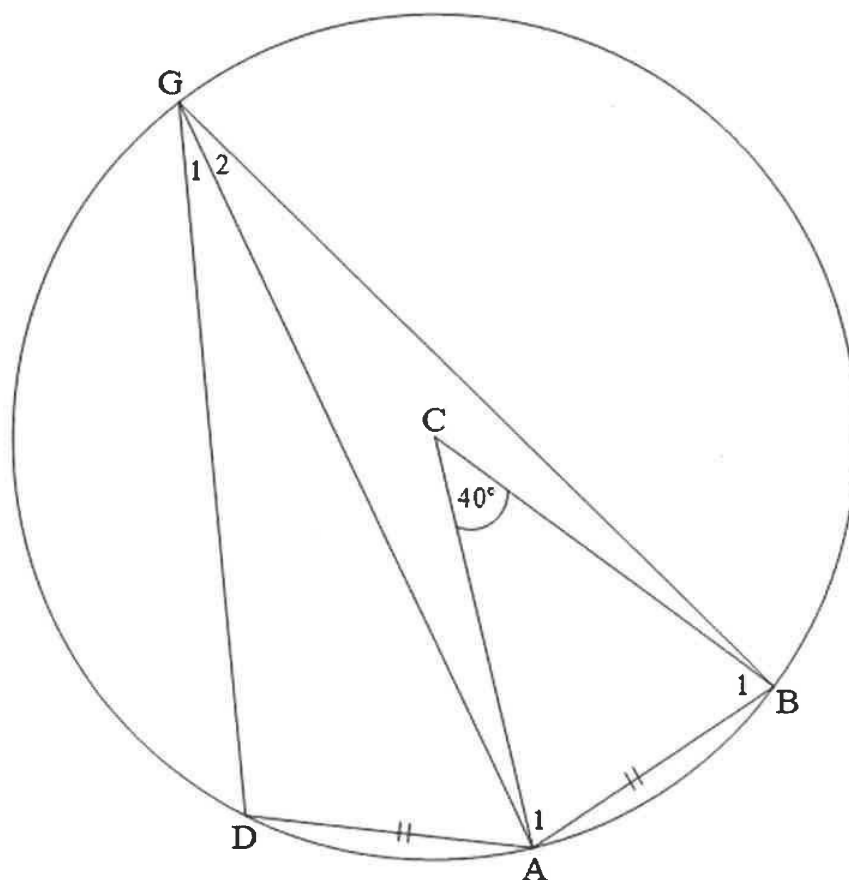

8.1.1 Write down TWO angles that will be equal if  $AB = AD$ . (1)

8.1.2 Determine, with a reason, the size of  $\hat{G}_2$ . (2)

8.1.3 Give a reason why  $\hat{A}_1 = \hat{B}_1$ . (1)

8.1.4 Determine, with a reason, the size of  $\hat{A}_1$ . (2)

8.1.5 Determine, with a reason, the size of  $\hat{DAC}$ . (3)



8.2 Complete the statement of the following theorem by filling in the missing information:

The (8.2.1) ... angle of a cyclic quadrilateral is equal to the (8.2.2) ... opposite angle. (2)

8.3 In the diagram below, A, B, C and D lie on the circumference of the circle.

E is the point of intersection of chords BD and AC.

Chord BC is produced to F.

$$\hat{B}AD = 79^\circ \text{ and } \hat{B}_2 = 30^\circ$$

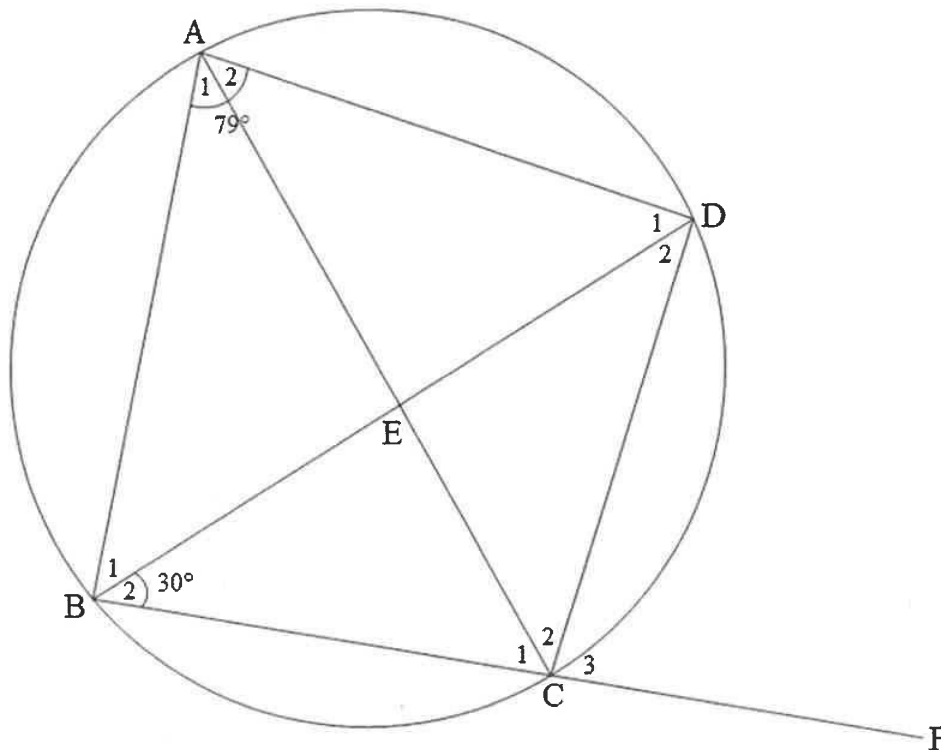

8.3.1 Determine, with reasons, the size of the following angles:

(a)  $\hat{C}_3$  (2)

(b)  $\hat{D}_2$  (2)

(c)  $\hat{D}_1$  if it is given that  $AB \parallel CD$  (3)

8.3.2 Show that  $CE = DE$  (4)  
[22]

**QUESTION 9**

9.1  $\triangle ABC$  with  $BC \parallel DE$  is drawn below.

$$AE = 4 \text{ units}$$

$$BE = 8 \text{ units}$$

$$CD = 12 \text{ units}$$

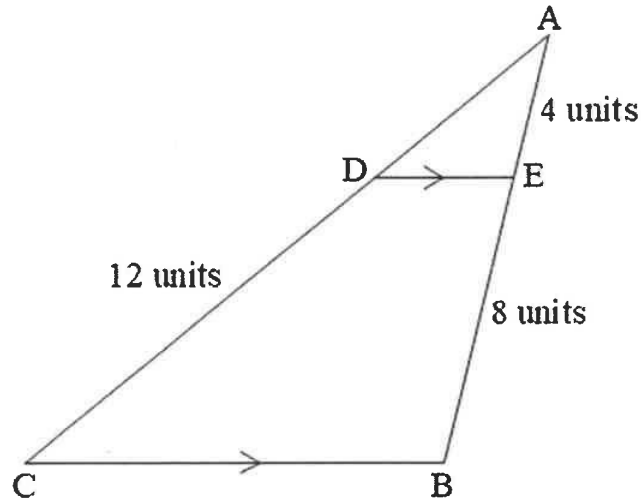

9.1.1 Complete the following statement and reason:

| STATEMENT                       | REASON                     |
|---------------------------------|----------------------------|
| $\frac{AD}{CD} = \frac{AE}{BE}$ | Prop. theorem ; ...    ... |

(2)

9.1.2 Hence, or otherwise, determine the length of AD.

(2)



- 9.2 Given:  $\triangle DEF$  with  $EF = 4$  units,  $DE = 3$  units and  $DF = 5$  units,  
 $\triangle GHI$  with  $HI = 10$  units,  $GH = 7,5$  units and  $GI = 12,5$  units

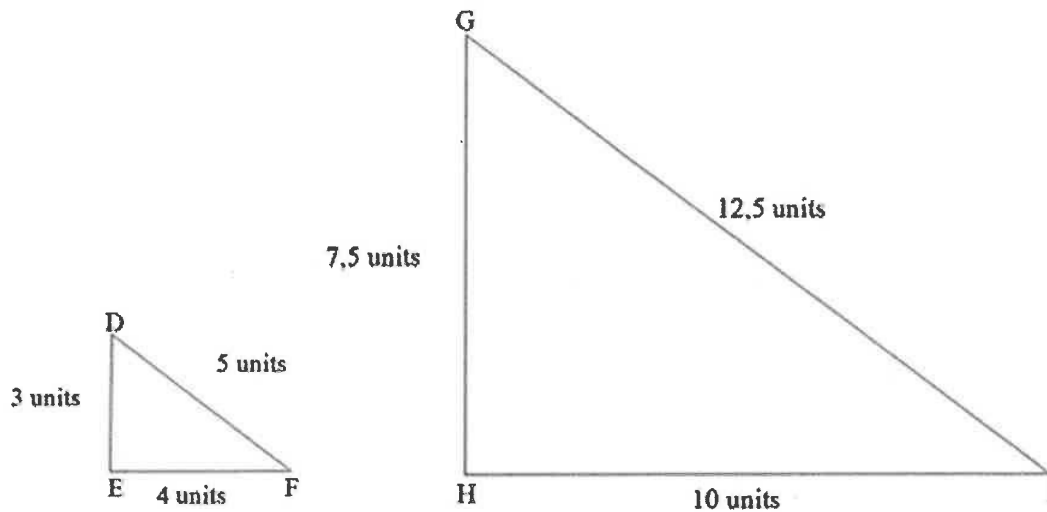

Prove that  $\triangle DEF \parallel \triangle GHI$ .

(4)  
[8]

**QUESTION 10**

10.1 The diagram below models the rotating blade of a lawnmower, as shown in the picture alongside it.

- The circular body of the lawnmower has a radius  $BD = 310$  mm.
- The length of the rotating blade from the centre of the circular body,  $D$ , to its edge,  $F$ , is  $300$  mm.
- The blade rotates at an angular velocity of  $377$  radians per second.

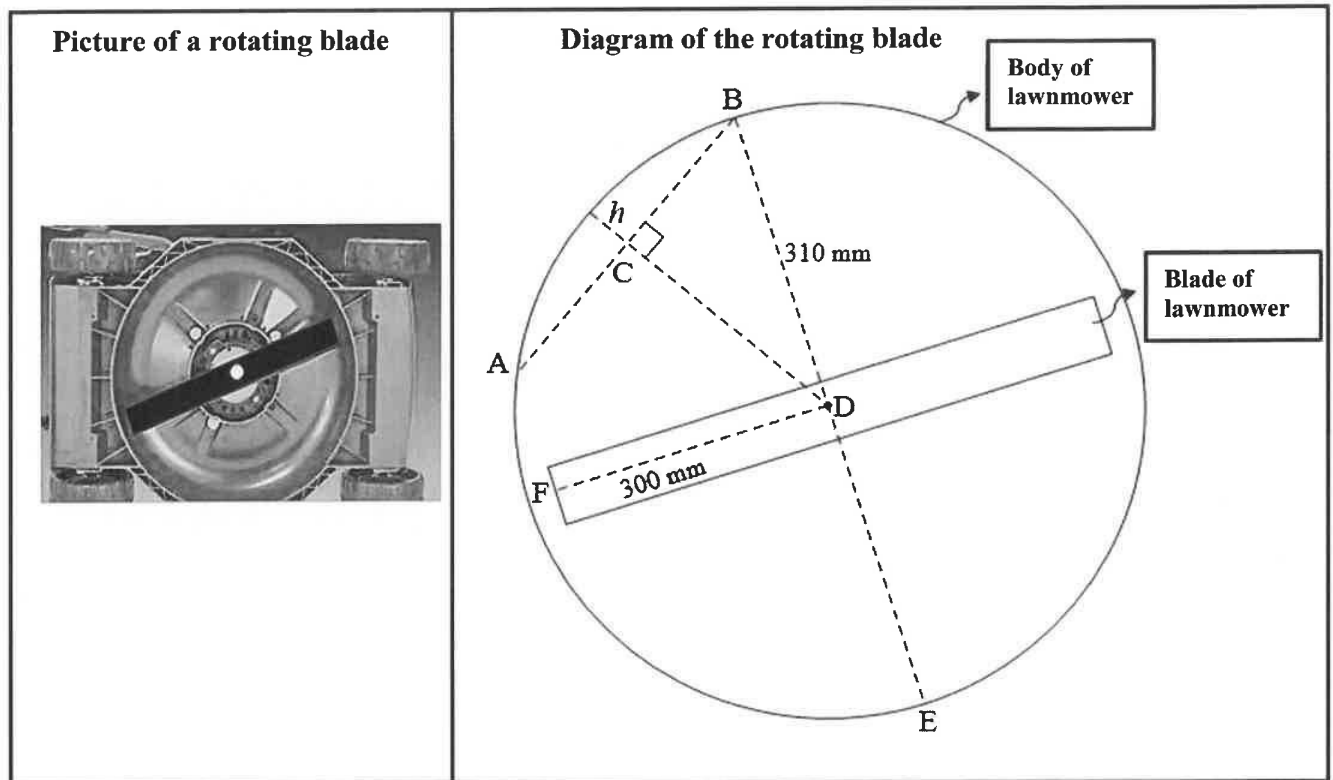

Determine:

- 10.1.1 The rotational frequency of the blade, in revolutions per second (3)
- 10.1.2 The circumferential velocity of the rotating blade in millimetres per second (3)
- 10.1.3 The height ( $h$ ) of the minor segment of chord  $AB$  if  $CD \perp AB$  and  $AB = 130$  mm (5)

10.2 The picture and the diagram below show a sector in a circular garden with a radius of 4,5 m.

The size of obtuse angle  $\hat{B}OC = 115^\circ$

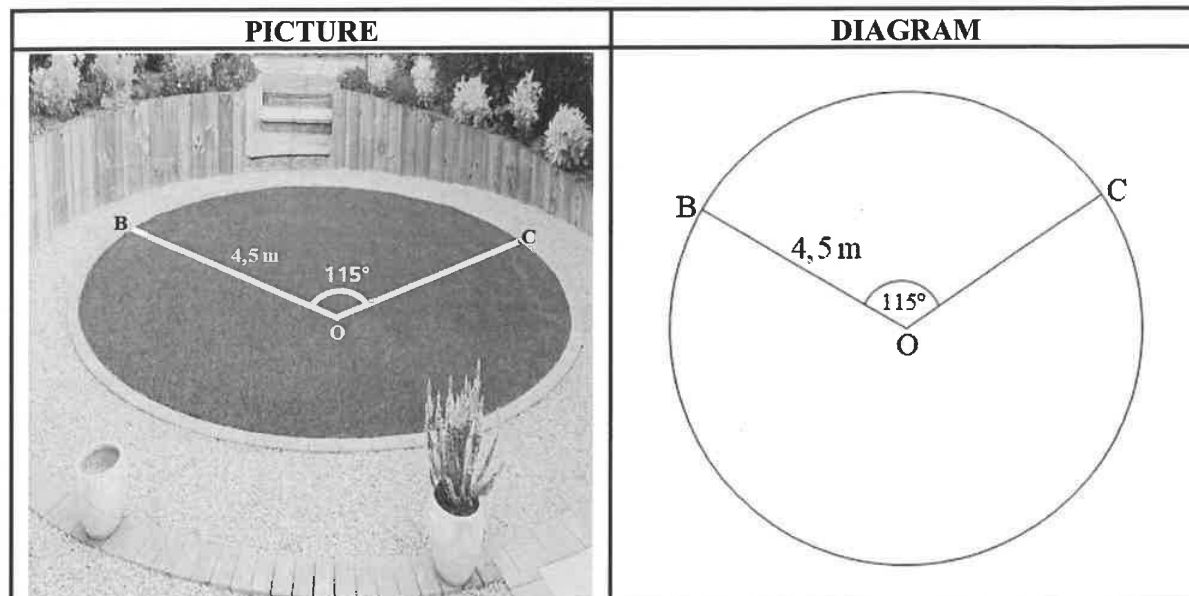

10.2.1 Convert  $115^\circ$  to radians. (1)

10.2.2 Determine the area of minor sector BOC. (3)

10.2.3 The gardener has to plant flower seedlings in the shaded area BDEC, as shown in the diagram below.  
The ratio of  $BD : DO = 2 : 3$ .

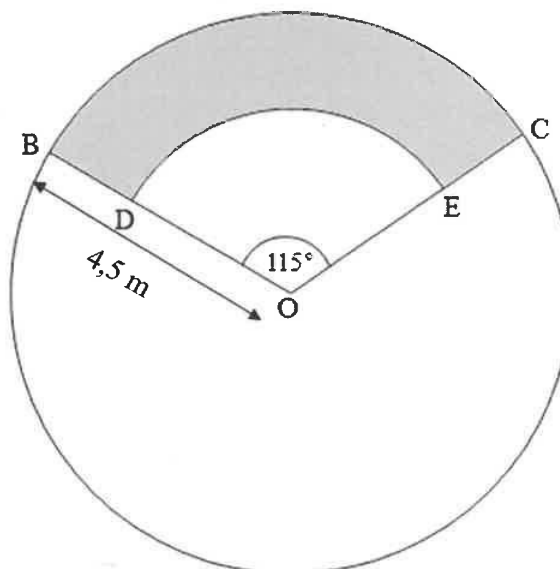

Determine the number of seedlings needed to be planted in the shaded area if 4 seedlings are planted per square metre.

(5)  
[20]

**QUESTION 11**

11.1 The diagram below shows an irregular shape with one straight side of length 120 cm, divided into 4 equal parts.

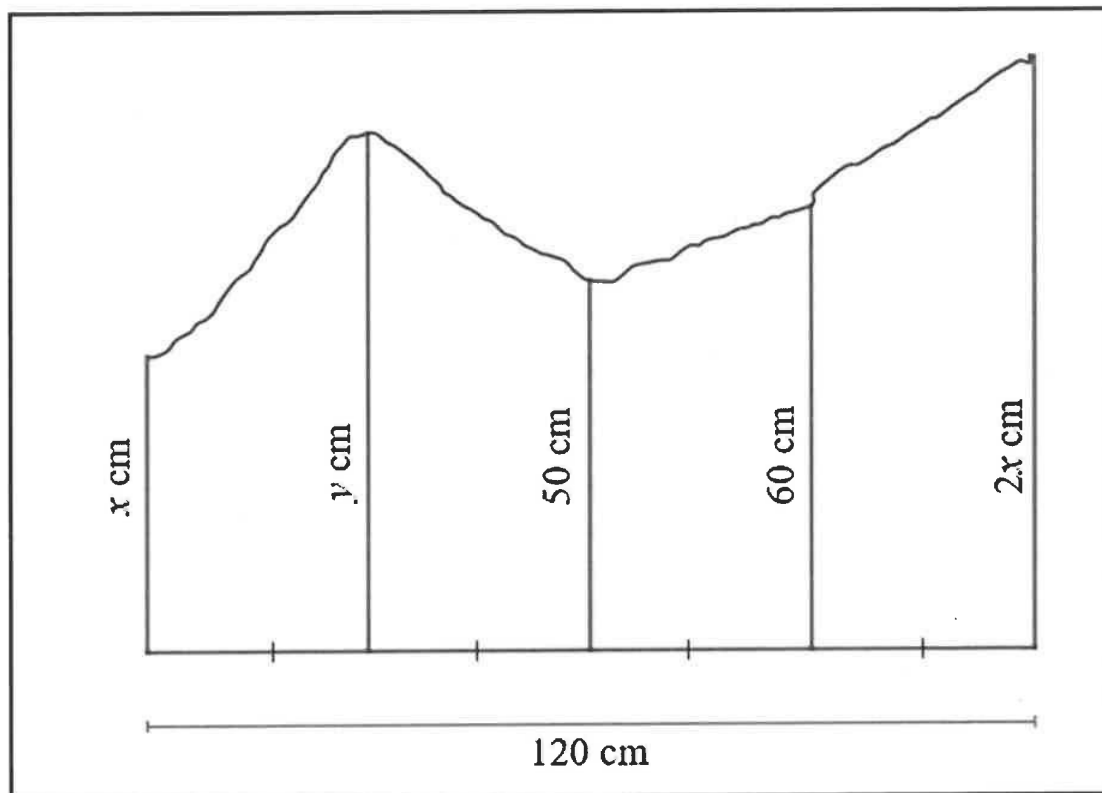

- The ordinates dividing these parts are  $x$  cm,  $y$  cm, 50 cm, 60 cm and  $2x$  cm respectively.



- 11.1.1 Write down the length of each equal part. (1)
- 11.1.2 Write down the value of  $y$ , the 2<sup>nd</sup> ordinate, if it is 20 cm longer than the middle ordinate. (1)
- 11.1.3 Use the mid-ordinate rule to determine the value of  $x$  if the area of the irregular shape is 7 200 cm<sup>2</sup>. (4)

11.2 A company melts cylindrical steel rods to manufacture solid steel ball bearings, as shown in the picture below. The diagram below each picture gives the dimensions of each shape.

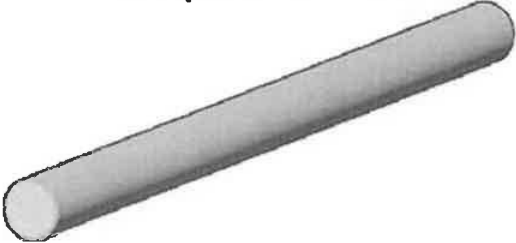
- The cylindrical steel rod has a diameter of 20 cm and a height of 0,5 m.
- The steel ball bearing has a diameter of 40 mm.

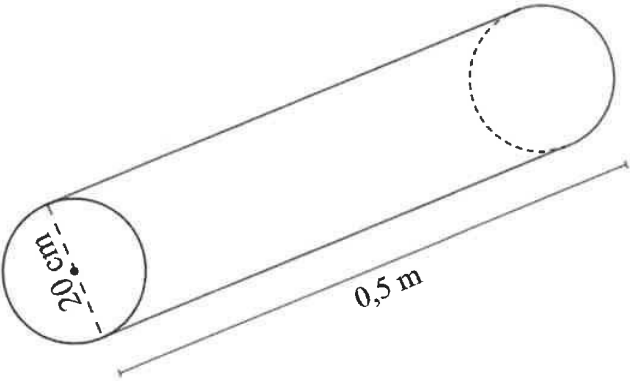
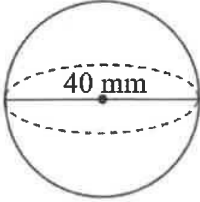
|  |   |
|--|---|
| <b>Solid cylindrical steel rod</b><br>                | <b>Solid steel ball bearing</b><br>          |
| <b>Dimensions of solid cylindrical steel rod</b><br> | <b>Dimensions of steel ball bearing</b><br> |

The following formulae may be used:

**Total surface area of cylinder**  $= 2\pi r^2 + 2\pi rh$       **Volume of cylinder**  $= \pi r^2 h$

**Total surface area of sphere**  $= 4\pi r^2$       **Volume of sphere**  $= \frac{4}{3}\pi r^3$

- 11.2.1 Convert 0,5 m to centimetres. (1)
- 11.2.2 Calculate the length of the radius of the steel ball bearing in centimetres. (2)
- 11.2.3 Determine the total surface area of the cylindrical steel rod in  $\text{cm}^2$ . (2)
- 11.2.4 Determine whether more than 400 steel ball bearings can be manufactured from one melted cylindrical rod if there is 18% loss of steel during the melting process. (6)

[17]

**TOTAL: 150**

**INFORMATION SHEET: TECHNICAL MATHEMATICS**

$$x = \frac{-b \pm \sqrt{b^2 - 4ac}}{2a}$$

$$x = -\frac{b}{2a}$$

$$y = \frac{4ac - b^2}{4a}$$

$$a^x = b \Leftrightarrow x = \log_a b, \quad a > 0, a \neq 1 \text{ and } b > 0$$

$$A = P(1 + ni)$$

$$A = P(1 - ni)$$

$$A = P(1 + i)^n$$

$$A = P(1 - i)^n$$

$$i_{eff} = \left(1 + \frac{i}{m}\right)^m - 1$$

$$f'(x) = \lim_{h \rightarrow 0} \frac{f(x+h) - f(x)}{h}$$

$$\int kx^n dx = k \cdot \frac{x^{n+1}}{n+1} + C, \quad n \neq -1$$

$$\int \frac{k}{x} dx = k \cdot \ln x + C, \quad x > 0$$

$$\int k a^{nx} dx = k \cdot \frac{a^{nx}}{n \ln a} + C, \quad a > 0$$

$$d = \sqrt{(x_2 - x_1)^2 + (y_2 - y_1)^2}$$

$$M\left(\frac{x_2 + x_1}{2}; \frac{y_2 + y_1}{2}\right)$$

$$y = mx + c$$

$$y - y_1 = m(x - x_1)$$

$$m = \frac{y_2 - y_1}{x_2 - x_1}$$

$$\tan \theta = m$$

$$\frac{x^2}{a^2} + \frac{y^2}{b^2} = 1$$

$$\text{In } \triangle ABC: \frac{a}{\sin A} = \frac{b}{\sin B} = \frac{c}{\sin C}$$

$$a^2 = b^2 + c^2 - 2bc \cdot \cos A$$

$$\text{Area of } \triangle ABC = \frac{1}{2} ab \cdot \sin C$$

$$\sin^2 \theta + \cos^2 \theta = 1$$

$$1 + \tan^2 \theta = \sec^2 \theta$$

$$1 + \cot^2 \theta = \operatorname{cosec}^2 \theta$$



$$\pi \text{ rad} = 180^\circ$$

$$\text{Angular velocity} = \omega = 2 \pi n \quad \text{where } n = \text{rotation frequency}$$

$$\text{Circumferential velocity} = v = \pi D n \quad \text{where } D = \text{diameter and } n = \text{rotation frequency}$$

$$\text{Circumferential velocity} = v = \omega r \quad \text{where } \omega = \text{angular velocity and } r = \text{radius}$$

$$\text{Arc length} = s = r\theta \quad \text{where } r = \text{radius and } \theta = \text{central angle in radians}$$

$$\text{Area of a sector} = \frac{r s}{2} \quad \text{where } r = \text{radius, } s = \text{arc length}$$

$$\text{Area of a sector} = \frac{r^2 \theta}{2} \quad \text{where } r = \text{radius and } \theta = \text{central angle in radians}$$

$$4h^2 - 4dh + x^2 = 0 \quad \text{where } h = \text{height of segment, } d = \text{diameter of circle} \\ \text{and } x = \text{length of chord}$$

$$A_T = a(m_1 + m_2 + m_3 + \dots + m_n) \quad \text{where } a = \text{width of equal parts, } m_1 = \frac{o_1 + o_2}{2} \\ o_n = n^{\text{th}} \text{ ordinate and } n = \text{number of ordinates}$$

**OR**

$$A_T = a \left( \frac{o_1 + o_n}{2} + o_2 + o_3 + \dots + o_{n-1} \right) \quad \text{where } a = \text{width of equal parts, } o_n = n^{\text{th}} \text{ ordinate} \\ \text{and } n = \text{number of ordinates}$$

