

SA EXAM PAPERS This Paper was downloaded from SAEXAMPAPERS
SA's Leading Past Year

Exam Paper Portal



You have Downloaded, yet Another Great Resource to assist you with your Studies 😊

Thank You for Supporting SA Exam Papers

Your Leading Past Year Exam Paper Resource Portal

Visit us @ www.saexampapers.co.za



**SA EXAM
PAPERS**

SA EXAM PAPERS

Proudly South African



basic education

Department:
Basic Education
REPUBLIC OF SOUTH AFRICA

**NATIONALE
SENIOR SERTIFIKAAT**

GRAAD 12

TEGNIESE WETENSAPPE V2

NOVEMBER 2025

PUNTE: 75

TYD: 1½ uur

Hierdie vraestel bestaan uit 13 bladsye en 4 gegewensblaaie.



INSTRUKSIES EN INLIGTING

1. Skryf jou sentrumnommer en eksamennummer in die toepaslike ruimtes op die ANTWOORDEBOEK neer.
2. Hierdie vraestel bestaan uit SEWE vrae. Beantwoord AL die vrae in die ANTWOORDEBOEK.
3. Begin ELKE vraag op 'n NUWE bladsy in die ANTWOORDEBOEK.
4. Nommer die antwoorde korrek volgens die nommeringstelsel wat in hierdie vraestel gebruik is.
5. Laat EEN reël tussen twee subvrae oop, bv. tussen VRAAG 2.1 en VRAAG 2.2.
6. Jy mag 'n nieprogrammeerbare sakrekenaar gebruik.
7. Jy word aangeraai om die aangehegte GEGEWENSBLAAIE te gebruik.
8. Rond jou FINALE numeriese antwoorde tot 'n minimum van TWEE desimale plekke af.
9. Gee kort (bondige) motiverings, besprekings, ens. waar nodig.
10. Skryf netjies en leesbaar.



VRAAG 1: MEERVOUDIGEKEUSE-VRAE...

Verskeie opsies word as moontlike antwoorde op die volgende vrae gegee. Kies die antwoord en skryf slegs die letter (A–D) langs die vraagnommers (1.1 tot 1.5) in die ANTWOORDEBOEK neer, bv. 1.6 D.

- 1.1 Watter EEN van die volgende reaksietipes kan vir die voorbereiding van propaan uit propeen gebruik word?
- A Oksidasie
- B Hidrolise
- C Halogenering
- D Hidrogenering (2)
- 1.2 Watter EEN van die volgende lyste van verbindings is in volgorde van afnemende kookpunte gerangskik?
- A Pentanoësuur; butan-1-ol; propaan
- B Propaan; pentanoësuur; butan-1-ol
- C Butan-1-ol; propaan; pentanoësuur
- D Propaan; butan-1-ol; pentanoësuur (2)
- 1.3 ... is 'n versadigde koolwaterstof.
- A $\text{CH}_3(\text{CH}_2)_2\text{CHCH}_2$
- B $\text{CH}_3\text{CHCHCH}_2\text{CH}_3$
- C $\text{CH}_3\text{C}(\text{CH}_3)_2\text{CHCH}_2$
- D $\text{CH}_3\text{CH}_2\text{CH}(\text{CH}_3)\text{CH}_3$ (2)
- 1.4 Die elemente in die periodieke tabel wat vir dotering gebruik kan word, is ...

	TRIVALENTE MATERIAAL	PENTAVALENTE MATERIAAL
A	Al	Be
B	B	As
C	C	N
D	B	S

(2)



1.5 Beskou die volgende stellings:

- (i) Die anode van 'n galvaniese sel is positief.
- (ii) Elektroplatering van metale vind in 'n elektrolitiese sel plaas.
- (iii) Oksidasie vind by die negatiewe elektrode van 'n galvaniese sel plaas.

Watter stelling(s) is KORREK?

- A Slegs (i)
- B Slegs (iii)
- C (ii) en (iii)
- D (i), (ii) en (iii)

(2)
[10]



VRAAG 2 (Begin op 'n nuwe bladsy.)

Die letters **A** tot **F** in die tabel hieronder verteenwoordig ses organiese verbindings.

<p>A</p> <pre> H H H H H H - C - C - C - C - C - H H H H H H </pre>	<p>B</p> <p>Etielbutanoaat</p>
<p>C</p> <pre> H H \ / C / \ H C = O C - H H </pre>	<p>D</p> <pre> H H H \ / C - C - C - H // H - C H H \ H </pre>
<p>E</p> <pre> H H H - C - C ≡ C H H </pre>	<p>F</p> <pre> H H H H - C - C - C - H H Br C - H H </pre>

2.1 Skryf die letter neer wat die volgende verteenwoordig:

- 2.1.1 'n Versadigde koolwaterstof (1)
- 2.1.2 'n Verbinding wat 'n isomeer van but-2-een is (1)
- 2.1.3 'n Alkyn (1)

2.2 Skryf neer die:

2.2.1 NAAM van die funksionele groep van verbinding **C** (1)

2.2.2 IUPAC-naam van verbinding **F** (2)

2.3 Beskou verbinding **B** en skryf neer die:

2.3.1 Homoloë reeks waaraan dit behoort (1)

2.3.2 Struktuurformule (2)

2.3.3 Algemene formule (1)

[10]



VRAAG 3 (Begin op 'n nuwe bladsy.)

Die grafiek hieronder toon die verhouding tussen dampdruk en temperatuur vir drie reguitketting-alkane (**A**, **B** en **C**). Die atmosferiese druk is 101,3 kPa.

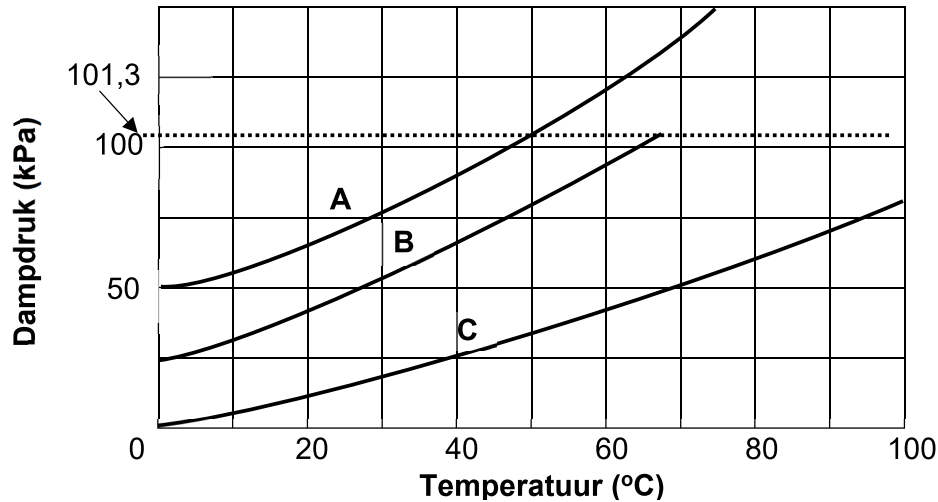

- 3.1 Definieer die term *dampdruk*. (2)
- 3.2 Gebruik die inligting in die grafiek hierbo om die volgende vrae te beantwoord.
- 3.2.1 Hoe beïnvloed 'n toename in temperatuur die dampdruk? Skryf slegs NEEM TOE, NEEM AF of GEEN EFFEK NIE neer. (1)
- 3.2.2 Watter verbinding het 'n kookpunt van ongeveer 68 °C? (1)
- 3.2.3 Gee 'n rede vir die antwoord op VRAAG 3.2.2. (2)
- 3.2.4 Watter verbinding het die langste kettinglengte? (3)
- Verduidelik die antwoord deur na die DAMPDRUK en RELATIEWE STERKTE VAN DIE INTERMOLEKULÊRE KRAGTE van die verbindings te verwys. (3)

[9]

VRAAG 4 (Begin op 'n nuwe bladsy.)

Bestudeer organiese reaksies **W**, **X**, **Y** en **Z** in die vloeiagram hieronder en beantwoord die vrae wat daarop volg.

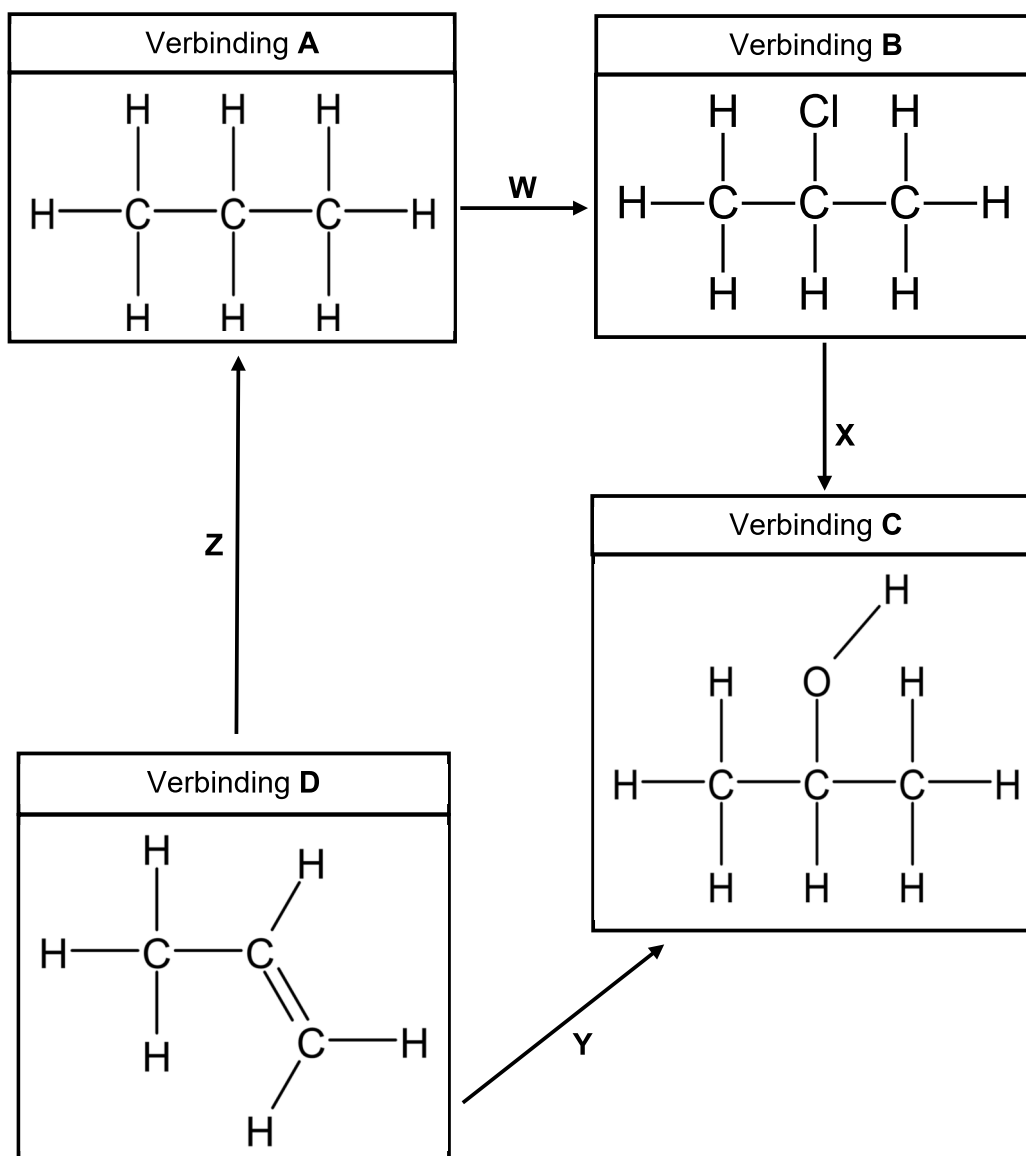

4.1 Vir reaksie **Y**, skryf neer:

4.1.1 Die NAAM van die reaksie (1)

4.1.2 TWEE toestande wat vir hierdie reaksie benodig word (2)

4.2 Identifiseer die tipe reaksie **Z**. (1)

- 4.3 Skryf die CHEMIESE FORMULE neer vir die stof wat met verbinding **A** reageer om verbinding **B** te vorm. (1)
- 4.4 Skryf die NAAM van reaksie **X** neer. (1)
- 4.5 Beskou die organiese verbindings in die lys hieronder.

Propan-2-ol	Propanaal	Propanoësuur	Propanoon
-------------	-----------	--------------	-----------

- 4.5.1 Identifiseer TWEE verbindings wat funksionele isomere is in die lys hierbo. (2)
- 4.5.2 Verduidelik en gebruik STRUKTUURFORMULES om die antwoord op VRAAG 4.5.1 te staaf. Benoem elke struktuurformule. (4)
- 4.6 Definieer die term *polimeer*. (2)
- 4.7 Teken die struktuurformule van die monomeer wat tydens die vervaardiging van die polimeer hieronder gebruik is.

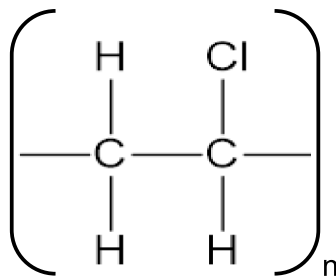

(2)
[16]



VRAAG 5 (Begin op 'n nuwe bladsy.)

Bestudeer die diagram hieronder en beantwoord die vrae wat volg.

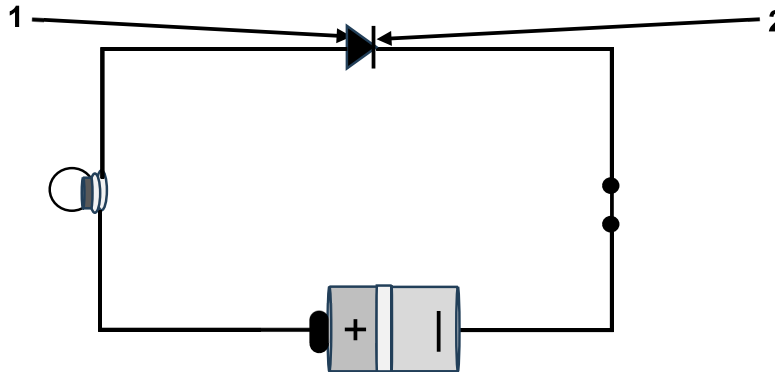

- 5.1 Benoem deel 1. (1)
- 5.2 Watter tipe p-n-voegvlakdiode is dit? Skryf slegs MEEVOORSPANNING of TEENVOORSPANNING of NULVOORSPANNING neer. (1)
- 5.3 Gee 'n rede vir die antwoord op VRAAG 5.2. (2)
- 5.4 Skryf TWEE eienskappe van die p-n-voegvlakdiode in VRAAG 5.2 neer. (2)
- [6]**



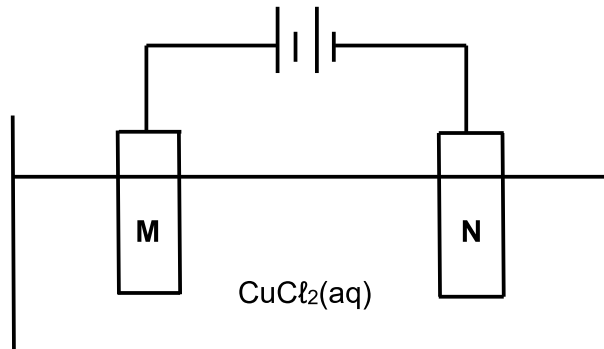

VRAAG 6 (Begin op 'n nuwe bladsy.)

Die diagram hieronder verteenwoordig 'n elektrolitiese sel wat in die ontbinding van 'n koper(II)chloriedoplossing gebruik word.

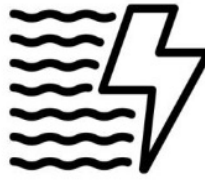

- 6.1 Definieer die term *elektroliet*. (2)
- 6.2 Watter elektrode, **M** of **N**, is die anode? (1)
- 6.3 Skryf die halfreaksie neer wat by elektrode **M** plaasvind. (2)
- 6.4 Skryf neer die:
- 6.4.1 Chemiese formule van die stof wat by elektrode **N** vorm (1)
- 6.4.2 Naam van die oksideermiddel in hierdie reaksie (1)

- 6.5 Beskou die vorme van alternatiewe energiebronne in die tabel hieronder en beantwoord die vrae wat volg.

	TIPE ENERGIË	DIAGRAM
A	Windenergie	
B	Sonligenergie	
C	Hidroëlektriese energie	
D	Biodiesel	

- 6.5.1 Noem EEN voordeel van alternatiewe energie. (1)
- 6.5.2 Skryf die letter neer van die energiebron wat met die werking van 'n fotovoltaïese sel verbind word. (1)
- 6.5.3 Skryf die energie-omskakeling neer wat plaasvind in die sel waarna in VRAAG 6.5.2 verwys is. (1)
- 6.5.4 Wat is *biodiesel*? (2)
- [12]**

VRAAG 7 (Begin op 'n nuwe bladsy.)

Die tabel hieronder toon halfsel **A** en 'n onbekende halfsel **B** wat gebruik is om 'n galvaniese sel onder standaardtoestande op te stel.

Halfsel A	$\text{Ni}^{2+}(\text{aq})/\text{Ni}(\text{s})$
Halfsel B	Onbekend

Die aanvanklike emk-lesing van die sel is 0,17 V wanneer dit in werking is en die polariteit van halfsel **B** is NEGATIEF.

- 7.1 Definieer die term *reduksie* in terme van elektronoordrag. (2)
- 7.2 Gebruik 'n berekening om die elektrode in halfsel **B** te identifiseer. (5)
- 7.3 Vir hierdie sel, skryf neer die:
- 7.3.1 Halfreaksie vir halfsel **A** (2)
- 7.3.2 Selnotasie (3)
- [12]**

TOTAAL: 75



**DATA FOR TECHNICAL SCIENCES GRADE 12
PAPER 2
GEGEWENS VIR TEGNIESE WETENSKAPPE GRAAD 12
VRAESTEL 2**

TABLE 1/TABEL 1: PHYSICAL CONSTANTS/FISIESE KONSTANTES

NAME/NAAM	SYMBOL/SIMBOOL	VALUE/WAARDE
Standard pressure <i>Standaarddruk</i>	p^{θ}	$1,01 \times 10^5 \text{ Pa}$
Standard temperature <i>Standaardtemperatuur</i>	T^{θ}	$0 \text{ }^{\circ}\text{C}/273 \text{ K}$

TABLE 2/TABEL 2: FORMULAE/FORMULES

Emf/Emk	$E^{\theta}_{\text{cell}} = E^{\theta}_{\text{cathode}} - E^{\theta}_{\text{anode}} \quad / \quad E^{\theta}_{\text{sel}} = E^{\theta}_{\text{katode}} - E^{\theta}_{\text{anode}}$ <i>or/of</i> $E^{\theta}_{\text{cell}} = E^{\theta}_{\text{reduction}} - E^{\theta}_{\text{oxidation}} \quad / \quad E^{\theta}_{\text{sel}} = E^{\theta}_{\text{reduksie}} - E^{\theta}_{\text{oksidasie}}$ <i>or/of</i> $E^{\theta}_{\text{cell}} = E^{\theta}_{\text{oxidising agent}} - E^{\theta}_{\text{reducing agent}} \quad / \quad E^{\theta}_{\text{sel}} = E^{\theta}_{\text{oksideermiddel}} - E^{\theta}_{\text{reduseermiddel}}$
---------	---



TABLE 3: THE PERIODIC TABLE OF ELEMENTS/TABEL 3: DIE PERIODIEKE TABEL VAN ELEMENTE

1	2	3	4	5	6	7	8	9	10	11	12	13	14	15	16	17	18	
(I)	(II)											(III)	(IV)	(V)	(VI)	(VII)	(VIII)	
KEY/SLEUTEL		Atomic number Atoomgetal																
Electronegativity Elektronegatiwiteit		Approximate relative atomic mass Benaderde relatiewe atoommassa																
1 H 1,01	2 He 4,00	3 Li 6,94	4 Be 9,01	5 B 10,81	6 C 12,01	7 N 14,01	8 O 15,99	9 F 18,99	10 Ne 20,18	11 Na 22,99	12 Mg 24,31	13 Al 26,98	14 Si 28,09	15 P 30,97	16 S 32,06	17 Cl 35,45	18 Ar 39,94	
19 K 39,09	20 Ca 40,08	21 Sc 44,96	22 Ti 47,88	23 V 50,94	24 Cr 51,99	25 Mn 54,94	26 Fe 55,85	27 Co 58,93	28 Ni 58,69	29 Cu 63,55	30 Zn 65,38	31 Ga 69,72	32 Ge 72,64	33 As 74,92	34 Se 78,96	35 Br 79,90	36 Kr 83,80	
37 Rb 85,47	38 Sr 87,62	39 Y 88,91	40 Zr 91,22	41 Nb 92,91	42 Mo 95,94	43 Tc 98,91	44 Ru 101,07	45 Rh 102,91	46 Pd 106,42	47 Ag 107,87	48 Cd 112,41	49 In 114,82	50 Sn 118,71	51 Sb 121,76	52 Te 127,60	53 I 126,90	54 Xe 131,29	
55 Cs 132,91	56 Ba 137,33	57 La 138,91	58 Ce 140,12	59 Pr 140,91	60 Nd 144,24	61 Pm 144,91	62 Sm 150,36	63 Eu 151,96	64 Gd 157,25	65 Tb 158,93	66 Dy 162,50	67 Ho 164,93	68 Er 167,26	69 Tm 168,93	70 Yb 173,05	71 Lu 174,97		
87 Fr 223,02	88 Ra 226,02	89 Ac 227,03	90 Th 232,04	91 Pa 231,04	92 U 238,03	93 Np 237,05	94 Pu 244,06	95 Am 243,06	96 Cm 247,07	97 Bk 247,07	98 Cf 251,08	99 Es 252,08	100 Fm 257,09	101 Md 258,10	102 No 259,10	103 Lr 260,10		

TABLE 4A: STANDARD REDUCTION POTENTIALS
TABEL 4A: STANDAARD-REDUKSIEPOTENSIALE

Half-reactions/ <i>Halfreaksies</i>	E^{\ominus} (V)
$F_2(g) + 2e^- \rightleftharpoons 2F^-$	+ 2,87
$Co^{3+} + e^- \rightleftharpoons Co^{2+}$	+ 1,81
$H_2O_2 + 2H^+ + 2e^- \rightleftharpoons 2H_2O$	+1,77
$MnO_4^- + 8H^+ + 5e^- \rightleftharpoons Mn^{2+} + 4H_2O$	+ 1,51
$Cl_2(g) + 2e^- \rightleftharpoons 2Cl^-$	+ 1,36
$Cr_2O_7^{2-} + 14H^+ + 6e^- \rightleftharpoons 2Cr^{3+} + 7H_2O$	+ 1,33
$O_2(g) + 4H^+ + 4e^- \rightleftharpoons 2H_2O$	+ 1,23
$MnO_2 + 4H^+ + 2e^- \rightleftharpoons Mn^{2+} + 2H_2O$	+ 1,23
$Pt^{2+} + 2e^- \rightleftharpoons Pt$	+ 1,20
$Br_2(l) + 2e^- \rightleftharpoons 2Br^-$	+ 1,07
$NO_3^- + 4H^+ + 3e^- \rightleftharpoons NO(g) + 2H_2O$	+ 0,96
$Hg^{2+} + 2e^- \rightleftharpoons Hg(l)$	+ 0,85
$Ag^+ + e^- \rightleftharpoons Ag$	+ 0,80
$NO_3^- + 2H^+ + e^- \rightleftharpoons NO_2(g) + H_2O$	+ 0,80
$Fe^{3+} + e^- \rightleftharpoons Fe^{2+}$	+ 0,77
$O_2(g) + 2H^+ + 2e^- \rightleftharpoons H_2O_2$	+ 0,68
$I_2 + 2e^- \rightleftharpoons 2I^-$	+ 0,54
$Cu^+ + e^- \rightleftharpoons Cu$	+ 0,52
$SO_2 + 4H^+ + 4e^- \rightleftharpoons S + 2H_2O$	+ 0,45
$2H_2O + O_2 + 4e^- \rightleftharpoons 4OH^-$	+ 0,40
$Cu^{2+} + 2e^- \rightleftharpoons Cu$	+ 0,34
$SO_4^{2-} + 4H^+ + 2e^- \rightleftharpoons SO_2(g) + 2H_2O$	+ 0,17
$Cu^{2+} + e^- \rightleftharpoons Cu^+$	+ 0,16
$Sn^{4+} + 2e^- \rightleftharpoons Sn^{2+}$	+ 0,15
$S + 2H^+ + 2e^- \rightleftharpoons H_2S(g)$	+ 0,14
$2H^+ + 2e^- \rightleftharpoons H_2(g)$	0,00
$Fe^{3+} + 3e^- \rightleftharpoons Fe$	- 0,06
$Pb^{2+} + 2e^- \rightleftharpoons Pb$	- 0,13
$Sn^{2+} + 2e^- \rightleftharpoons Sn$	- 0,14
$Ni^{2+} + 2e^- \rightleftharpoons Ni$	- 0,27
$Co^{2+} + 2e^- \rightleftharpoons Co$	- 0,28
$Cd^{2+} + 2e^- \rightleftharpoons Cd$	- 0,40
$Cr^{3+} + e^- \rightleftharpoons Cr^{2+}$	- 0,41
$Fe^{2+} + 2e^- \rightleftharpoons Fe$	- 0,44
$Cr^{3+} + 3e^- \rightleftharpoons Cr$	- 0,74
$Zn^{2+} + 2e^- \rightleftharpoons Zn$	- 0,76
$2H_2O + 2e^- \rightleftharpoons H_2(g) + 2OH^-$	- 0,83
$Cr^{2+} + 2e^- \rightleftharpoons Cr$	- 0,91
$Mn^{2+} + 2e^- \rightleftharpoons Mn$	- 1,18
$Al^{3+} + 3e^- \rightleftharpoons Al$	- 1,66
$Mg^{2+} + 2e^- \rightleftharpoons Mg$	- 2,36
$Na^+ + e^- \rightleftharpoons Na$	- 2,71
$Ca^{2+} + 2e^- \rightleftharpoons Ca$	- 2,87
$Sr^{2+} + 2e^- \rightleftharpoons Sr$	- 2,89
$Ba^{2+} + 2e^- \rightleftharpoons Ba$	- 2,90
$Cs^+ + e^- \rightleftharpoons Cs$	- 2,92
$K^+ + e^- \rightleftharpoons K$	- 2,93
$Li^+ + e^- \rightleftharpoons Li$	- 3,05

Increasing strength of oxidising agents/*Toenemende sterkte van oksideermiddels*

Increasing strength of reducing agents/*Toenemende sterkte van reduseermiddels*



TABLE 4B: STANDARD REDUCTION POTENTIALS
TABEL 4B: STANDAARD-REDUKSIEPOTENSIALE

Half-reactions/ <i>Halfreaksies</i>		E^{\ominus} (V)
$\text{Li}^+ + \text{e}^-$	\rightleftharpoons Li	- 3,05
$\text{K}^+ + \text{e}^-$	\rightleftharpoons K	- 2,93
$\text{Cs}^+ + \text{e}^-$	\rightleftharpoons Cs	- 2,92
$\text{Ba}^{2+} + 2\text{e}^-$	\rightleftharpoons Ba	- 2,90
$\text{Sr}^{2+} + 2\text{e}^-$	\rightleftharpoons Sr	- 2,89
$\text{Ca}^{2+} + 2\text{e}^-$	\rightleftharpoons Ca	- 2,87
$\text{Na}^+ + \text{e}^-$	\rightleftharpoons Na	- 2,71
$\text{Mg}^{2+} + 2\text{e}^-$	\rightleftharpoons Mg	- 2,36
$\text{Al}^{3+} + 3\text{e}^-$	\rightleftharpoons Al	- 1,66
$\text{Mn}^{2+} + 2\text{e}^-$	\rightleftharpoons Mn	- 1,18
$\text{Cr}^{2+} + 2\text{e}^-$	\rightleftharpoons Cr	- 0,91
$2\text{H}_2\text{O} + 2\text{e}^-$	\rightleftharpoons $\text{H}_2(\text{g}) + 2\text{OH}^-$	- 0,83
$\text{Zn}^{2+} + 2\text{e}^-$	\rightleftharpoons Zn	- 0,76
$\text{Cr}^{3+} + 3\text{e}^-$	\rightleftharpoons Cr	- 0,74
$\text{Fe}^{2+} + 2\text{e}^-$	\rightleftharpoons Fe	- 0,44
$\text{Cr}^{3+} + \text{e}^-$	\rightleftharpoons Cr^{2+}	- 0,41
$\text{Cd}^{2+} + 2\text{e}^-$	\rightleftharpoons Cd	- 0,40
$\text{Co}^{2+} + 2\text{e}^-$	\rightleftharpoons Co	- 0,28
$\text{Ni}^{2+} + 2\text{e}^-$	\rightleftharpoons Ni	- 0,27
$\text{Sn}^{2+} + 2\text{e}^-$	\rightleftharpoons Sn	- 0,14
$\text{Pb}^{2+} + 2\text{e}^-$	\rightleftharpoons Pb	- 0,13
$\text{Fe}^{3+} + 3\text{e}^-$	\rightleftharpoons Fe	- 0,06
$2\text{H}^+ + 2\text{e}^-$	\rightleftharpoons $\text{H}_2(\text{g})$	0,00
$\text{S} + 2\text{H}^+ + 2\text{e}^-$	\rightleftharpoons $\text{H}_2\text{S}(\text{g})$	+ 0,14
$\text{Sn}^{4+} + 2\text{e}^-$	\rightleftharpoons Sn^{2+}	+ 0,15
$\text{Cu}^{2+} + \text{e}^-$	\rightleftharpoons Cu^+	+ 0,16
$\text{SO}_4^{2-} + 4\text{H}^+ + 2\text{e}^-$	\rightleftharpoons $\text{SO}_2(\text{g}) + 2\text{H}_2\text{O}$	+ 0,17
$\text{Cu}^{2+} + 2\text{e}^-$	\rightleftharpoons Cu	+ 0,34
$2\text{H}_2\text{O} + \text{O}_2 + 4\text{e}^-$	\rightleftharpoons 4OH^-	+ 0,40
$\text{SO}_2 + 4\text{H}^+ + 4\text{e}^-$	\rightleftharpoons S + $2\text{H}_2\text{O}$	+ 0,45
$\text{Cu}^+ + \text{e}^-$	\rightleftharpoons Cu	+ 0,52
$\text{I}_2 + 2\text{e}^-$	\rightleftharpoons 2I^-	+ 0,54
$\text{O}_2(\text{g}) + 2\text{H}^+ + 2\text{e}^-$	\rightleftharpoons H_2O_2	+ 0,68
$\text{Fe}^{3+} + \text{e}^-$	\rightleftharpoons Fe^{2+}	+ 0,77
$\text{NO}_3^- + 2\text{H}^+ + \text{e}^-$	\rightleftharpoons $\text{NO}_2(\text{g}) + \text{H}_2\text{O}$	+ 0,80
$\text{Ag}^+ + \text{e}^-$	\rightleftharpoons Ag	+ 0,80
$\text{Hg}^{2+} + 2\text{e}^-$	\rightleftharpoons $\text{Hg}(\ell)$	+ 0,85
$\text{NO}_3^- + 4\text{H}^+ + 3\text{e}^-$	\rightleftharpoons $\text{NO}(\text{g}) + 2\text{H}_2\text{O}$	+ 0,96
$\text{Br}_2(\ell) + 2\text{e}^-$	\rightleftharpoons 2Br^-	+ 1,07
$\text{Pt}^{2+} + 2\text{e}^-$	\rightleftharpoons Pt	+ 1,20
$\text{MnO}_2 + 4\text{H}^+ + 2\text{e}^-$	\rightleftharpoons $\text{Mn}^{2+} + 2\text{H}_2\text{O}$	+ 1,23
$\text{O}_2(\text{g}) + 4\text{H}^+ + 4\text{e}^-$	\rightleftharpoons $2\text{H}_2\text{O}$	+ 1,23
$\text{Cr}_2\text{O}_7^{2-} + 14\text{H}^+ + 6\text{e}^-$	\rightleftharpoons $2\text{Cr}^{3+} + 7\text{H}_2\text{O}$	+ 1,33
$\text{Cl}_2(\text{g}) + 2\text{e}^-$	\rightleftharpoons 2Cl^-	+ 1,36
$\text{MnO}_4^- + 8\text{H}^+ + 5\text{e}^-$	\rightleftharpoons $\text{Mn}^{2+} + 4\text{H}_2\text{O}$	+ 1,51
$\text{H}_2\text{O}_2 + 2\text{H}^+ + 2\text{e}^-$	\rightleftharpoons $2\text{H}_2\text{O}$	+ 1,77
$\text{Co}^{3+} + \text{e}^-$	\rightleftharpoons Co^{2+}	+ 1,81
$\text{F}_2(\text{g}) + 2\text{e}^-$	\rightleftharpoons 2F^-	+ 2,87

Increasing strength of oxidising agents/*Toenemende sterkte van oksideermiddels*

Increasing strength of reducing agents/*Toenemende sterkte van reduseermiddels*

