

SA EXAM PAPERS This Paper was downloaded from SAEXAMPAPERS
SA's Leading Past Year

Exam Paper Portal



You have Downloaded, yet Another Great Resource to assist you with your Studies 😊

Thank You for Supporting SA Exam Papers

Your Leading Past Year Exam Paper Resource Portal

Visit us @ www.saexampapers.co.za



**SA EXAM
PAPERS**

SA EXAM PAPERS

Proudly South African



This Paper was downloaded from SAEXAMPAPERS

GAUTENG PROVINCE

EDUCATION
REPUBLIC OF SOUTH AFRICA

**JUNE EXAMINATION
GRADE 12**

2026

PHYSICAL SCIENCES (PHYSICS)

(PAPER 1)

PHYSICAL SCIENCES P1



C2841E

TIME: 3 hours

MARKS: 150

18 pages + 3 data sheets

X05



SA EXAM PAPERS

Proudly South African

**INSTRUCTIONS AND INFORMATION**

1. This question paper consists of 10 questions. Answer ALL the questions in the ANSWER BOOK.
2. Start EACH question on a NEW page in the ANSWER BOOK.
3. Number the answers correctly according to the numbering system used in this question paper.
4. Leave ONE line open between two subsections, e.g. between QUESTION 2.1 and QUESTION 2.2.
5. You may use a non-programmable calculator.
6. You may use appropriate mathematical instruments.
7. You are advised to use the attached DATA SHEETS.
8. Show ALL formulae and substitutions in ALL calculations.
9. Round-off your FINAL numerical answers to a minimum of TWO decimal places.
10. Give brief motivations, discussions, etc. where required.
11. Write neatly and legibly.

**SA EXAM PAPERS**

Proudly South African

QUESTION 1: MULTIPLE-CHOICE QUESTIONS

Various options are provided as possible answers to the following questions. Each question has only ONE correct answer. Choose the answer and write only the letter (A – D) next to the question numbers (1.1 to 1.10) in the ANSWER BOOK, e.g. 1.11 E.

- 1.1 Two objects of equal mass move towards each other at the same speed. Object **A** moves to the right and collides with object **B** which is moving to the left. Both objects stop immediately after the collision. Ignore the effects of friction.

Which of the following statements is INCORRECT during the collision?

- A The force exerted by object **A** is equal to the force exerted by object **B**.
 B The total linear momentum is conserved.
 C The collision is inelastic.
 D The magnitude of the impulse of object **A** is equal to the magnitude of the impulse of object **B**.

(2)

- 1.2 Two objects, object **X** and object **Y**, of equal mass move towards each other due to their gravitational force of attraction.



Which of the combinations below is CORRECT for the acceleration of the objects towards each other and the gravitational force between them?

	ACCELERATION	GRAVITATIONAL FORCE
A	Decreases	Remains the same
B	Increases	Remains the same
C	Remains the same	Increases
D	Increases	Increases

(2)



- 1.3 The velocity-time graph below represents the movement of an object starting with an initial velocity v and moving under the influence of gravitational force only. The graph is not drawn to scale.

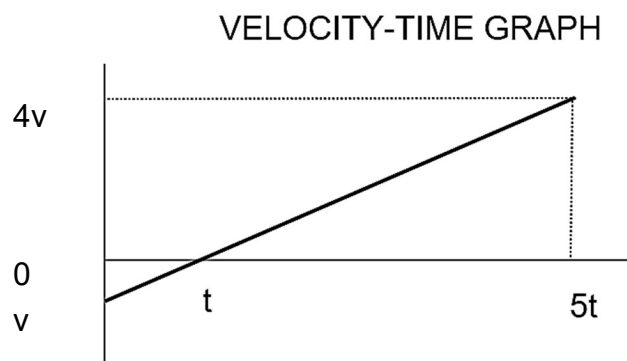

The distance that the object travels in the time $5t$ is:

- A $v t$
- B $\frac{15}{2} v t$
- C $\frac{17}{2} v t$
- D $\frac{21}{2} v t$

(2)



- 1.4 A person of mass M is moving to the left on a skateboard of mass m . The initial velocity of the person and the skateboard is v . The person then jumps off the skateboard and is stationary while the skateboard continues to move to the left.



Which of the following expressions can be used to CORRECTLY calculate the speed of the skateboard after the person jumps off?

- A $(M+m)v - m$
- B $\frac{Mv + mv}{m}$
- C $\frac{mv}{M + m}$
- D $\frac{(M - m)v}{m}$ (2)

- 1.5 An apple falls from a tree. Which of the following statements about the falling apple is TRUE? Ignore all effects of air friction.

- A Total momentum is conserved.
- B Total kinetic energy is conserved.
- C The total mechanical energy is conserved.
- D The gravitational potential energy is conserved. (2)

- 1.6 An ambulance moves towards a stationary listener at a constant speed while emitting soundwaves with a wavelength of 0,72 m.

The wavelength of a soundwave observed by the listener becomes ...

- A larger than 0,72 m.
- B smaller than 0,72 m.
- C equal to 0,72 m.
- D larger and then zero. (2)



1.7 In which graph below can the gradient be used to calculate Coulomb's constant?

A

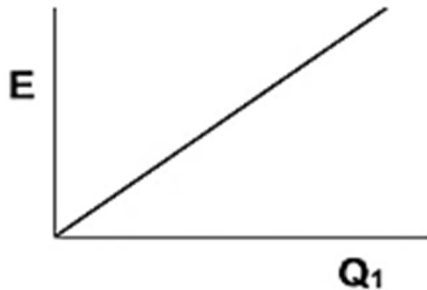

B

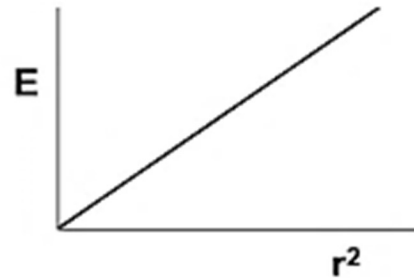

C

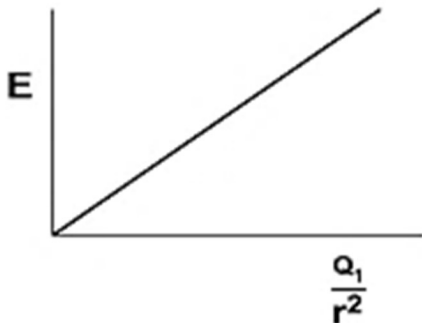

D

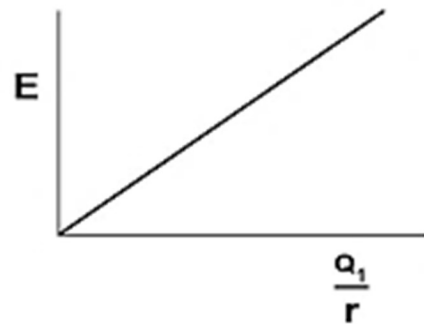

(2)

1.8 Two charges of $+2 \text{ nC}$ and -2 nC are placed on a straight line. **S** and **T** are two points that are on the same straight line as shown in the diagram below.

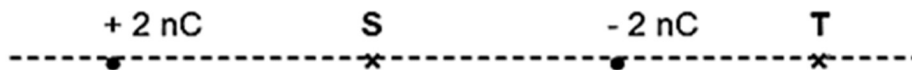

Which of the following represents the directions of the resultant electric field at **S** and **T** CORRECTLY?

	Direction of the resultant electric field at point S	Direction of the resultant electric field at point T
A	Right	Left
B	Left	Left
C	Right	Right
D	Left	Right

(2)



SA EXAM PAPERS

Proudly South African

- 1.9 A learner conducts an experiment by measuring the potential difference and current that flows through three different copper wires, representing the results on graphs **X**, **Y** and **Z** as shown below.

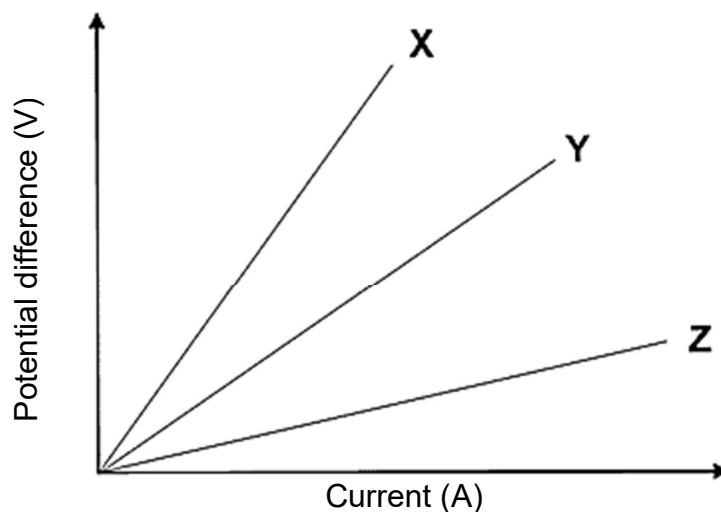

Which of the following is TRUE?

Resistance of:

- A $X > Y > Z$
- B $X = Y = Z$
- C $Y > X > Z$
- D $Z > Y > X$

(2)



SA EXAM PAPERS

Proudly South African

PHYSICAL SCIENCES

(PAPER 1)

- 1.10 In the circuit diagram below, R_x and R_y are identical ohmic resistors that are connected in parallel. When the switch is open, the ammeter reading is 0,1 A and the voltmeter reading is 3 V. The battery has an unknown emf and internal resistance.

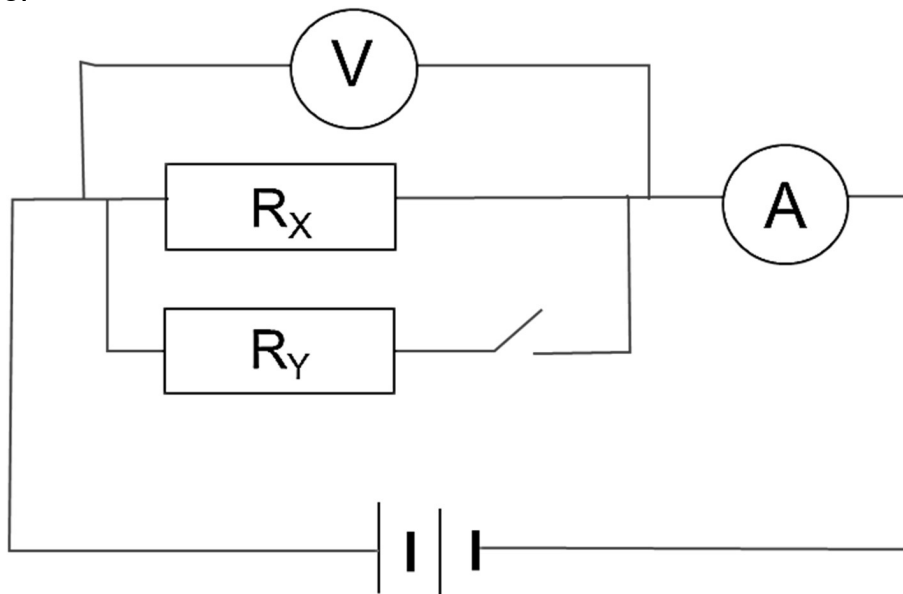

What is the reading on the AMMETER and the VOLTMETER when the switch is closed?

	READING ON AMMETER	READING ON VOLTMETER
A	Equal to 0,1 A	Equal to 3 V
B	Larger than 0,1 A	Equal to 3 V
C	Smaller than 0,1 A	Larger than 3 V
D	Larger than 0,1 A	Smaller than 3 V

(2)
[20]



SA EXAM PAPERS

Proudly South African

QUESTION 2 (Start on a new page.)

Block **A** of mass 6 kg is connected to block **B** with a mass of 1 kg by means of a light, inextensible rope over a frictionless pulley. Initially, both blocks are stationary. Block **B** is pulled vertically up with a force of 43 N. Block **A** accelerates to the left with a constant acceleration of $2 \text{ m}\cdot\text{s}^{-2}$ over a rough horizontal surface, as shown in the diagram below. Ignore the effects of air resistance.

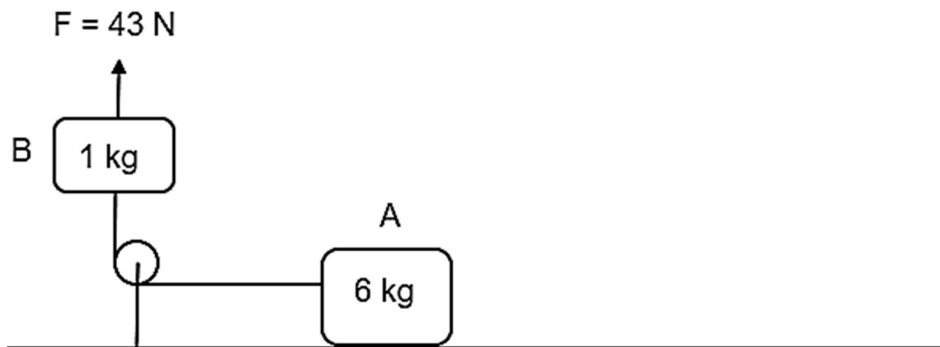

- 2.1 State *Newton's Second Law of Motion* in words. (2)
- 2.2 Draw a labelled free-body diagram, showing ALL the forces acting on block **B**. (3)
- 2.3 Calculate the magnitude of the:
- 2.3.1 Tension in the rope (4)
- 2.3.2 Coefficient of kinetic friction between block **A** and the surface (4)
- 2.4 The rope connecting the two blocks breaks and the 6 kg block slows down and stops after a certain time.

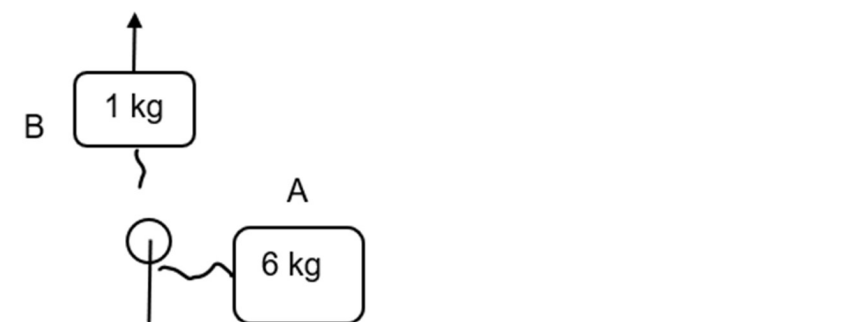

- 2.4.1 In which direction will the acceleration of the 6 kg block be? Choose between TO THE LEFT or TO THE RIGHT. (1)
- 2.4.2 Explain the answer to QUESTION 2.4.1. (2)



QUESTION 3 (Start on a new page.)

The planet Omega has a mass $6,4 \times 10^{23}$ kg. The diameter of planet Omega is equal to the radius of the Earth.

- 3.1 Describe the term *weight of an object*. (2)
- 3.2 A 90 kg object is dropped from a height of 2 m above the surface of Omega.
- 3.2.1 Calculate the magnitude of the gravitational acceleration on the surface of Omega. (4)
- 3.2.2 How long will it take the object to reach the surface of Omega compared to the time it would take on Earth? Write only SAME TIME, LESS TIME or MORE TIME. Give a reason for the answer. (2)
- 3.3 The 90 kg object was projected upwards so that the distance between the surface of Omega and the centre of the object is 2 360 000 m as shown in the diagram below.

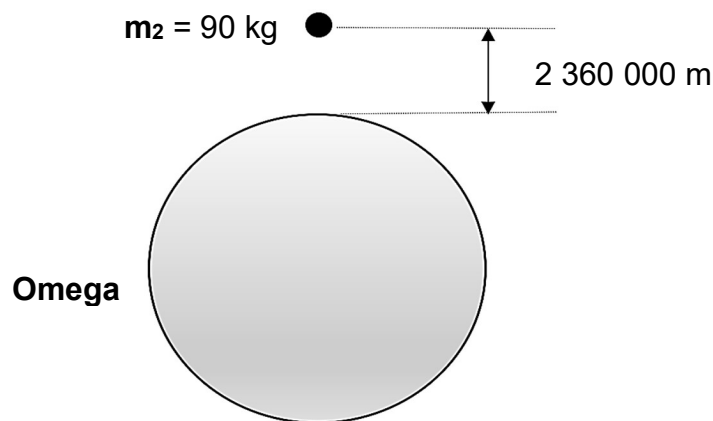

Calculate the gravitational force between Omega and the object at this distance. (5)



- 3.4 Two isolated bodies, **A** and **B**, with masses **M** and **3M** respectively, are placed a distance **2r** from each other's centres. The gravitational force between them is **F**. The diagram is not drawn to scale.

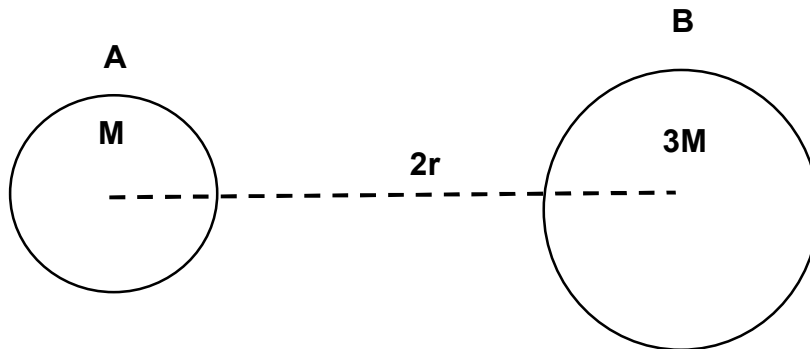

Determine the gravitational force between **A** and **B** in terms of **F** if the distance is increased to **6r**.

(2)
[15]

QUESTION 4 (Start on a new page.)

Ball **A** is dropped vertically downwards from the top of a high building with an unknown height **h**. ONE second later, another ball, **B**, is thrown vertically downwards from the same height with a speed of $20 \text{ m}\cdot\text{s}^{-1}$. Ball **B** passes ball **A** when the balls reach the top of the window. The top of the window is 3 m above the ground as shown in the diagram below. The diagram is not drawn to scale. Ignore the effects of friction.

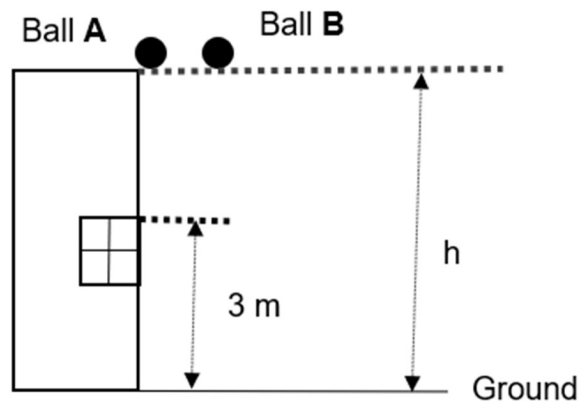

- 4.1 Define the term *free fall*. (2)
- 4.2 Use only equations of motion and calculate:
- 4.2.1 The velocity of ball **A** after falling for 2 seconds (3)
- 4.2.2 How long after ball **A** was dropped will ball **B** pass it (5)
- 4.2.3 The height of the building (4)



- 4.3 On the same set of axes, sketch the velocity-time graphs of the motion of ball **A** and ball **B** until they reach the ground. Label the graphs **A** and **B** respectively.

Clearly indicate the following on your graph:

- The initial velocities of both balls
- The times at which the balls reach the ground as t_1 for ball **A** and t_2 for ball **B** (4)

- 4.4 Ball **A** bounces and reaches a certain height above the window. The collision of the ball and the ground is elastic.

Sketch the position-time graph for ball **A** from the moment it was dropped until it reaches the top of the window AFTER the ball bounced from the ground. Take the ground as zero reference.

Clearly indicate the initial and final height of the ball on your graph:

(3)
[21]

QUESTION 5 (Start on a new page.)

A 4 kg metal object slides to the right at a constant speed of $7 \text{ m}\cdot\text{s}^{-1}$ and it collides with a 5 kg metal object moving towards it at the same speed. They collide at point **X**. The collision lasts 0,03 seconds after which they stick together and move in the same direction. Ignore the effects of friction.

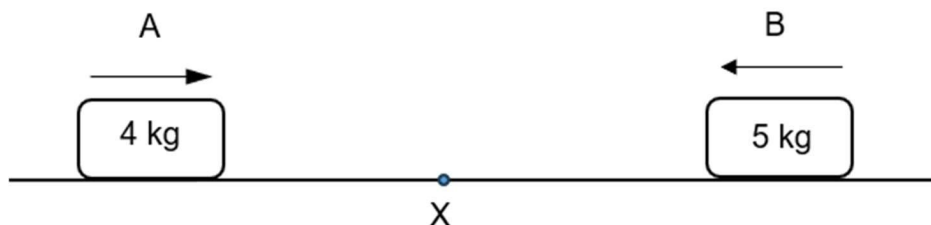

- 5.1 State *Newton's Second Law in terms of momentum* in words. (2)
- 5.2 Calculate the:
- 5.2.1 Velocity of the combined system after the collision (4)
- 5.2.2 Average net force that the 4 kg object exerts on the 5 kg object (4)
- 5.3 What would happen to the magnitude of the impulse if softer objects were used and the net force remains the same? Write only INCREASES, DECREASES or REMAINS THE SAME. Explain the answer. (3)

[13]



QUESTION 6 (Start on a new page.)

A person on a sandboard, with a combined mass of 62 kg, goes sandboarding down a sand dune in Boksburg, Mount Mayhem, South Africa. The person's velocity increases from $8,5 \text{ m}\cdot\text{s}^{-1}$ to $23,3 \text{ m}\cdot\text{s}^{-1}$ from point **A** to point **B**. The work done by friction from point **A** to point **B** is 8 700 J.

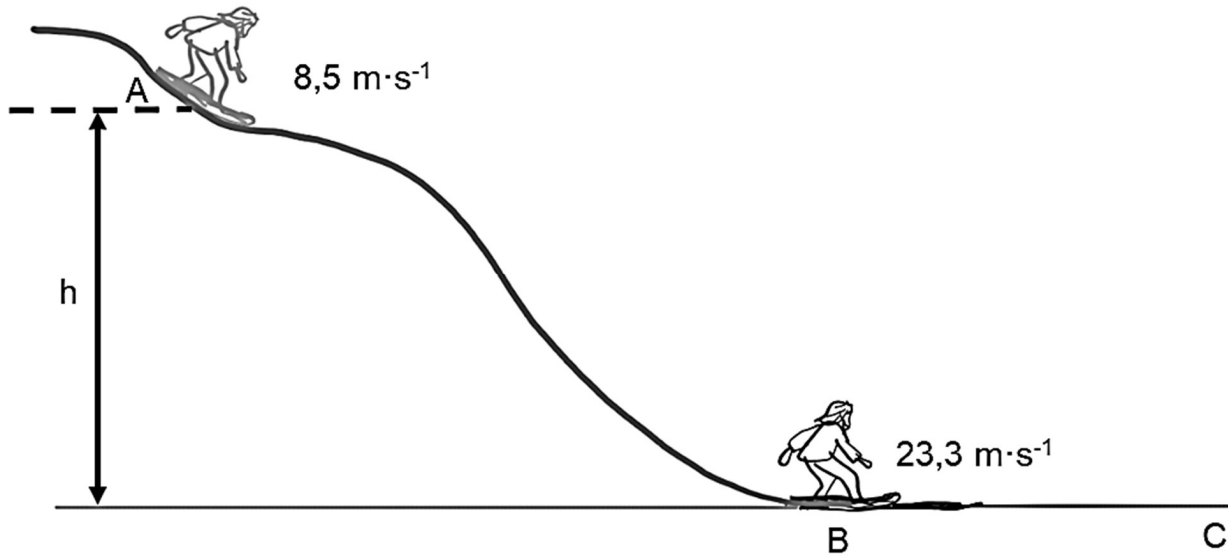

- 6.1 Define the term *non-conservative force*. (2)
- 6.2 Calculate the height at which the person starts, at point **A**, using ENERGY PRINCIPLES ONLY. (4)
- 6.3 Define the term *power*. (2)
- 6.4 Draw a free-body diagram of all the horizontal forces acting on the person while moving from point **B** to point **C**. (2)
- 6.5 The average power dissipated by the person until he stops, is 4 593,83 W. Calculate the average force experienced by the person during this motion. (3)
- [13]**



QUESTION 7 (Start on a new page.)

A group of grade 12 learners investigates the relationship between the RATIO of the observed frequency to the frequency of the source ($\frac{f_L}{f_S}$), and the velocity at which the listener moves relative to a stationary source.

The experiment is repeated by increasing the constant velocity at which the listener moves towards the same sound source.

The observed frequency (f_L) is recorded and the RATIO ($\frac{f_L}{f_S}$) for each experiment is calculated.

The graph below shows the results that were acquired.

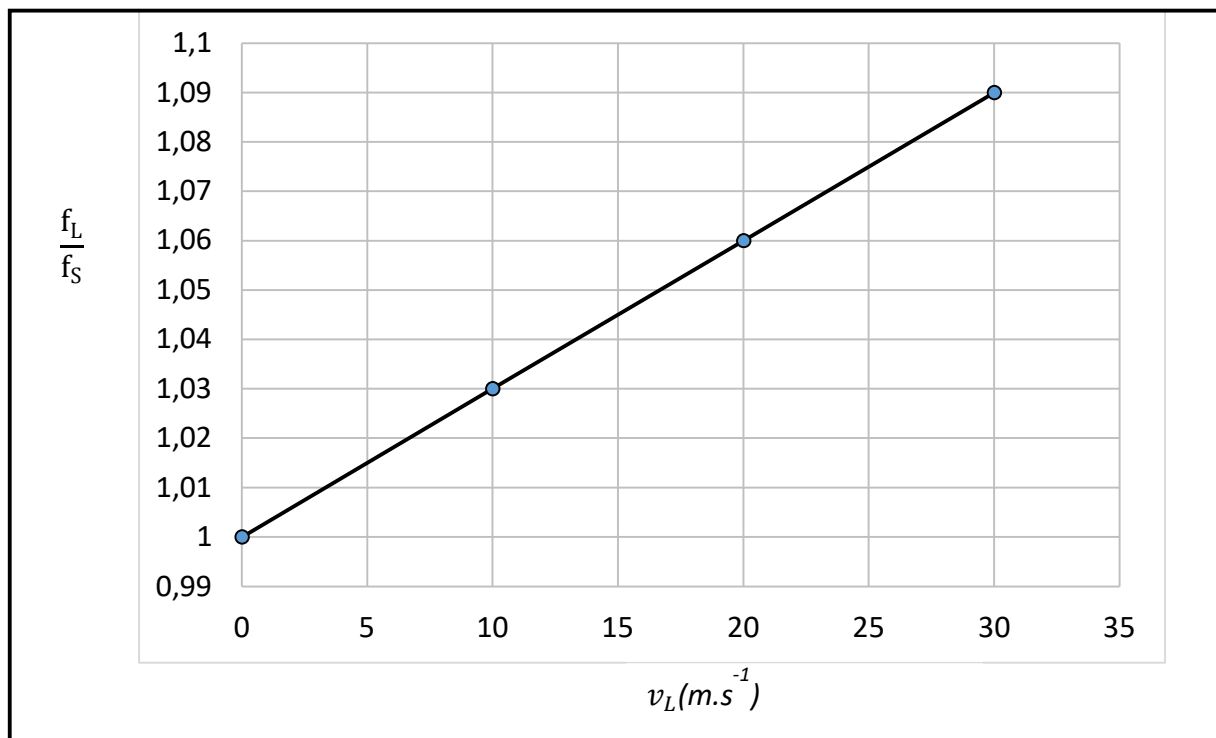

7.1 State the *Doppler effect* in words. (2)

Use the graph to answer the following questions.

7.2 Is the listener moving AWAY or TOWARDS the stationary source?
Give a reason for the answer. (2)

7.3 What physical quantity is represented by the gradient of this graph? (2)

7.4 Calculate the speed of sound in air. (4)

[10]



PHYSICAL SCIENCES

(PAPER 1)

QUESTION 8 (Start on a new page.)

Four pith balls are charged. Ball **A** and ball **D** have unknown charges. Ball **B** has a charge of $-2 \times 10^{-3} \text{ C}$ and ball **C** has a charge of $+2 \times 10^{-3} \text{ C}$. The effect of ball **A** when held above each of the isolated test tubes with each of the other charged pith balls, is shown in the diagram below.

- Ball **B** remains at the bottom of the test tube.
- Ball **C** moves up until it is 4 cm from ball **A**.
- Ball **D** moves up so that it is 2,4 cm from ball **A**.

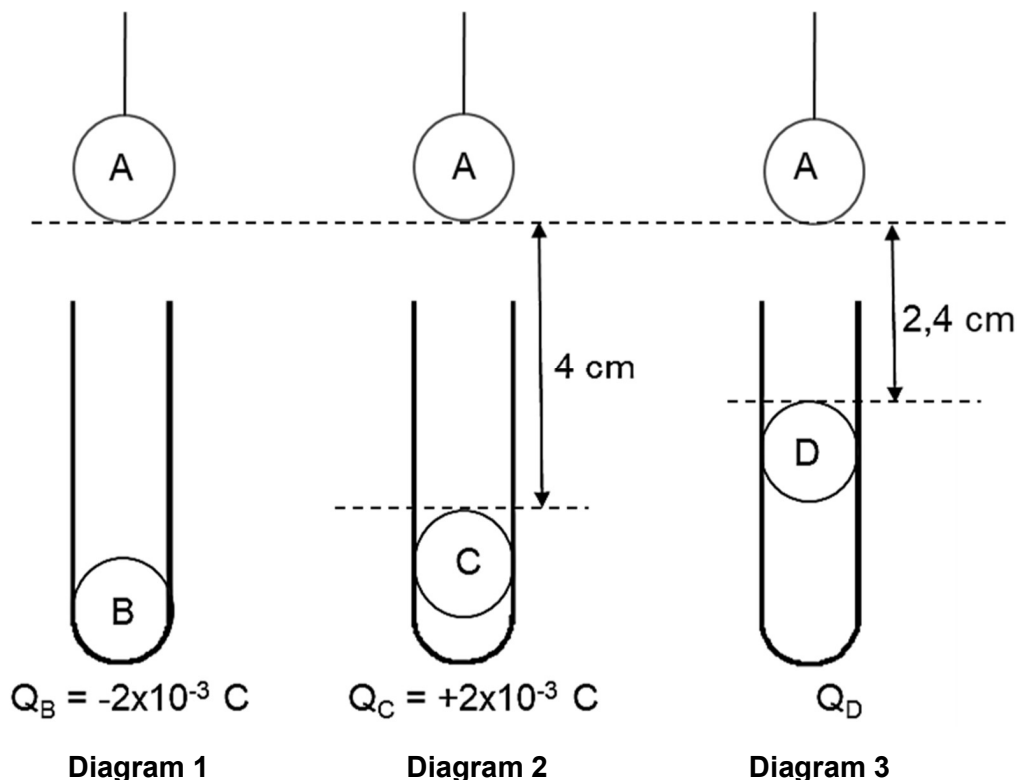

- 8.1 State *Coulomb's Law* in words. (2)
- 8.2 Identify the charge on ball **A** as POSITIVE or NEGATIVE. Explain the answer. (3)
- 8.3 Draw a free-body diagram of ALL the forces that are exerted on ball **A** in diagram 2. (3)
- 8.4 The net electrostatic force between ball **A** and ball **C** is F_{AC} . Calculate the charge on ball **D** if the force between **A** and **D** is the same as the force between **A** and **C**. (4)
- [12]**



SA EXAM PAPERS

Proudly South African

Please turn over

QUESTION 9 (Start on a new page.)

Two small, charged spheres, **R** and **S**, are placed 120 mm apart in a vacuum, as shown in the diagram below. Sphere **S** has $7,5 \times 10^{12}$ electrons in excess and sphere **R** has a charge of $+0,7 \mu\text{C}$.

Point **P** is 40 mm to the right of sphere **R**.

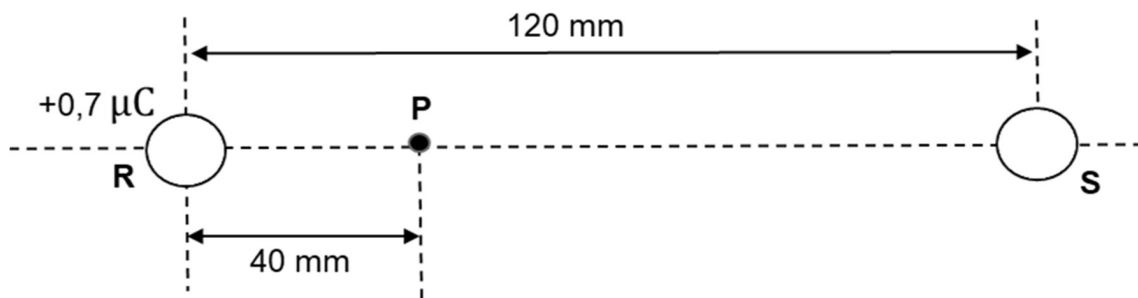

- 9.1 Define the term *electric field at a point*. (2)
- 9.2 Draw a diagram to show the net electric field pattern around the two spheres if they had the same magnitudes of charges. (3)
- 9.3 Calculate the:
- 9.3.1 Charge on sphere **S** (3)
- 9.3.2 Net electric field at point **P** (4)
- [12]**



QUESTION 10 (Start on a new page.)

- 10.1 A group of learners conduct an experiment to determine the emf and internal resistance of a battery by using the circuit below.

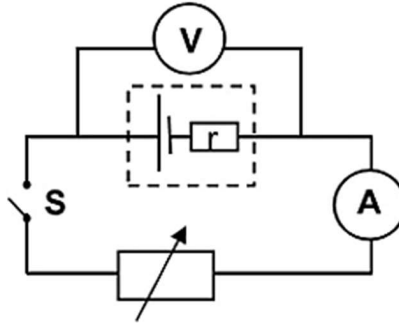

The learners draw the following potential difference versus current graph from the results acquired.

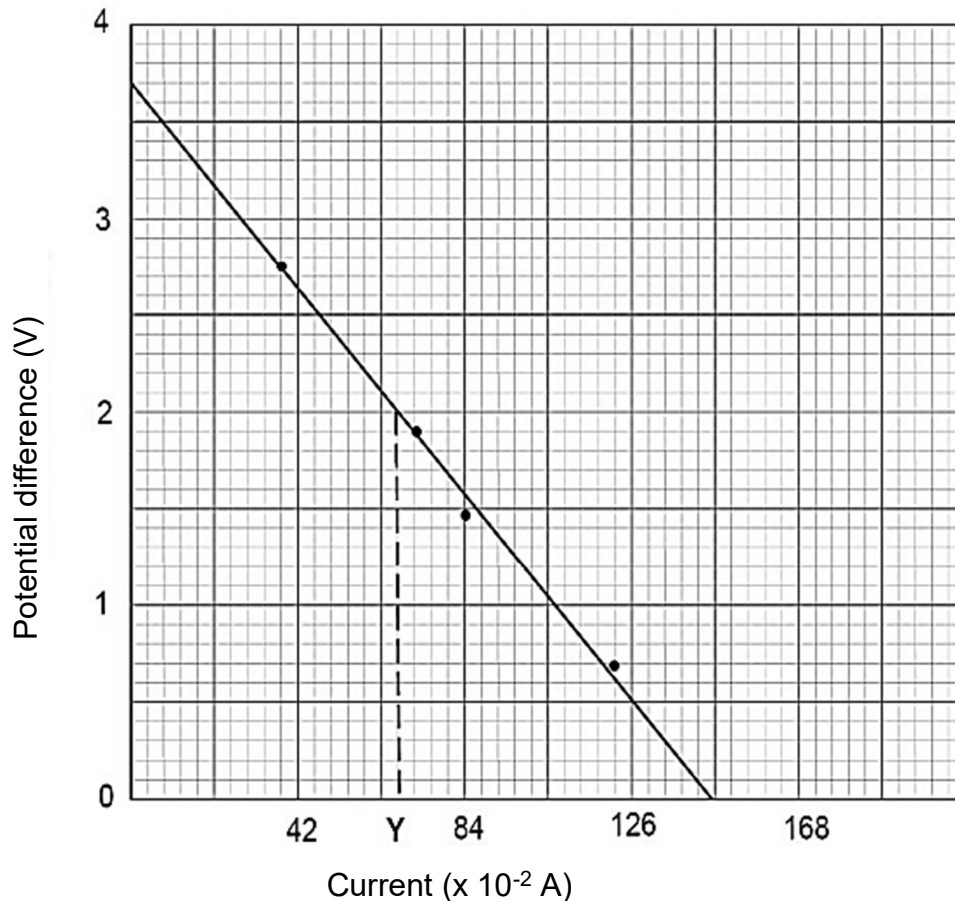

- 10.1.1 Give the value of the emf of the battery. (1)
- 10.1.2 Calculate the internal resistance of the battery. (3)
- 10.1.3 Determine the external resistance of the circuit when the ammeter reading is Y. (3)



- 10.2 In the circuit below there is a battery with UNKNOWN emf and an internal resistance of $0,5 \Omega$ connected to two resistors of 2Ω and 6Ω each as well as a resistor **R** with unknown resistance. Ignore the resistance of the connecting wires.

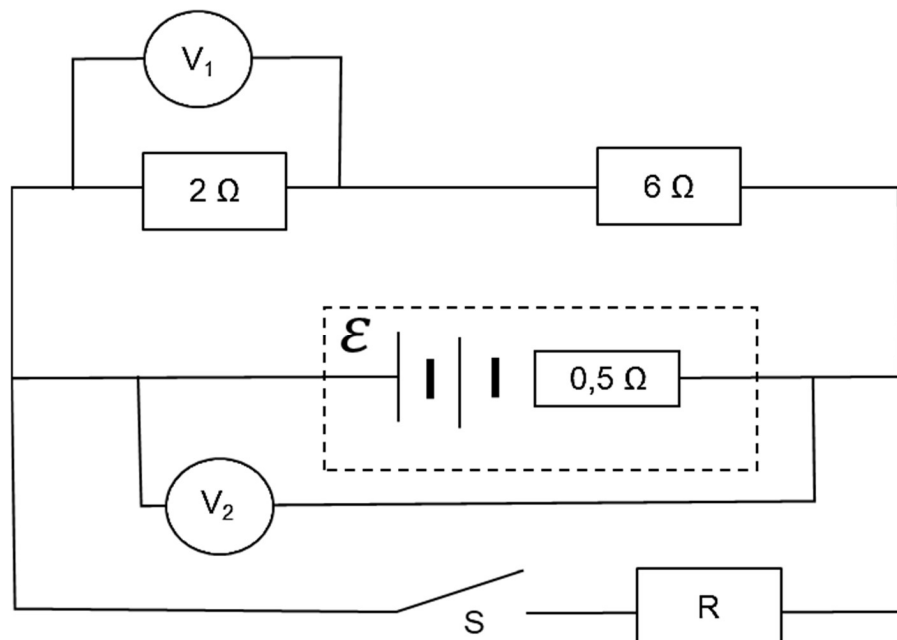

- 10.2.1 State *Ohm's Law* in words. (2)
- 10.2.2 Switch **S** is open. The reading on the voltmeter V_1 is 3 V. Calculate the emf of the battery. (4)
- 10.2.3 Switch **S** is closed. The reading on voltmeter V_2 is 10,25 V. Calculate the resistance of the resistor **R**. (5)

[18]

TOTAL: 150



SA EXAM PAPERS

Proudly South African

**DATA FOR PHYSICAL SCIENCES GRADE 12
PAPER 1 (PHYSICS)**

**GEGEWENS VIR FISIESTE WETENSKAPPE GRAAD 12
VRAESTEL 1 (FISIKA)**

TABLE 1: PHYSICAL CONSTANTS/TABEL 1: FISIESTE KONSTANTES

NAME/NAAM	SYMBOL/SIMBOOL	VALUE/WAARDE
Acceleration due to gravity <i>Swaartekragversnelling</i>	g	9,8 m·s ⁻²
Universal gravitational constant <i>Universele gravitasiekonstante</i>	G	6,67 x 10 ⁻¹¹ N·m ² ·kg ⁻²
Radius of the Earth <i>Radius van die Aarde</i>	R _E	6,38 x 10 ⁶ m
Mass of the Earth <i>Massa van die Aarde</i>	M _E	5,98 x 10 ²⁴ kg
Speed of light in a vacuum <i>Spoed van lig in 'n vakuum</i>	c	3 x 10 ⁸ m·s ⁻¹
Planck's constant <i>Planck se konstante</i>	h	6,63 x 10 ⁻³⁴ J·s
Coulomb's constant <i>Coulomb se konstante</i>	k	9 x 10 ⁹ N·m ² ·C ⁻²
Charge on electron <i>Lading op elektron</i>	e	1,6 x 10 ⁻¹⁹ C
Electron mass <i>Elektronmassa</i>	m _e	9,11 x 10 ⁻³¹ kg



TABLE 2: FORMULAE/TABEL 2: FORMULES**MOTION/BEWEGING**

$v_f = v_i + a \Delta t$	$\Delta x = v_i \Delta t + \frac{1}{2} a \Delta t^2$ or/of $\Delta y = v_i \Delta t + \frac{1}{2} a \Delta t^2$
$v_f^2 = v_i^2 + 2a\Delta x$ or/of $v_f^2 = v_i^2 + 2a\Delta y$	$\Delta x = \left(\frac{v_i + v_f}{2} \right) \Delta t$ or/of $\Delta y = \left(\frac{v_i + v_f}{2} \right) \Delta t$

FORCE/KRAG

$F_{\text{net}} = ma$	$p = mv$
$f_s^{\text{max}} = \mu_s N$	$f_k = \mu_k N$
$F_{\text{net}} \Delta t = \Delta p$ $\Delta p = mv_f - mv_i$	$w = mg$
$F = G \frac{m_1 m_2}{d^2}$ or/of $F = G \frac{m_1 m_2}{r^2}$	$g = G \frac{M}{d^2}$ or/of $g = G \frac{M}{r^2}$

WORK, ENERGY AND POWER/ARBEID, ENERGIE EN DRYWING

$W = F \Delta x \cos \theta$	$U = mgh$ or/of $E_p = mgh$
$K = \frac{1}{2} mv^2$ or/of $E_k = \frac{1}{2} mv^2$	$W_{\text{net}} = \Delta K$ or/of $W_{\text{net}} = \Delta E_k$ $\Delta K = K_f - K_i$ or/of $\Delta E_k = E_{kf} - E_{ki}$
$W_{\text{nc}} = \Delta K + \Delta U$ or/of $W_{\text{nc}} = \Delta E_k + \Delta E_p$	$P = \frac{W}{\Delta t}$
$P_{\text{ave}} = F v_{\text{ave}}$ / $P_{\text{gemid}} = F v_{\text{gemid}}$	

WAVES, SOUND AND LIGHT/GOLWE, KLANK EN LIG

$v = f \lambda$	$T = \frac{1}{f}$
$f_L = \frac{v \pm v_L}{v \pm v_s} f_s$ / $f_L = \frac{v \pm v_L}{v \pm v_b} f_b$	$E = hf$ or/of $E = h \frac{c}{\lambda}$
$E = W_0 + E_{k(\text{max})}$ or/of $E = W_0 + K_{\text{max}}$ where/waar	
$E = hf$ and/en $W_0 = hf_0$ and/en $E_{k(\text{max})} = \frac{1}{2} mv_{\text{max}}^2$ or/of $K_{\text{max}} = \frac{1}{2} mv_{\text{max}}^2$	



ELECTROSTATICS/ELEKTROSTATIKA

$F = \frac{kQ_1Q_2}{r^2}$	$E = \frac{kQ}{r^2}$
$V = \frac{W}{q}$	$E = \frac{F}{q}$
$n = \frac{Q}{e}$ or/of $n = \frac{Q}{q_e}$	

ELECTRIC CIRCUITS/ELEKTRIESE STROOMBANE

$R = \frac{V}{I}$	emf (ε) = I(R + r) emk (ε) = I(R + r)
$R_s = R_1 + R_2 + \dots$ $\frac{1}{R_p} = \frac{1}{R_1} + \frac{1}{R_2} + \dots$	$q = I\Delta t$
$W = Vq$ $W = VI\Delta t$ $W = I^2R\Delta t$ $W = \frac{V^2\Delta t}{R}$	$P = \frac{W}{\Delta t}$ $P = VI$ $P = I^2R$ $P = \frac{V^2}{R}$

ALTERNATING CURRENT/WISSELSTROOM

$I_{rms} = \frac{I_{max}}{\sqrt{2}}$ / $I_{wgk} = \frac{I_{maks}}{\sqrt{2}}$	$P_{ave} = V_{rms} I_{rms}$ / $P_{gemid} = V_{wgk} I_{wgk}$
$V_{rms} = \frac{V_{max}}{\sqrt{2}}$ / $V_{wgk} = \frac{V_{maks}}{\sqrt{2}}$	$P_{ave} = I_{rms}^2 R$ / $P_{gemid} = I_{wgk}^2 R$
	$P_{ave} = \frac{V_{rms}^2}{R}$ / $P_{gemid} = \frac{V_{wgk}^2}{R}$

